

Doc 9157
AN/901



Aerodrome Design Manual

Part 4
Visual Aids

Approved by the Secretary General
and published under his authority

Fourth Edition — 2004

International Civil Aviation Organization

Published in separate English, French, Russian and Spanish editions by the International Civil Aviation Organization. All correspondence, except orders and subscriptions, should be addressed to the Secretary General.

Orders should be sent to one of the following addresses, together with the appropriate remittance in U.S. dollars or in the currency of the country in which the order is placed. Customers are encouraged to use credit cards (MasterCard, Visa or American Express) to avoid delivery delays. Information on payment by credit card and by other methods is available in the Ordering Information Section of the *Catalogue of ICAO Publications*.

International Civil Aviation Organization. Attention: Customer Services Unit, 999 University Street, Montréal, Quebec, Canada H3C 5H7
Telephone: +1 514-954-8022; Facsimile: +1 514-954-6769; Sitatex: YULCAYA; E-mail: sales@icao.int;
World Wide Web: <http://www.icao.int>

Botswana. Kags and Tsar Investments (PTY) Ltd., Private Bag 254/525, Gaborone
Telephone: +267 390 4384/8; Facsimile: +267 395 0004; E-mail: ops@kagsandtsar.co.bw

Cameroun. KnowHow, 1, Rue de la Chambre de Commerce-Bonanjou, B.P. 4676, Douala / Telephone: +237 343 98 42; Facsimile: +237 343 89 25;
E-mail: knowhow_doc@yahoo.fr

China. Glory Master International Limited, Room 434B, Hongshen Trade Centre, 428 Dong Fang Road, Pudong, Shanghai 200120
Telephone: +86 137 0177 4638; Facsimile: +86 21 5888 1629; E-mail: glorymaster@online.sh.cn

Egypt. ICAO Regional Director, Middle East Office, Egyptian Civil Aviation Complex, Cairo Airport Road, Heliopolis, Cairo 11776
Telephone: +20 2 267 4840; Facsimile: +20 2 267 4843; Sitatex: CAICAYA; E-mail: icaomid@cairo.icao.int

Germany. UNO-Verlag GmbH, August-Bebel-Allee 6, 53175 Bonn / Telephone: +49 0 228-94 90 2-0; Facsimile: +49 0 228-94 90 2-22;
E-mail: info@uno-verlag.de; World Wide Web: <http://www.uno-verlag.de>

India. Oxford Book and Stationery Co., 57, Medha Apartments, Mayur Vihar, Phase-1, New Delhi – 110 091
Telephone: +91 11 65659897; Facsimile: +91 11 22743532

India. Sterling Book House – SBH, 181, Dr. D. N. Road, Fort, Mumbai 400 001
Telephone: +91 22 2261 2521, 2265 9599; Facsimile: +91 22 2262 3551; E-mail: sbh@vsnl.com

India. The English Book Store, 17-L Connaught Circus, New Delhi 110001
Telephone: +91 11 2341-7936, 2341-7126; Facsimile: +91 11 2341-7731; E-mail: ebs@vsnl.com

Japan. Japan Civil Aviation Promotion Foundation, 15-12, 1-chome, Toranomom, Minato-Ku, Tokyo
Telephone: +81 3 3503-2686; Facsimile: +81 3 3503-2689

Kenya. ICAO Regional Director, Eastern and Southern African Office, United Nations Accommodation, P.O. Box 46294, Nairobi
Telephone: +254 20 7622 395; Facsimile: +254 20 7623 028; Sitatex: NBOCAYA; E-mail: icao@icao.unon.org

Mexico. Director Regional de la OACI, Oficina Norteamérica, Centroamérica y Caribe, Av. Presidente Masaryk No. 29, 3^{er} Piso, Col. Chapultepec Morales, C.P. 11570, México D.F. / Teléfono: +52 55 52 50 32 11; Facsimile: +52 55 52 03 27 57;
Correo-e: icao_nacc@mexico.icao.int

Nigeria. Landover Company, P.O. Box 3165, Ikeja, Lagos
Telephone: +234 1 4979780; Facsimile: +234 1 4979788; Sitatex: LOSLORK; E-mail: aviation@landovercompany.com

Peru. Director Regional de la OACI, Oficina Sudamérica, Av. Víctor Andrés Belaúnde No. 147, San Isidro, Lima (Centro Empresarial Real, Vía Principal No. 102, Edificio Real 4, Floor 4)
Teléfono: +51 1 611 8686; Facsimile: +51 1 611 8689; Correo-e: mail@lima.icao.int

Russian Federation. Aviaizdat, 48, Ivan Franko Street, Moscow 121351 / Telephone: +7 095 417-0405; Facsimile: +7 095 417-0254

Senegal. Directeur régional de l'OACI, Bureau Afrique occidentale et centrale, Boîte postale 2356, Dakar
Téléphone: +221 839 9393; Fax: +221 823 6926; Sitatex: DKRCAYA; Courriel: icaodkr@icao.sn

Slovakia. Letové prevádzkové služby Slovenskej Republiky, Štátny podnik, 823 07 Bratislava 21
Telephone: +421 2 4857 1111; Facsimile: +421 2 4857 2105; E-mail: sa.icao@Ips.sk

South Africa. Avex Air Training (Pty) Ltd., Private Bag X102, Halfway House, 1685, Johannesburg
Telephone: +27 11 315-0003/4; Facsimile: +27 11 805-3649; E-mail: avex@iafrica.com

Spain. A.E.N.A. — Aeropuertos Españoles y Navegación Aérea, Calle Juan Ignacio Luca de Tena, 14, Planta Tercera, Despacho 3. 11, 28027 Madrid / Teléfono: +34 91 321-3148; Facsimile: +34 91 321-3157; Correo-e: ssc.ventasoci@aena.es

Switzerland. Adeco-Editions van Diermen, Attn: Mr. Martin Richard Van Diermen, Chemin du Lacuez 41, CH-1807 Blonay
Telephone: +41 021 943 2673; Facsimile: +41 021 943 3605; E-mail: mvandiermen@adeco.org

Thailand. ICAO Regional Director, Asia and Pacific Office, P.O. Box 11, Samyae Ladprao, Bangkok 10901
Telephone: +66 2 537 8189; Facsimile: +66 2 537 8199; Sitatex: BKKCAYA; E-mail: icao_apac@bangkok.icao.int

United Kingdom. Airplan Flight Equipment Ltd. (AFE), 1a Ringway Trading Estate, Shadowmoss Road, Manchester M22 5LH
Telephone: +44 161 499 0023; Facsimile: +44 161 499 0298; E-mail: enquiries@afeonline.com; World Wide Web: <http://www.afeonline.com>

Catalogue of ICAO Publications

Issued annually, the Catalogue lists all publications currently available. Supplements to the Catalogue announce new publications, amendments, supplements, etc. The Catalogue is accessible on the ICAO website at www.icao.int.

Doc 9157
AN/901



Aerodrome Design Manual

Part 4
Visual Aids

Approved by the Secretary General
and published under his authority

Fourth Edition — 2004

International Civil Aviation Organization

FOREWORD

Proper design and installation of visual aids are prerequisites for the safety and regularity of civil aviation. Accordingly, this manual includes guidance on the characteristics of visual aids used at airports.

The material included herein is closely associated with the specifications contained in Annex 14 — *Aerodromes*, Volume I — *Aerodrome Design and Operations*. The main purpose of the manual is to assist States in the implementation of these specifications and thereby help to ensure their uniform application.

This fourth edition incorporates changes and additions resulting from an overall review made by the Secretariat. The more important of these changes/additions are as follows:

- a) the deletion of VASIS and 3-BAR VASIS as standard visual approach slope indicator systems (Chapter 8);
- b) updated material on surface movement guidance and control systems (Chapter 10);
- c) updated guidance material on signs (Chapter 11);
- d) updated material on visual docking guidance systems (Chapter 12);
- e) guidance on marking and lighting of obstacles (Chapter 14);
- f) updated material on frangibility of visual aids (Chapter 15);
- g) guidance on the application of approach and runway lighting systems (Chapter 16);
- h) guidance on maintenance of lighting performance (Chapter 17); and
- i) material on measurement of intensity for steady burning and flashing lights (Chapter 18).

It is intended that the manual be kept up to date. Future editions will be improved based on the work of the Visual Aids Panel of ICAO as well as on experience gained and comments and suggestions received from users of this manual. Readers are therefore invited to give their views, comments and suggestions on this edition. These should be directed to the Secretary General of ICAO.

Table of Contents

	<i>Page</i>		<i>Page</i>
Chapter 1. Functional requirements of visual ground aids	1-1	Chapter 7. Circling guidance lights	7-1
1.1 Introduction	1-1	7.1 Introduction	7-1
1.2 Operational factors	1-1	7.2 Lighting requirements	7-1
1.3 Operating requirements	1-8		
1.4 How visual aids and visual cues serve pilots	1-10	Chapter 8. Visual approach slope indicator systems	8-1
1.5 Designation of high-, medium- and low-intensity lighting	1-22	8.1 General	8-1
Chapter 2. Markings and markers	2-1	8.2 T-VASIS	8-2
2.1 General	2-1	8.3 PAPI.....	8-12
2.2 Additional marking of paved shoulders ...	2-1		
2.3 Apron markings	2-1	Chapter 9. Runway and taxiway lighting	9-1
2.4 Taxiway edge markers.....	2-11	9.1 Inset lights	9-1
Chapter 3. Signal area and panels	3-1	9.2 Taxiway edge lights — “sea of blue” effect	9-2
3.1 General.....	3-1	9.3 Exit taxiway lighting	9-2
3.2 Design	3-1		
Chapter 4. Light characteristics for and taxiways used in low visibility conditions	4-1	Chapter 10. Surface movement guidance and control systems	10-1
4.1 Factors determining required light distribution	4-1	10.1 General	10-1
4.2 Flight path envelopes	4-1	10.2 Operational requirements	10-1
4.3 Operational requirements and assumptions	4-1	10.3 The role of visual aids	10-2
4.4 Operating procedures in RVR less than 350 m	4-2	10.4 Visual aid components of an SMGC system	10-3
4.5 Analysis of lighting design	4-2	10.5 Implementation issues	10-6
4.6 Lighting specifications	4-3		
Chapter 5. Light intensity settings	5-1	Chapter 11. Signs	11-1
Chapter 6. Runway lead-in lighting system	6-1	11.1 General	11-1
		11.2 Design	11-1
		11.3 Variable message signs	11-2
		11.4 Mandatory instruction signs	11-3
		11.5 Information signs	11-5
		11.6 Sign location	11-7
		11.7 Sign evaluation	11-7

	<i>Page</i>		<i>Page</i>
Chapter 12. Visual parking and docking guidance systems	12-1	16.4 Lighting for precision approach runways — Category I, II and III.	16-2
12.1 Introduction	12-1	16.5 Pattern variations and additions	16-4
12.2 Aircraft stand manoeuvring guidance lights	12-1	16.6 Reduction of lighting patterns	16-4
12.3 Visual docking guidance system	12-1	16.7 Selection of lighting patterns	16-5
 Chapter 13. Apron floodlighting	 13-1	 Chapter 17. Maintenance of lighting performance	 17-1
13.1 Introduction	13-1	17.1 General	17-1
13.2 Functions	13-1	17.2 The maintenance environment	17-1
13.3 Performance requirements	13-1	17.3 Maintenance requirements	17-1
13.4 Design criteria	13-2	17.4 Monitoring of light output	17-2
 Chapter 14. Marking and lighting of obstacles	 14-1	17.5 Demonstration of conformance	17-5
14.1 General	14-1	 Chapter 18. Measurement of the light intensity of steady burning and flashing lights	 18-1
14.2 Conspicuity enhancement techniques	14-2	18.1 Introduction	18-1
14.3 Marking	14-2	18.2 Criteria	18-1
14.4 Lighting characteristics	14-3	18.3 Flashing lights	18-4
14.5 Location of lighting	14-6	 Appendix 1. The operational requirements of visual nose-in docking guidance systems	 A1-1
14.6 Installation of high-intensity obstacle lighting	14-8	 Appendix 2. The operational requirements of visual parking guidance systems	 A2-1
14.7 Monitoring and maintenance	14-11	 Appendix 3. Selection, application and removal of paints	 A3-1
 Chapter 15. Frangibility of visual aids	 15-1	 Appendix 4. Procedures for developing light intensities for day conditions	 A4-1
15.1 What is frangibility?	15-1	 Appendix 5. Method used to develop the graphical presentations in Figures 5-1 to 5-3	 A5-1
15.2 Obstacle to be made frangible	15-1	 Appendix 6. Eye-to-wheel and eye-to-aerial heights of aeroplanes	 A6-1
15.3 Visual aids	15-2		
 Chapter 16. Application of approach and runway lighting systems	 16-1		
16.1 General	16-1		
16.2 Lighting system design	16-1		
16.3 Lighting for non-instrument and non-precision approach runways	16-2		

Chapter 1

Functional Requirements of Visual Ground Aids

1.1 INTRODUCTION

The purpose of this chapter is to provide engineering personnel with a general appreciation of the task of the pilot-in-command in relation to the use of and reliance upon visual aids and visual cues in approaching, landing and operating on the airport surface. The information provided herein is for illustrative purposes only and is not necessarily meant to imply ICAO approval or endorsement of the operational practices and procedures described. For currently approved detailed operational procedures and practices, reference should be made to pertinent operational and training documents.

1.2 OPERATIONAL FACTORS

The pilot's problem

1.2.1 Human beings are two-dimensional animals. From the moment we first start to crawl, we interpret visual cues and use our sense of balance to travel over the surface of the earth. This long and gradual learning process continues as we later take charge of various types of mechanical transport on land or water, by which time we have years of accumulated experience on which to draw. As soon as we take to the air we have a third dimension to cope with, and this means that all our years of experience in solving two-dimensional problems are no longer sufficient.

1.2.2 There are two ways of controlling an aircraft in flight — either manually or by means of the automatic pilot. The pilot can effect manual control either by reference to the instrument panel or by reference to visual cues in the outside world. The latter method presupposes adequate visibility and a clearly defined horizon, which may be the actual horizon or an apparent horizon perceived from gradients in the texture or the detail on the earth's surface.

1.2.3 Some of the most difficult tasks when flying an aircraft visually are judging the approach to a runway and the subsequent landing manoeuvre. During the approach,

not only must the speed be carefully controlled, but continuous simultaneous corrections in all three dimensions are necessary in order to follow the correct flight path. For a straight-in approach, this may be defined as the intersection of two planes at right angles, the vertical plane containing the extended centre line of the runway and the other plane containing the approach slope.

1.2.4 Maintaining an accurate approach slope solely by reference to a view of the outside world is often difficult. The task difficulty varies for each aircraft. Propeller-driven aircraft have an almost instantaneous reaction to an increase in power; the faster airflow over the wings from the speeded-up propellers provide an immediate increase in lift. The jet engine is not only slower to respond to an advance in throttle setting, but also has no direct effect on the airflow over the wing. Not until the whole mass of the aircraft has been accelerated following an increase in thrust will an increase in lift result. The conditions where a visual approach slope indicator system shall be provided are listed in Annex 14, Volume I, 5.3.5.1.

1.2.5 It is essential that aircraft cross the runway threshold with a safe margin of both height and speed. In order to effect a smooth touchdown, both the speed and the rate of descent must be simultaneously reduced in the manoeuvre known as the landing flare, so that the wheels touch the runway just prior to or as the wing stalls.

1.2.6 After touchdown, the pilot has a continuing requirement for directional guidance to keep the aircraft along or near the middle of the runway (at touchdown speeds generally within a range of 100 kt to 160 kt or 185 km/h to 296 km/h). The pilot also needs information from which an assessment can be made of the length of runway remaining and, once the aircraft has slowed sufficiently, advance warning of a suitable runway exit, its width clearly delineated where taxiway centre line lighting is not provided.

1.2.7 Once clear of the runway, the pilot has to taxi the decidedly unwieldy vehicle along an often complicated

layout of taxiways to the correct parking/docking position on an apron which may well be congested. The pilot must be given a clear indication of the route to follow and be prevented from crossing any runway in use, as well as being protected from conflicting taxiing aircraft and vehicles.

1.2.8 If we examine the case of long-bodied jets, the taxiing pilot has to control one of the largest, heaviest and most inefficiently powered tricycles ever made. The pilot is seated at least 6 m above the ground, and the nearest point ahead which can be seen is more than 12 m. The steerable nose wheel is several metres behind the pilot's seat on the flight deck (this brings its own special problems when negotiating a curve), while the main wheel bogies are at least 27 m behind. There is, of course, no "direct drive" to these wheels, and thrust from the jet engines, notoriously inefficient at low forward speeds, must be used. As with many modern swept-wing jets (irrespective of size), it is often impossible for the pilot to see the wing tips from the flight deck.

1.2.9 The manner in which all the varied operational requirements outlined in the preceding paragraphs are satisfied by visual aids is described in detail in Section 1.4.

The four Cs

1.2.10 There are four main elements that comprise the character of the complete airport lighting system as it has evolved from research and development programmes and practical field experience over a long period of time. These elements may be conveniently referred to as the "four Cs" — configuration, colour, candelas and coverage. Both configuration and colour provide information essential to dynamic three-dimensional orientation. Configuration provides guidance information, and colour informs the pilot of the aircraft's location within the system. Candelas and coverage refer to light characteristics essential to the proper functioning of configuration and colour. A competent pilot will be intimately familiar with system configuration and colour and will also be aware of candela changes which increase or decrease light output. These four elements apply to all airport lighting systems, in greatly varying degrees, depending on such factors as the size of the airport and the visibility conditions in which operations are envisaged, and are reviewed in the paragraphs which follow.

Configuration

1.2.11 This concerns the location of components and spacing of lights and markings within the system. Lights are arranged in both longitudinal and transverse rows with

respect to the runway axis, whereas painted runway markings are aligned only longitudinally with the runway axis. (The foreshortening effect of viewing transverse markings at approach angles makes painted transverse markings impractical.)

1.2.12 Light spacing varies primarily with regard to whether a longitudinal or transverse array is involved. It is apparent that a pilot's perspective of visual aid systems causes widely spaced lights in a longitudinal row to assume a "linear effect". On the other hand, close spacings are required to achieve a "linear effect" with lights in a transverse row. Another factor influencing light spacing is the visibility under which the system is to be used. When operations are conducted in lower visibilities, closer spacings are required, especially in longitudinal rows, to provide adequate visual cues within the reduced visual range.

1.2.13 Locating and installing lights for the runway edge, threshold and runway end was never a problem since the very words themselves denote location. Installing threshold lights is somewhat complicated, however, when the threshold is displaced. Development of semi-flush light fittings makes it possible to locate runway lighting in a standard configuration within runway pavement. Spacing of lights associated with runway edges has changed very little since runways were first lighted. Primary visual guidance in low visibilities comes from the centre line and touchdown zone lighting systems.

1.2.14 While development of runway lighting is fairly uncomplicated, approach light research and development has resulted in major differences in both location and spacing for systems in various States. In contemplating operations for precision approach Category II runways, it was agreed that a standard configuration was needed for at least the 300 m of the system before the threshold. A cooperative programme by ICAO States achieved this objective in the 1960s.

Colour

1.2.15 The function of coloured light signals is to help identify the different lighting systems of the aerodrome, to convey instructions or information and to increase conspicuity. Thus, for example, runway edge lights are white, and taxiway edge lights are blue; red obstacle lights are more readily seen against a background of white lights than are lights of other colours, their red colour also indicating a hazard.

1.2.16 Although many colours can be recognized when the coloured surfaces are large enough to be seen as an area,

only four distinct coloured light signals can be recognized when the lights are seen alone and as “point” sources.

1.2.17 With proper selection of colour specifications, red, white or yellow, green and blue can generally be recognized. White and yellow can be differentiated only when:

- a) the lights of the two colours are shown simultaneously in adjacent parts of the same signal system; or
- b) the white and yellow are shown as successive phases of the same signal; or
- c) the signal has appreciable size so that it does not appear as a point source.

Because of the limitation of recognizable colours, the colours have more than one meaning, and the location and configuration of coloured lights provide the required differentiation. For example, green is used for threshold lights, for taxiway centre line lights and in traffic control lights.

1.2.18 Coloured lights can be obtained by using an incandescent tungsten source in combination with the appropriate light filter. The filter may be dyed glass, or it may consist of a film deposit on a glass substrate. This filter may be either an additional component in a light fitting which would otherwise provide a white signal, or an integral part of the optical system of the fitting. In either case, the action of the filter consists of the removal of light of unwanted wavelengths, not the addition of light of the desired wavelength. In addition, some light of the desired wavelength is removed. Thus, the intensity of the coloured fitting is less than it would be if the fitting were designed to emit white light. The intensities of coloured signals are a percentage of the intensity possible with a white signal, i.e. approximately 40 per cent for yellow, 20 per cent for red and green and 2 per cent for blue.

1.2.19 However, it should be noted that since the illuminance threshold for red light is about half the illuminance threshold for white light, the effective visual range of a red light produced by adding a red filter to a white fitting is greater than the percentage given above indicates.

Candelas

1.2.20 It is the illumination at the observer’s eye, produced by a light, which will determine if the light will

be seen. The illumination produced at a distance V by a light source having an intensity I , measured in candelas (cd), in an atmosphere having a transmissivity (transmittance per unit distance) T is given by Allard’s law:

$$E = \frac{IT^V}{V^2}$$

When the illuminance is equal to E_c , the minimum perceptible illuminance, the light can just be seen and V is the visual range of the light. Values for the minimum perceptible illuminance for use in determining the visual range given in Annex 3, Attachment C, are:

	Illumination threshold	
	lux	kilometre candles
Night	8×10^{-7}	0.8
Intermediate value	10^{-5}	10
Normal day	10^{-4}	100
Bright day (sunlit fog)	10^{-3}	1 000

1.2.21 The relation between transmissivity T , distance V , and the ratio of intensity to illuminance, I/E , is shown in Figure 1-1. Intensities of lights used in aerodrome lighting range from about 10 cd to 200 000 cd. The transmissivity of the atmosphere varies over an extreme range, from more than 0.95 in very clear weather to less than 10^{-50} per km in dense fog.

1.2.22 As is evident from Figure 1-1, when the atmosphere is clear, a light of relatively low intensity can be seen a long distance. Consider, for example, night-time conditions in which the transmissivity is 0.90 per km. Then, for a light having an intensity of 80 cd, I/E would be 80/.8 or 100, and the visual range would be about 7 km. However, in fog, the law of diminishing returns takes effect at relatively short distances. For example, if the transmittance was 10^{-20} per km (thick fog), a light with an intensity of 80 cd could be seen at about 0.17 km, and a light having an intensity of 80 000 cd could be seen only at about 0.3 km. Consequently, it is not possible to obtain sufficient guidance from runway edge lights in Category II and III operations by increasing the intensities of lights which were designed for use in clearer weather. Changes in configuration and decreases in spacing are required. Touchdown zone and closely spaced centre line lights are added to the runway lighting system in order to decrease the distances at which lights are required to be seen, and hence improve the cues.

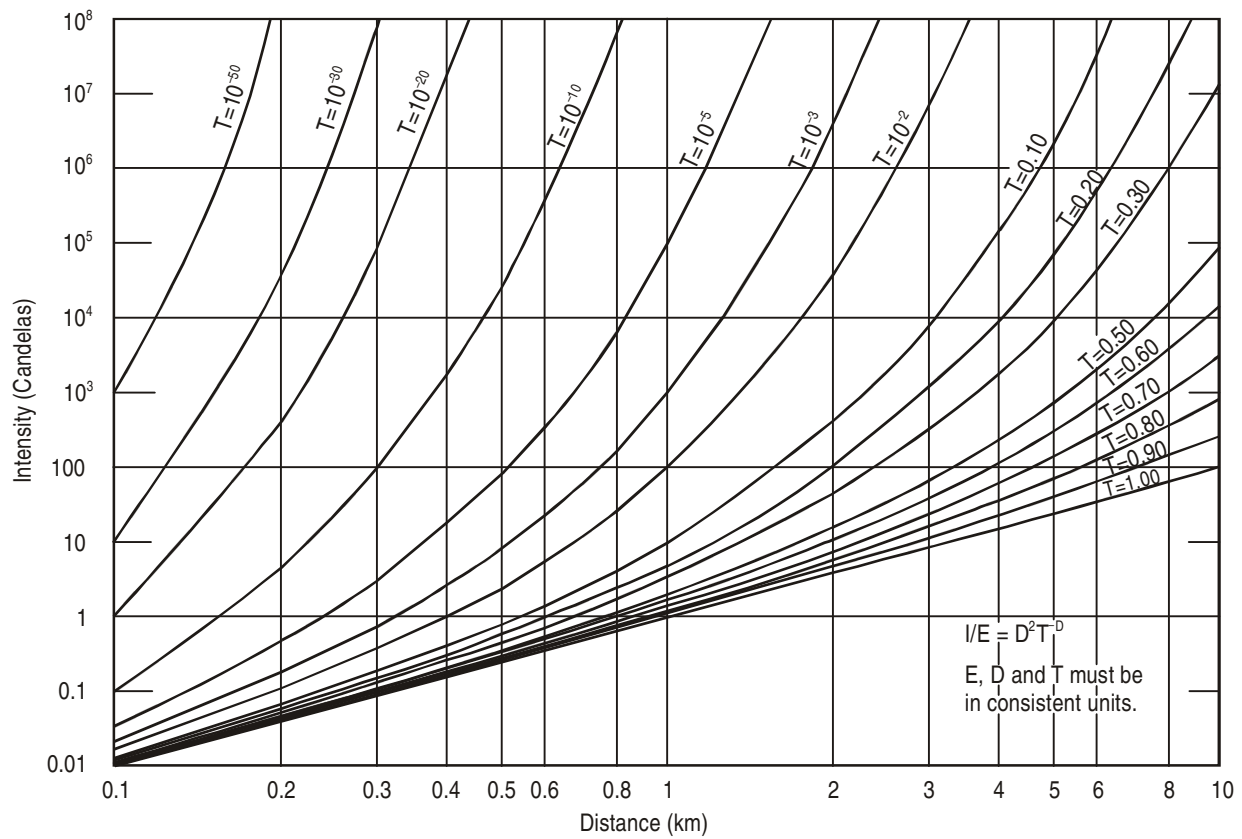

Figure 1-1. The intensity required to produce unit illuminance as a function of distance for several atmospheric transmissivities

1.2.23 Another effect of the atmosphere which must be considered is the marked difference the atmospheric transmittance makes in the appearance of lights, e.g. an 80 000 cd light which could just be seen at 0.3 km when the transmissivity was 10^{-20} per km would produce an illuminance at the observer's eye of one million times that required to be just visible in perfectly clear air. Dimming is therefore required. However, even if this light were dimmed to 0.1 per cent of its full intensity, it would still be much more intense than desired. Consequently, although dimming of high-intensity and runway lights is required, it cannot completely compensate for the effects of changes in atmospheric transmittance.

Coverage

1.2.24 Early aeronautical ground lights consisted of bare lamps or bare lamps with clear glass covers. Emitted

light had essentially the same intensity in all directions. As the need for higher intensities developed, lights with reflectors, lenses or prisms were put into service. By redirecting light emission from unnecessary directions toward directions where needed, the intensity in desired directions was increased without increasing power consumed. In addition, annoying glare from nearby lights was reduced by redirecting some of the light emitted in directions from which it is viewed only at very short distances to directions from which it is viewed at greater distances at longer visibilities. The narrower the beam produced by the optical system, the higher the intensity of the light within the beam for a given power consumption.

1.2.25 In theory it is possible to design an optical system for a light so that, for any fixed line of approach and for any given atmospheric transmissivity, the peak intensity of the light beam is directed at the point at which the light will first be seen. As the distance between the aircraft and

the light decreases, the intensity in the direction of the aircraft decreases, so that the brightness of the light is constant. (Paths which go directly toward the light are excluded.) Thus, it is possible to design a beacon so that, for any selected atmospheric transmissivity, the flashes will have constant brightness when viewed from an aircraft flying toward the beacon at a fixed height above it. Such a design minimizes the amount of power required to obtain the desired visual range. However, aircraft do not fly only one path in one visibility condition. Hence, it is necessary to design the beam patterns of aeronautical ground lights to cover a range of paths and of atmospheric transmissivities.

1.2.26 These principles have been observed in the determination of the beam spreads of the lights specified in Annex 14, Volume I, Appendix 2. These were based on simple geometric considerations using a homogeneous fog structure.

The human element in ground visual aid use

1.2.27 There are numerous factors that determine how effectively pilots react to visual aids — in sensing, understanding and acting on elements of guidance and information viewed during an approach. While it would not be possible to review the cause and effect of all of the problems, the following are those associated with system design and visual cues within the environment and the possibility of pilot error arising during the approach and landing operation.

System standardization

1.2.28 The pilot always views the approach and runway lighting system in perspective, never in plan, and only in the better meteorological conditions will the complete system be in view. The pilot, while proceeding along the approach path, has to interpret the guidance provided by a “moving visual segment” of lights which will continuously move down the windshield. The length of this segment will vary according to aircraft height and the slant visual range from the cockpit. (See Figure 1-2.) The amount of information that can be absorbed from a comparatively short length of the approach light pattern when viewed at high speed in low visibility is strictly limited. Since only a few seconds of time are available to see and react to visual aids in the lower visibilities, simplicity of pattern, in addition to standardization, is extremely important.

Individual differences

1.2.29 Visual acuity and sensitivity to glare vary from pilot to pilot and are partly determined by age, fatigue and adaptation to prevailing light levels. Moreover, a given pilot’s abilities, reactions and responses will vary from day to day. Also, the visual guidance system must be able to accommodate variations in pilot proficiency.

Mechanics of seeing

1.2.30 In order for guidance to always be presented to the pilot in the best possible manner, two important factors must be considered. First, it is essential that the intensity setting is carefully matched to ambient conditions. Second, the intensities of the various individual sections comprising the whole system must also be carefully matched, particularly where colour is used. These two factors ensure that the pilot neither misses a vital cue, such as the green threshold lights, because the signal is too weak, nor is dazzled because certain lights are too bright for the prevailing conditions.

1.2.31 There are two reasons why approach and runway lighting systems are provided with patterns that emphasize the centre line. One obvious reason is that the ideal landing position is along the centre of the runway. The other is that the fovea of the eye, the region of sharp vision, is only about 1.5 degrees in width.

1.2.32 Studies have shown that the average time required for a pilot to switch from outside visual cues to instruments and back to outside cues is about 2.5 seconds. Since high performance aircraft will travel at least 150 m in this time period, it is apparent that in so far as possible the visual aids should provide the utmost in guidance and information, enabling the pilot to proceed without the necessity of cross-checking the instruments. Other crew members, or cockpit synthetic voice alerting systems are used to announce critical instrument-derived information, a procedure enhancing the safety of operations.

Visual workload

1.2.33 The data processing capability of the pilot is extensive if certain conditions are met, particularly when the situation unfolds as expected and succeeding cues confirm what has gone before. In this case, the pilot can attend to a rapidly evolving pattern of data, retain the ability to assess the situation, and execute a series of appropriate responses finely adjusted in time and degree. The pilot’s capacity to process information may break

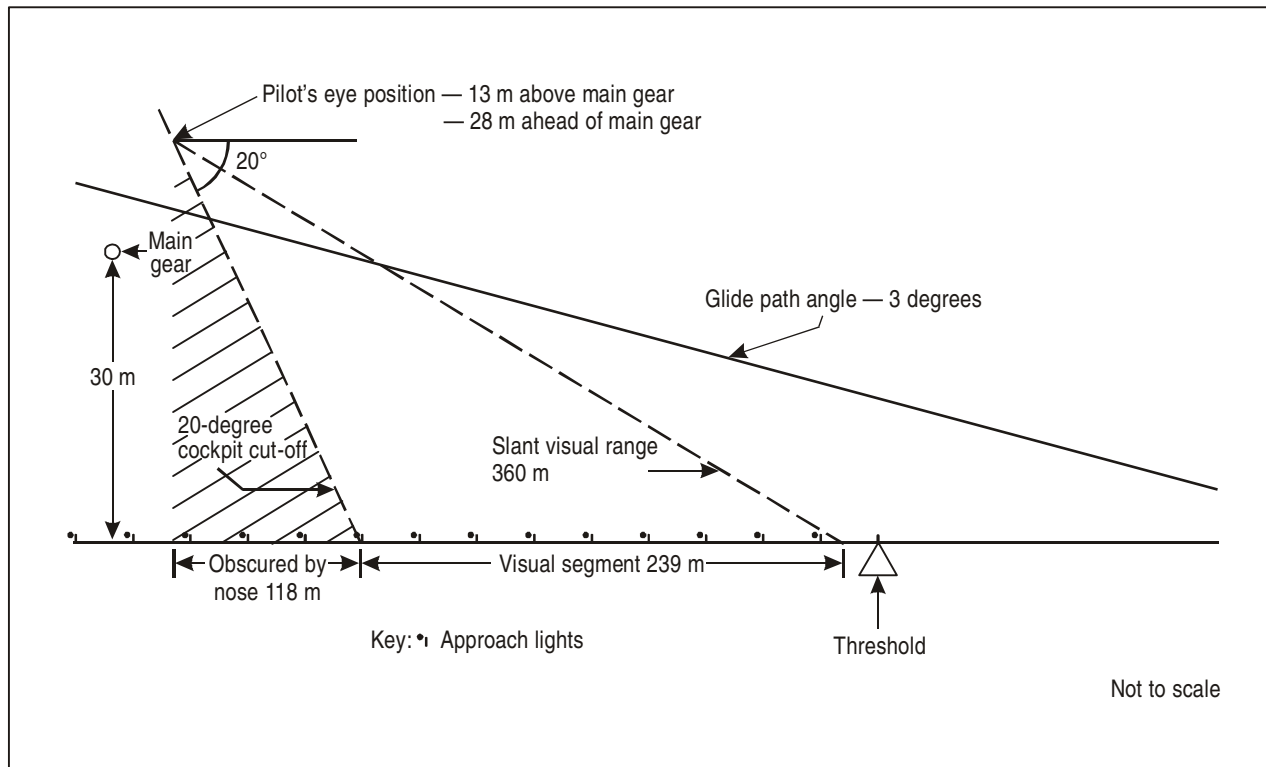

Note.— The threshold lights are just beyond the pilot's visual range.

Figure 1-2. Visual segment from a large-bodied jet aircraft

down where input data do not agree with expectations and are ambiguous or transitory. In this situation, the pilot may be induced to continue the operation when conditions actually call for a missed approach.

1.2.34 The above considerations suggest that it is extremely important to ensure that the visual guidance functions as a system. Component elements must be in balance with regard to intensity and spacing, ensuring that the pilot sees a pattern which is recognizable as the expected standard system, rather than a disorderly collection of uncoordinated elements. Visual workload is best moderated by standardization, balance and integrity of elements. A system with many missing lights can break the pattern from the pilot's eye position, restricted as that position is by cockpit cut-off angles and possibly by patchy fog or other conditions. It is possible, when transitioning from the instrument panel, to become momentarily disorientated in a poorly maintained or visually unbalanced system.

Visual problems during approach to landing

1.2.35 Pilots are faced with complex visual problems when approaching any runway which lacks visual or non-visual guidance along the correct approach slope angle. Some of these problems are commonly classified as visual illusions, but the main problem, rather than false or misleading cues, is the actual absence or scarcity of visual cues upon which to base height/distance judgements. All runways are liable to have this type of problem associated with them to some extent. Any runway that is normally served by a non-visual aid can present these problems during any period of unserviceability of that aid. Similar problems apply to aircraft that are not equipped with non-visual aid systems. In reviewing visual approach problems below, an assumption has been made that visual/non-visual aids are not available (or not in use if available) to guide the pilot along the approach slope to the runway.

Terrain-related problems

1.2.36 By day, height/distance judgement problems occur when approaching runways over large bodies of water, featureless terrain (including snow-covered terrain) and terrain that is depressed below the horizontal plane of the runway in the form of deep valleys, steep slopes, etc. This is due to the absence or reduction of normal visual cues that assist height/distance judgements. For this same reason, height/distance judgements are difficult on dark nights where there is an absence of sufficient extraneous lighting defining a ground plane in and around the approach area. However, extraneous lighting within deep valleys, along steep slopes, etc., can complicate the decision-making process because pilots may think they are too high when on the correct approach slope to the runway. Compensatory manoeuvring based on inadequate information is likely to place aircraft on an incorrect approach slope angle to the runway.

1.2.37 Take-offs over large bodies of water or barren land during haze conditions, even during daylight, can prove dangerous for pilots unable to operate aircraft with reference to flight instruments. This problem is accentuated for such pilots if visual cues are not visible following take-off without requiring them to turn their heads over large angles to establish ground visual reference. Inclining the head when the aircraft is turning causes disorientation, known as vertigo, and is often accompanied by nausea. Flight instrument discipline is necessary to overcome vertigo; thus, if pilots are not instrument-qualified, hazardous consequences may develop.

1.2.38 Experienced pilots carry an “ideal” perspective image of the runway in their minds; consequently, runways sloping upward will tend to cause pilots to approach below the normal approach slope angle, and runways sloping downward will tend to cause pilots to approach above the normal approach slope angle. Because the average longitudinal slope of a runway should not exceed 2 per cent (1 per cent where the code number is 3 or 4), the error introduced would not normally create a serious problem. It can be seen, however, that conditions can combine to lessen or increase the total effect. For example, an approach to an upslope runway from over a deep valley would increase the tendency for pilots to approach below the normal approach slope angle to the runway.

1.2.39 Pilots unfamiliar with flying techniques associated with mountainous terrain may initiate lower-than-normal approach angles to runways when landing toward mountain ranges. This is due to the apparent horizon being above the true horizon, causing erroneous judgement as to

the correct relationship of the aiming point on the runway below the true horizon. If approaching over unlighted terrain on a dark night, the danger of undershooting the runway is increased.

Approach and runway lighting-related problems

1.2.40 Because bright lights appear nearer than less bright lights, maintenance of a reasonably balanced intensity for approach and runway lighting plays an important role in height/distance judgements during approach. In considering the problems associated with illusory perception, this factor is most important when visibility permits pilots to view both the approach and runway lighting systems during approach. In low visibility conditions, the various lighting patterns must be designed to provide continuity in the amount of information available to the pilot as the approach and landing proceeds.

1.2.41 Care should be taken to ensure that both sides of runway lighting afford a good balance. One side of a runway can become dimmer than the other side when electrical earth faults occur on one side or when snowploughing or snow blowing operations (or crosswinds) deploy snow along one of the runway edges.

1.2.42 It is desirable that pilots operate aircraft to runways having uniform spacings between rows of edge, touchdown zone and centre line lights and between individual lights within the system.

1.2.43 Operating into a shallow ground fog can be difficult because the approach and runway lighting patterns, which are visible through the fog as the approach descent is conducted, shorten rapidly or disappear entirely when the aircraft approaches and enters the top of the fog layer. In shallow fog, lighting cues are lost at low heights and pilots flying visually during the rapid transition from visual cues to loss of visual cues can receive a false impression of the aircraft climbing rather than descending. Reacting to the impression of aircraft climb, initiating an even steeper rate of descent from a low height without visual cues, or at best very limited visual cues, will cause the aircraft to impact terrain or the runway at a high rate of descent.

Runway dimension and contrast-related problems

1.2.44 Runways of varying widths and lengths can cause pilots to misjudge the approach slope angle because

wide/long runways will appear to be closer than will narrow/short runways. Pilots of large aircraft normally fly in and out of airports affording reasonably uniform perspective images. Pilots of small aircraft can operate into runways having greatly varying widths and lengths; thus, the small-aircraft pilot is normally the one most often experiencing an approach and landing problem related to runway configuration and will tend to operate at lower-than-normal approach slope angles into large runways. When applying visual aids, including markings to runways with abnormal dimensions, it is important to retain the normal spacing and dimensions specified for the aids. Any form of scaling will induce false estimates of range and size.

1.2.45 Operating aircraft toward the sun on clear days during an approach can involve extremely difficult visual problems. Under some conditions, glare interferes with vision to the extent that the runway is difficult to locate and when located, difficult to observe throughout the approach. In addition to the glare problem, runway contrast is changed (normally reduced) because the angle of the sunlight to the runway results in a “backlight” on the texture surrounding the pavement and also lowers the contrast of runway markings.

1.2.46 Contrast is an important aspect of visual acquisition. For instance, the highest visual acquisition rate is obtained when the contrast between the runway and the surrounding terrain is large.

Experience-related problems

1.2.47 Changes in experienced or accustomed visual cues can cause illusory perception problems. Pilots accustomed to flight over large trees can approach runways at lower than normal angles when flying over “scrubby” trees appearing to be of the same variety as the larger trees. Pilots who fly over basically flat land can experience difficulty in judging an approach to a runway located in rolling or mountainous terrain. Another example would be pilots, experienced in flight over heavily built-up areas, operating aircraft to runways located in open areas devoid of either constructed or natural large vertical objects.

Aircraft-related problems

1.2.48 Pilots will be able to make the best possible use of ground visual cues and aids when aircraft windshields are clean and free of precipitation. Rain-swept windshields cause ripples and blurs which distort vision.

Geometric patterns of ground visual aids can be destroyed, making it difficult, if not impossible, to properly interpret the design functioning of visual aids. Pilots should make the best use of rain-removal systems (windshield wipers, pneumatic rain removal, chemical rain repellents) when approaching to land in conditions of heavy rain.

1.3 OPERATING REQUIREMENTS

General

1.3.1 The operating requirements for visual aids vary according to the type of aircraft being flown, the meteorological conditions, the type of navigation aid used for the approach, the physical characteristics of the runway and taxiways, and whether or not landing information is available through radio communications.

Small airports

1.3.2 Airports designed for small single-engine and light-twin aircraft below 5 700 kg are often not provided with instrument approach aids or air traffic control facilities. Thus, at many small airports, ground visual aids must satisfy all of the operating requirements of pilots. Some of these airports may not be provided with paved runway surfaces — a situation which adds to the problem of providing pilots with adequate visual aids.

1.3.3 The operating requirements are:

- a) airport location;
- b) airport identification;
- c) landing information:
 - 1) wind direction and speed;
 - 2) runway designation;
 - 3) runway status — closed or usable;
 - 4) runway designation;
- d) circling guidance;
- e) final approach guidance to touchdown:

- 1) runway edge and threshold delineation;
- 2) approach slope guidance;
- 3) aiming point guidance;
- 4) runway centre line delineation;

Note.— Runway centre line delineation is not feasible for unpaved runways. Such runways are normally used only in conditions of good visibility. Thus, centre line delineation is not as important as it is at airports where operations in low visibilities are authorized in conjunction with an instrument approach aid.

- f) roll-out guidance:
 - 1) runway centre line delineation (see note under e) 4));
 - 2) runway edge delineation;
 - 3) exit taxiway location;
 - 4) exit taxiway edge and centre line delineation;
 - 5) runway end indication;
- g) taxiing guidance:
 - 1) taxiway edge and/or centre line delineation;
 - 2) information signs to parking and servicing areas;
 - 3) mandatory instruction signs;
- h) departure information;

Note.— The information needed is the same as that listed in c) above; however, pilots normally obtain all such information prior to leaving the Operations Office without reference to visual aids.

- i) take-off guidance:
 - 1) runway centre line delineation (see note under e) 4));
 - 2) runway edge delineation;
 - 3) runway end indication.

Large airports

1.3.4 Large airports are normally provided with radio navigation aids and air traffic control facilities requiring radio communications. When used in visual meteorological conditions (VMC) without these aids, the requirements for ground visual aids are the same as those stated for small airports. In addition, large airports are provided with guidance systems to park aircraft on stands, as well as visual docking guidance systems at terminals equipped with passenger gangways (aerobridges). Effective apron illumination is needed to assist in parking aircraft to protect passengers moving to and from aircraft and to facilitate aircraft servicing activities.

1.3.5 Flights conducted in instrument meteorological conditions (IMC) require visual aids in addition to those listed above for small airports. The visual aids together with non-visual guidance and control functions provide a complete approach, landing and taxiing system. Similarly, ground movements and departures are supported by a combination of visual and non-visual aids. The following additional operating requirements are related to the relevant visibility conditions applied to the four categories of instrument runways (Annex 14, Volume I, 1.1 refers). For take-off operations there are additional considerations for runway edge and centre line lights (Annex 14, Volume 1, 5.3.9 and 5.3.12 refer). In some circumstances, these provisions may be the most demanding. For example, if precision guidance is not available on a particular runway, the take-off visibility limits may be the determining factor in the provision of lighting aids.

Non-precision approach runway

Final approach guidance to touchdown:

- Centre line alignment guidance for a distance of at least 420 m before the threshold.
- An indication of distance 300 m before the threshold.

Precision approach runway — Category I

Final approach guidance to touchdown:

- Centre line alignment guidance for a distance of 900 m before the threshold.
- An indication of distance 300 m before the threshold.
- Touchdown zone guidance.

Precision approach runway — Category II

Final approach guidance to touchdown:

- Centre line alignment guidance for a distance of 900 m before the threshold.
- Indications of distance 300 m and 150 m before the threshold.
- Touchdown zone alignment guidance for a distance of 300 m before the threshold.
- Touchdown zone guidance.

Roll-out guidance:

- Distance remaining information.

Taxiing guidance:

- Exit taxiway guidance including edge and centre line delineation.
- Taxiway centre line delineation with change-of-direction coding.

Precision approach runway — Category III

The operating requirements for visual aids in Category III meteorological conditions are, from the standpoint of configuration for approach and landing, the same as those provided for Category II meteorological conditions. Photometric characteristics of lights adequate for Category I and II operations need to be modified to provide increased vertical coverage, especially for large “eye-to-wheel height” aircraft.

1.3.6 Although pilots operating in Category III meteorological conditions are provided with the same visual aids used in Category II conditions, the time to obtain visual guidance from the system decreases in proportion to the lower meteorological conditions encountered during the approach. Visual guidance in the higher Category IIIA visibilities may be established with the approach lighting system, enabling the pilot to judge flight path with respect to alignment with the centre line. In Category IIIB and IIIC conditions, however, visual contact is not established until the aircraft is over or on the runway. It is not possible to judge the approach slope using visual aids in such low visibilities.

1.3.7 When operating on the surface in lower RVR conditions at major airports, additional visual signals are often needed. Two examples of these signals are stop bars and runway guard lights, as contained in Annex 14, Volume I, Chapter 5. This requirement also applies to major airports in better visibilities, but the requirement is stated in this section because the need is greatest when the visibility is lowest. Such systems are not visual guidance requirements but are aids to the control of aircraft movements and help to prevent collisions between aircraft operating on the surface, with particular emphasis on separation of aircraft movements on the landing and take-off runways from other slow-moving taxiing aircraft.

1.4 HOW VISUAL AIDS AND VISUAL CUES SERVE PILOTS

General

1.4.1 Establishing and maintaining dynamic three-dimensional orientation with the runway during approach and landing are complex, difficult piloting tasks, particularly during conditions of limited visibility (IMC). Once on the ground, pilots taxiing aircraft in all conditions require visual aids up to and including the point of docking. Section 1.3 lists operating requirements. This section describes the interrelationship between a pilot, the aircraft, and the visual and non-visual aids, particularly emphasizing how ground visual aids provide information and guidance.

1.4.2 **Frame of reference.** Insight into the importance of this pilot/machine relationship relative to visual flight can be gained by observing a pilot seated at the controls of the aircraft; the vertical seat adjustment is used by the pilot to achieve an eye position that provides a good view of the bottom edge of the windshield and the horizon, i.e. the frame of reference for visual flight. This eye position is an aid in judging the angle of the aircraft with visual aids while approaching the runway, the most important angle being the intersection of the flight path of the aircraft with the ground — the aiming point. The pilot’s chosen eye position is influenced by the over-the-nose vision angle, which is commonly called the cockpit cut-off angle. The bottom of the windshield is used to establish and maintain visual level flight and to assist in judging the angle of bank with the horizon or transverse components of visual aid systems when the horizon is obscured. Thus, it can be seen that the windshield of the aircraft plays an important role as a pilot aid in visual flight.

1.4.3 Aircraft are equipped with alignment devices which assist pilots in positioning their eye height so that the forward down-vision (cockpit cut-off) will coincide with the design eye position for the aircraft being flown. Use of these alignment devices is especially important when operating aircraft in low visibility conditions. An eye position that is below the datum design will increase the downward cut-off, thereby reducing the pilot's view of the available visual cues.

Visual aids for visual meteorological conditions (VMC)

1.4.4 The dynamics of the visual world as seen by pilots are important in the design of visual aids. Ordinarily in speaking of perceived motion, reference is made to the "movement of an object". In dealing with a pilot's use of visual aids, however, what is involved is the "movement of the observer" which is accompanied by a perceived expansion of the visual scene as the pilot directs the aircraft toward the runway. The point towards which the flight path is directed is the centre of expansion — the one point where visual cues are motionless. The perceived speed of visual cue movement increases outward from the centre, being greatest in the area between the centre of expansion and the position of the observer.

1.4.5 **Airport visual acquisition.** Pilots determine airport location by several methods depending upon its size and the nature of available visual and non-visual aids. By day, large runways are visible in good weather for long distances, the distance varying with aircraft height, direction of sun, contrast between runway and surrounding terrain, etc. Location of small airports, particularly those having unpaved runways, is often more difficult. Non-visual aids and/or map reading are basic aids during both day and night, the airport beacon being an extremely valuable aid at night for airports not served by non-visual aids.

1.4.6 **Airport identification.** Identifying airports is often a problem for the less experienced pilot, particularly when airports are close together. Some small airports display the airport name on a taxiway or a hangar roof, and others display an identifier code instead of the airport name. Few airports illuminate displayed names or codes so that they are legible for identification purposes at night. Identification beacons are rarely used. An alternating green/white beacon denotes a land airport, and an alternating yellow/white beacon denotes a water airport. In some States, the airport beacons at civil and military airports are coded so as to distinguish between these two classes of airports.

1.4.7 The following visual aids, where provided and where radio communication is not available, are viewed by

the pilot usually from a position close in and at a height well above the traffic pattern altitude so as to avoid other aircraft operating in the pattern. (The colour of these aids should provide maximum contrast with the surrounding terrain.) The pilot then proceeds to join the appropriate traffic pattern in preparation for landing.

Landing information

1.4.8 Wind direction indicators (wind socks) are important visual aids for all runway ends. Large wind direction indicators are particularly important at airports where landing information is not available through radio communications. On the other hand, landing direction indicators are seldom used due to the necessity and, consequently, responsibility, of changing their direction as wind direction shifts. Visual ground signals for runway and taxiway serviceability are contained in Annex 2. (See also Chapter 3 of this manual.) Annex 14, Volume I, contains specifications for runway designation markings.

1.4.9 A fabric wind cone is generally the type preferred by pilots because it provides a general indication of wind speed. Cones that extend fully at wind speeds of about 15 kt are most useful since this is the maximum crosswind landing component for small aircraft.

Circling guidance

1.4.10 In VMC, most landing traffic patterns require initial entry at a 45-degree angle with the downwind leg (Figure 1-3). Pilots position their aircraft on the downwind leg by judgement of distance from the runway and angle of the runway below the horizon. Tracking the downwind leg is normally not a problem since the crosswind component is usually quite low. Aircraft height during the downwind leg is controlled with reference to the aircraft altimeter and the horizon ahead of the aircraft.

1.4.11 The runway threshold is used as a reference point for establishing the base leg. Pilots of small aircraft may start the turn to base leg as the aircraft passes beyond the threshold, whereas pilots of large aircraft extend the downwind leg to establish a longer final approach leg. Pilots watch the runway angle decrease with respect to the aircraft so that they can turn toward and intercept the final approach course as the runway rotates to a point perpendicular to the horizon. The pilots of all these aircraft have the same requirements: the need to fix their position relative to the threshold, and guidance to pick up and hold the extended runway centre line on final approach.

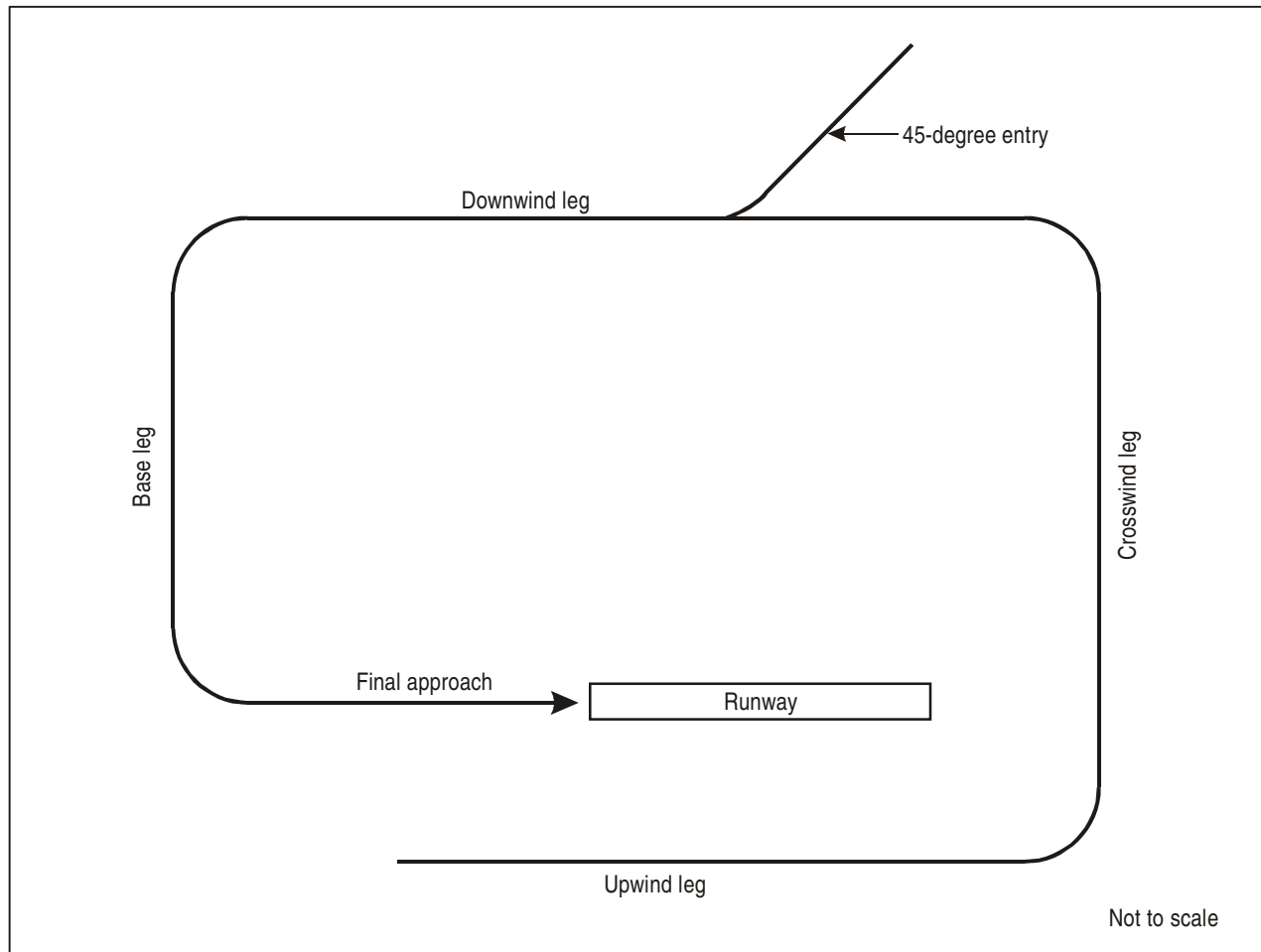

Figure 1-3. Standard traffic pattern for VMC

Final approach, flare and landing

1.4.12 This phase of piloting an aircraft is quite difficult and involves complex estimates of distance, height, drift and angle of flight with respect to the runway.

1.4.13 When aircraft are operated in VMC, the weather minima usually assure the pilot a horizon reference for piloting the aircraft using outside visual cues. The horizon may be the real horizon or it may be an apparent horizon — an observed or imaginary horizontal plane reference line presented by visual ground cues, cloud patterning, or sky/ground lighting demarcation in the absence of a clear view of the true horizon. When the landing runway is viewed in good visibility, aircraft location with respect to

the runway environment (unlike IMC) is not a problem. The final approach phase is divided into a sequence of two parts: first, approaching the threshold, and second, after the runway threshold has been crossed, the landing.

1.4.14 On final approach, the path which the pilot desires to follow may be regarded as the intersection of two planes — one, the inclined plane of the optimum approach slope, and the other, the vertical plane passing through the runway centre line.

1.4.15 To achieve this aim, the pilot must continuously know six variables:

- a) displacement relative to each reference plane;

- b) rate of closure with each reference plane, i.e. rate information; and
- c) rate of change of rate of closure relative to each reference plane, i.e. rate/rate information.

1.4.16 Pilots are continually matching displacement and rate indications so as to achieve zero displacement and zero rate of change of displacement as end conditions; or put another way, they must know:

- a) where they are at the moment;
- b) where they are going at that moment; and
- c) where they will be in a few moments' time.

The visual indications associated with these two planes differ greatly and are considered in 1.4.17 and 1.4.18.

Azimuth guidance

1.4.17 Zero displacement relative to the vertical plane (lateral displacement) is indicated by the perspective image of the runway and of the approach lights, where provided, being perpendicular to the horizon. Since the runway by itself has considerable length, the visual cue to displacement (variable 1.4.15 a) above) is instantaneous. The track heading and the rate of change of track heading (variables 1.4.15 b) and c) above) are not instantaneous, but errors can be corrected in a manner resulting in minor deviations from the desired track as the pilot proceeds inbound during final approach. Thus, the runway, or the runway edge lights, can be considered as visual cues enabling pilots to align aircraft quickly and maintain alignment with small deviations from the extended centre line of the runway.

Approach slope information

1.4.18 Visual approach slope indicator systems provide approach slope guidance, but other visual aids associated with the runway can only provide basic cues to approach slope angle being achieved. When pilots fly visual approach slope indicator systems, they are relieved of a considerable workload in judging the correct approach slope angle. The procedure to be used when glide slope guidance is not available is described below.

1.4.19 As the aircraft approaches the landing runway prior to initiating descent for final approach, the pilot

observes the visual cues associated with the runway moving downward within the aircraft windshield. When the point along the runway at which the aircraft will be aimed during descent (the aiming point) is depressed below the horizon at the apparent desired approach angle, the pilot initiates descent by aiming the aircraft at the selected aiming point. The aiming point selected varies with aircraft size and runway length available for landing. Small aircraft are normally aimed at or just beyond the runway designation marking; large aircraft are normally aimed at or in the near vicinity of the aiming point marking that is located according to the landing distance available.

1.4.20 Displacement above or below the ideal approach slope angle results in a vertical extension and compression of the perspective image of the runway, accompanied by changes of runway edge angles with the runway threshold and with the horizon (Figure 1-4). Experienced pilots can tell whether they are near this desired approach angle by comparing the actual runway image with the "ideal" runway image carried in their minds, an image impressed there by training and practice. As the aircraft descends, the runway edges appear to rotate towards the horizontal. As aircraft height increases, the runway edges appear to rotate towards the vertical.

1.4.21 As the aircraft descends through heights of approximately 45 m to 20 m above the runway (depending on approach slope angle and speed), the pilot becomes increasingly aware of the expanding runway scene as visual cues are observed to move rapidly outward from the centre of expansion. This is due to the speed of the "flowing visual field" increasing at a rate inversely proportional to the distance of the pilot. It is at these relatively low heights that the pilot becomes fully aware of the precise direction of the aircraft flight path, sensing the point of zero motion and, if required, making final adjustments to the flight path to ensure a safe landing within the touchdown zone of the runway.

Flare and landing

1.4.22 Aircraft flare is a manoeuvre in which the aircraft flight path is changed from the final approach angle to a path substantially parallel to the runway surface prior to landing. The flare may be initiated well ahead of the threshold for large aircraft and over the threshold for small aircraft.

1.4.23 The visual aids used in flare and landing are those that mark the threshold, outline the edges of full-strength pavement and delineate the touchdown zone

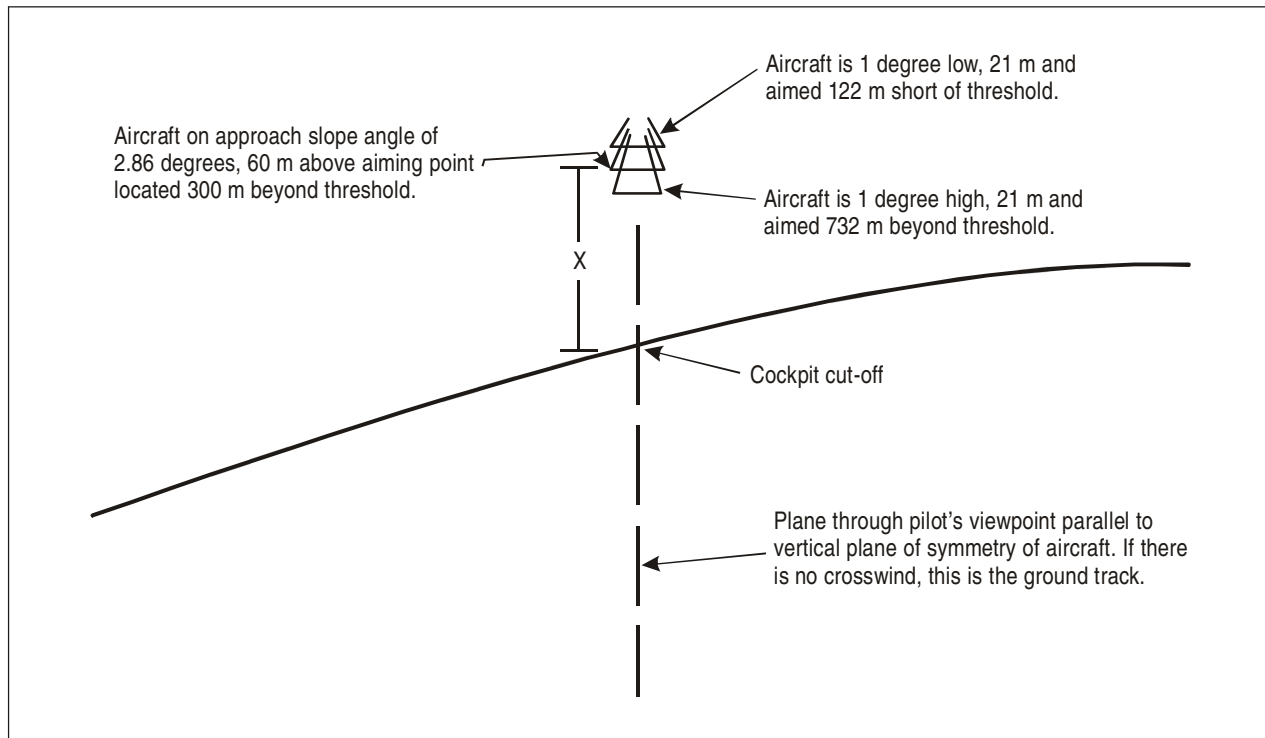

NOTES:

1. The convergence of the runway edges becomes greater when height is reduced.
2. The distance, X, of the image above the cockpit cut-off line provides pilots with a rough idea of their approach slope angle when the horizon is not visible.
3. Distance from aiming point is 1 200 m. Visual range is 3 350 m, and 2 438 m of the runway are visible.

Figure 1-4. Height and aiming errors as they appear when only the runway is visible and there is no horizon

and the runway centre line. By day the edges are normally seen due to the contrast of runway pavement with surrounding terrain, while runway edge lights are needed at night. Runway threshold and centre line markings are used during both day and night. The visual aids provide alignment guidance. Texture of the pavement surface is the primary source of height appreciation for both day and night (aircraft landing lights being used at night) unless, of course, touchdown zone lights are available and used for VMC operations. Runway lighting and, in particular, runway centre line and touchdown zone lighting accentuate rate cues and height appreciation.

Roll-out guidance

1.4.24 Roll-out commences immediately following contact of the main landing gear wheels with the runway surface. Runway centre line markings or lights provide primary visual alignment guidance during roll-out. Runway edge lighting is used at night to supplement the centre line particularly where runway centre line lighting is not available.

1.4.25 Where provided, the colour coding of the runway centre line lighting assists the pilot in judging the

aircraft's position when decelerating during the roll-out. The coding consists of alternating red/white lights within the zone 900 m to 300 m ahead of the runway end and all-red lights within the zone 300 m on up to the runway end. Touchdown zone markings are useful in judging position during the roll-out. The fixed distance markings indicate a position 300 m from the runway end. Runway end lights mark the limit of the runway available for roll-out.

Runway exit guidance

1.4.26 As the pilot decelerates the aircraft to exit speed, prompt exiting of the runway is important, especially at busy airports. Where high-speed exit taxiways are provided, prompt egress can be realized. Pilots require prior notice of the exit point; if this is lacking, all too often they are compelled to roll along searching for an exit which frequently is seen too late for use. Taxiway centre line lighting extending out to the runway centre line, as provided for in Annex 14, Volume I, for other than rapid exit taxiways, is a useful aid at night.

Taxiing guidance

1.4.27 Generally, taxiing guidance inbound to the terminal or outbound to the runway for departure is not a major problem for pilots who are familiar with the airport and operating in VMC. Pilots of large aircraft must carefully negotiate taxiway intersections, particularly at night. The guidance systems discussed in Chapter 10 are provided to overcome problems with taxiing guidance.

Take-off guidance

1.4.28 From a visual guidance standpoint, the take-off phase is not a problem. The pilot taxis into take-off position, using runway edge or centre line lights at night to centre the aircraft on the runway. Alignment guidance is provided by the runway centre line markings and/or lighting. The runway centre line light coding, where provided, and the runway end lights are of primary use when a pilot aborts the take-off run during night-time or low visibility conditions.

Visual aids for instrument meteorological conditions (IMC)

1.4.29 Paragraphs 1.4.4 through 1.4.28 discuss flight in VMC and analyse the design of ground visual aids for

assisting pilots. These same analyses apply to this part when, in conducting an instrument approach, a pilot, from a predetermined point, completes the approach, flare and landing solely by reference to outside visual cues.

1.4.30 Only experienced pilots, qualified in instrument flying and in the use of radio, are permitted to operate aircraft in IMC. However, approaches, landings and take-offs made in IMC, particularly in visibilities below 800 m, necessitate the use of more powerful and more sophisticated visual aids than those needed in VMC.

Airport acquisition

1.4.31 Determination of airport location in IMC is dependent primarily upon use of non-visual aids. Where non-precision approach procedures are established, ground visual aids assist in locating airports, particularly at night. Approach lights, runway edge and circling guidance lights, and the airport beacon are all used depending upon the operation being conducted.

Airport identification

1.4.32 Airport identification is a problem only when using a non-precision aid. Airport identification is assumed by the pilot when a runway environment is sighted at the appropriate computed flight time from the final approach fix. Where two airports are in close proximity, it is quite possible for pilots to land at the wrong airport when using non-precision instrument approach aids if the runways are oriented in approximately the same direction. Under these conditions, an identification beacon could prove to be a most useful visual aid.

Landing information

1.4.33 In order to prevent time-wasting and unnecessary missed approaches, it is essential that pilots obtain all pertinent landing information (ceiling and visibility, wind direction and speed, runway-in-use, etc.) prior to initiating an instrument approach procedure. Those visual aids which provide landing information in VMC serve no useful purpose in IMC.

The non-precision approach runway

1.4.34 A straight-in, non-precision approach procedure should not require a final approach heading change to the

landing runway in excess of 30 degrees (Figure 1-5). Non-precision approach procedures normally authorize circling manoeuvres to other runways (if any) in addition to the runway within 30 degrees of the final approach course. The piloting task is less complicated, and thus safer, where the final approach is aligned with the landing runway. The degree of difficulty can be considered to be in direct proportion to the magnitude of heading change of the final approach course with the runway.

1.4.35 Non-precision approach procedures are developed so that the aircraft can descend to the minimum altitude established for the procedure (Figure 1-6). Azimuth guidance is provided by the approach lighting system (ALS) where available. If an ALS is not provided, higher visibility minima must be applied to allow the pilot time to intercept the extended runway centre line, using runway contrast with the surrounding terrain or runway edge lights for visual guidance.

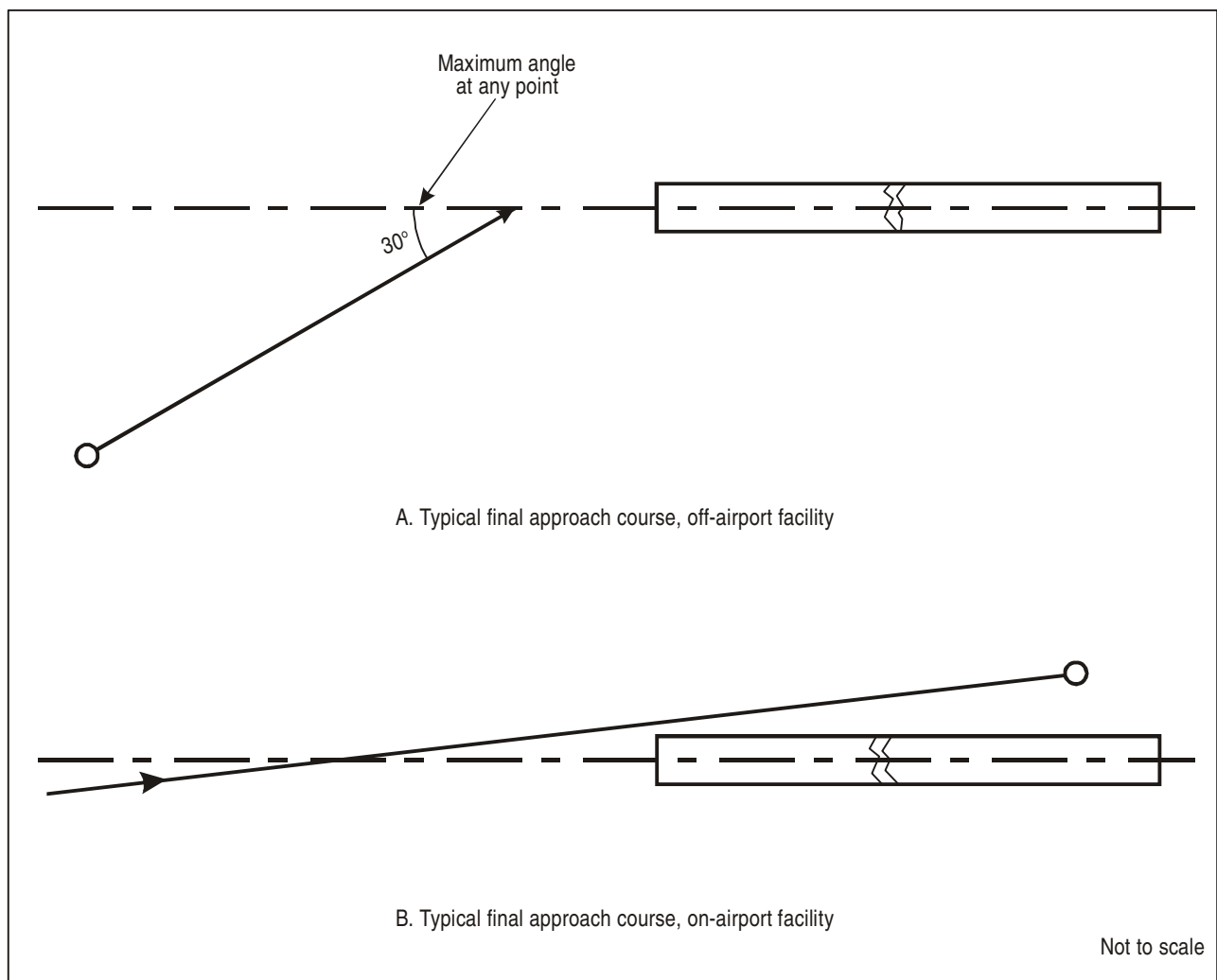

Note.— In both A and B above, the desired intersection point with the extended runway centre line is at least 900 m from the runway threshold.

Figure 1-5. Examples of straight-in landings, non-precision aids

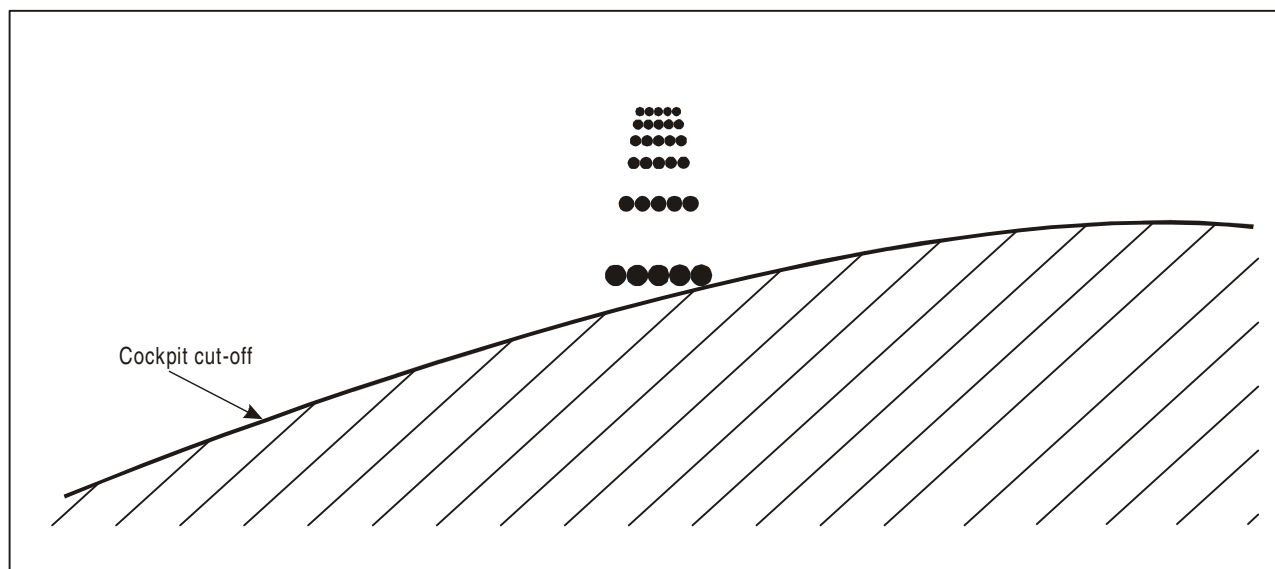

Figure 1-6. A 150 m visual ground segment as seen by a pilot flying at a height of 15 m above the approach lighting system

Circling guidance

1.4.36 Circling to land following a non-precision approach when the meteorological conditions are at or near the minima established for the procedure is a piloting task requiring considerable skill. Pilots must establish visual reference with the runway while flying their aircraft as low as 90 m above obstacles. The visual cues are similar to those required for VMC under 1.4.10 and 1.4.11; however, pilots make greater use of aircraft instruments to assist in maintaining alignment and height. Apparent size of known objects, apparent motion of objects, eclipsing of one object by another and gradients of natural texture are important cues to height/distance judgements during daylight. Omni-directional runway edge lighting can be a useful aid for this type of operation.

Final approach, flare and landing

1.4.37 As the aircraft is aligned with the runway following a straight-in or circling approach, ground visual aids are used in ways quite similar to those set forth above for VMC operations, with a few exceptions. Since the horizon is not visible, the approach slope angle (where visual approach slope indicator systems are not available) is obtained by the height of the runway aiming point above

the lower edge of the windshield, but this is not a consistent and reliable cue due to aircraft attitude changes. As runway edges become sufficiently visible, they assist the pilot in judging the approach slope angle to the aiming point. Alignment guidance may not be instantaneous because a large part of the runway is obscured during final approach.

1.4.38 Visual approach slope indicator systems are most important visual aids. Pilots are severely handicapped at many locations in conducting approaches without visual approach slope indicator systems, especially where approaches are conducted over water or featureless terrain.

The precision approach runway

1.4.39 The same type of non-visual ground aid (ILS/MLS) is used for all precision approach categories. Greater accuracies are required of both ground and airborne equipment to comply with certification requirements for operating in the lower visibilities. These greater accuracies are reflected in the flight path envelope requirements contained in Annex 14, Volume I, Attachment A, Figure A-4.

1.4.40 From the pilot's point of view, the major concern with operating into lower visibility categories is that, as the instrument approach is continued to lower

minima (and thus the pilot is on instruments nearer the threshold), the instrument phase is lengthened and the visual phase is shortened. For example, the normal minimum decision height (DH) at which visual aids are used is 60 m for Category I operations and 30 m for Category II operations; no DH is applicable to Category IIIA and IIIB operations; and, finally, there is no reliance on visual aids for Category IIIC operations. The actual decision height at an airport will depend on local conditions.

1.4.41 As the instrument phase is flown, the pilot seeks to know the aircraft's position laterally, vertically and longitudinally and what the crab angle is likely to be when visual contact is made with the lighting system. As the lighting system is sighted, the pilot must quickly verify the position of the aircraft and decide whether there are sufficient cues to continue the approach below the DH, if applicable.

Final approach — azimuth guidance

1.4.42 As a short section of the approach lighting system (ALS) centre line comes into view, displacement with the centre line can be quickly ascertained. Where side row barrettes are provided within the inner 300 m of the system, pilots are provided with additional information concerning the magnitude of the displacement. About three seconds of time are needed to decide what the flight path is relative to the centre line (variable b), 1.4.15). If the aircraft is aligned, the ALS centre line elements appear symmetrical. If not aligned, the ALS centre line elements appear skewed, and the pilot must decide whether the aircraft is tracking into the centre line, parallel to it, or away from it. In either of the latter two cases, the magnitude of the correction that can be executed safely depends not only on approach speed and distance from the threshold but also on the aircraft's manoeuvrability and the runway length available for landing. This vital decision involving many variables has to be made in a few seconds of time.

1.4.43 Side row barrettes in the approach lighting pattern are especially helpful in the lower visibilities. They accelerate decision making due to their being located in line with the barrettes of the touchdown zone, thus providing a positive fix relative to the zone on the runway within which the aircraft should land. This inner zone of the ALS provides excellent cues for judging the roll attitude of the aircraft — cues that are essential to maintaining alignment with the runway. When the aircraft arrives at the minimum Category II DH of 30 m, the runway is less than about five seconds away; thus, the decision to continue the approach is

in a large measure based upon whether the aircraft flight path will be within the side row barrettes.

Final approach — height information

1.4.44 To obtain approach slope guidance from visual aids when a visual approach slope indicator system is not provided or is not visible due to low visibility requires an aiming point to be visible. It is thus apparent that operations in the lower visibilities of Category II and below are conducted without benefit of visual approach slope guidance (Figure 1-4). In these conditions, when an aircraft descends below the glide path to heights of about 15 m above the ALS, the transverse components define a linear-appearing plane where perception of height is good provided the visibility enables the pilot to see and maintain a visible segment equivalent to about three seconds of flight time. However, appreciation of rate-of-descent or glide slope angle is poor (Figure 1-6).

Flare and landing

1.4.45 Prior to the development of runway centre line and touchdown zone lighting, pilots were faced with an extremely difficult task when landing in visibilities equivalent to current Category II, and lower, meteorological conditions. The problem was most severe at night and the condition was appropriately named the "Black Hole". Aircraft landing lights were useless because the fog was illuminated rather than the runway surface, creating even a more difficult visual environment. Centre line and touchdown zone lighting provide pilots with azimuth guidance and height information — the solution to the "Black Hole" problem. The transverse components of touchdown zone lighting supply roll guidance, the key to maintenance of alignment of the aircraft with the runway. These lights also delineate the lateral (left/right) and longitudinal limits of the touchdown zone, particularly for large aircraft.

1.4.46 During daylight hours, runway markings within the touchdown zone provide azimuth guidance and height information for Category I operations. Markings are also important visual aids for Category II and III operations, especially during daylight when background brightness is at high levels.

1.4.47 The individual lights that compose the runway centre line and touchdown zone components are seen as point sources when approaching the runway, but during flare at low heights the nearer point sources change into linear (streaking) sources. The distance ahead of the aircraft

at which the change from point to linear sources occurs varies with aircraft speed and cockpit height. The streaking effect is due to the high angular rate at which the lights move across the retina of the eye; that is to say, they cannot be fixated by eye pursuit movements. The effect is an increase in the pilot's perception of the rate of change of flight path.

Roll-out guidance

1.4.48 In low RVR conditions, pilot reliance upon runway centre line lighting increases and reaches a point where the centre line is all that is seen in Category III conditions. Centre line lighting and marking are still effective for ground steering in very low visual ranges, especially where the pilot is over the lights. Displacement of 5 m to 9 m left or right is usually the maximum encountered, but displacements of the larger magnitude significantly increase the task difficulty in the lower visibilities. Figure 1-7 shows that these lights will move at a rather large angle with the longitudinal axis of the aircraft. Pilots will normally steer their aircraft toward and over (or nearer) the centre line to improve azimuth guidance under such conditions.

Runway exit guidance

1.4.49 Because exit taxiway visual acquisition can be a major problem when operating at night, when the surface is wet, or in RVRs below about 400 m, the green taxiway centre line lights are extended into the runway according to Annex 14, Volume I specifications. Even in VMC, experience has shown that exiting runways can be slow unless these lights and taxiway edge lights are provided. Pilots use taxiway centre line and edge lights to determine if use of the exit is appropriate and safe considering the speed of the aircraft. Without well-defined pavement edges, pilots will not exit the runway until the aircraft speed is sufficiently low to ensure that the aircraft will remain on the paved surface. High-intensity lighting, halo effects about lights, high ambient light levels associated with fog, rain on the windshield — these factors, combined with pilot fatigue, create a firm operating requirement for good exit lighting at night, when the surface is wet, and in low visibility operations.

Distance information

1.4.50 Approach and runway lighting incorporate distance information in several stages throughout the full length of the combined systems. These are outlined in

Table 1-1. Availability of visual ground aids, which keep pilots informed of their position during low visibilities, is a major safety feature of the system.

Taxiing guidance

1.4.51 Taxiing in VMC is normally routine unless pavement configurations are complex, confusing or congested. Taxiing in IMC (particularly at night) becomes progressively more difficult as visibility decreases, even for pilots thoroughly familiar with the airport. Visual aids required for safe and expeditious movement of aircraft on the surface are continuously being developed. Pilots use signs, markings and lights to inform them that aircraft tails are clear of runways and other taxiways. Pilots acquire advance notice when approaching a curve in the taxiway from the reduced spacing of the taxiway centre line lights. Upon entering the apron, delineation of apron taxiways is as important as delineation of other taxiways. When departing the apron in low visibilities or where pavement configuration is complex, confusing or congested, locating and identifying the taxiways to be used can be a major task.

1.4.52 Selectively switched taxiway centre line lighting, including such lighting on apron taxiways, to delineate the taxiing route, provides an effective visual aid solution. Where selective switching is not provided, signs are the most useful visual aid to pilots.

Docking/parking guidance

1.4.53 In the lower visibilities, centre line guidance into the docking point is needed until docking signals come into view. Docking signals providing left/right guidance, distance to docking position, an indication of rate of closure, and a stop command for the pilot position that does not require head movement or marshaller assistance constitute the ideal visual docking guidance system. Where docking is not involved, visual aids are needed to assist pilots in parking within open apron areas, with or without marshaller assistance, as necessary to clear all other objects in the parking area. General apron lighting should illuminate parking guidelines as well as objects that might interfere with aircraft movements and should not degrade docking or parking signals.

Take-off guidance

1.4.54 Take-off guidance is provided by runway centre line lighting and marking. Alignment guidance is excellent

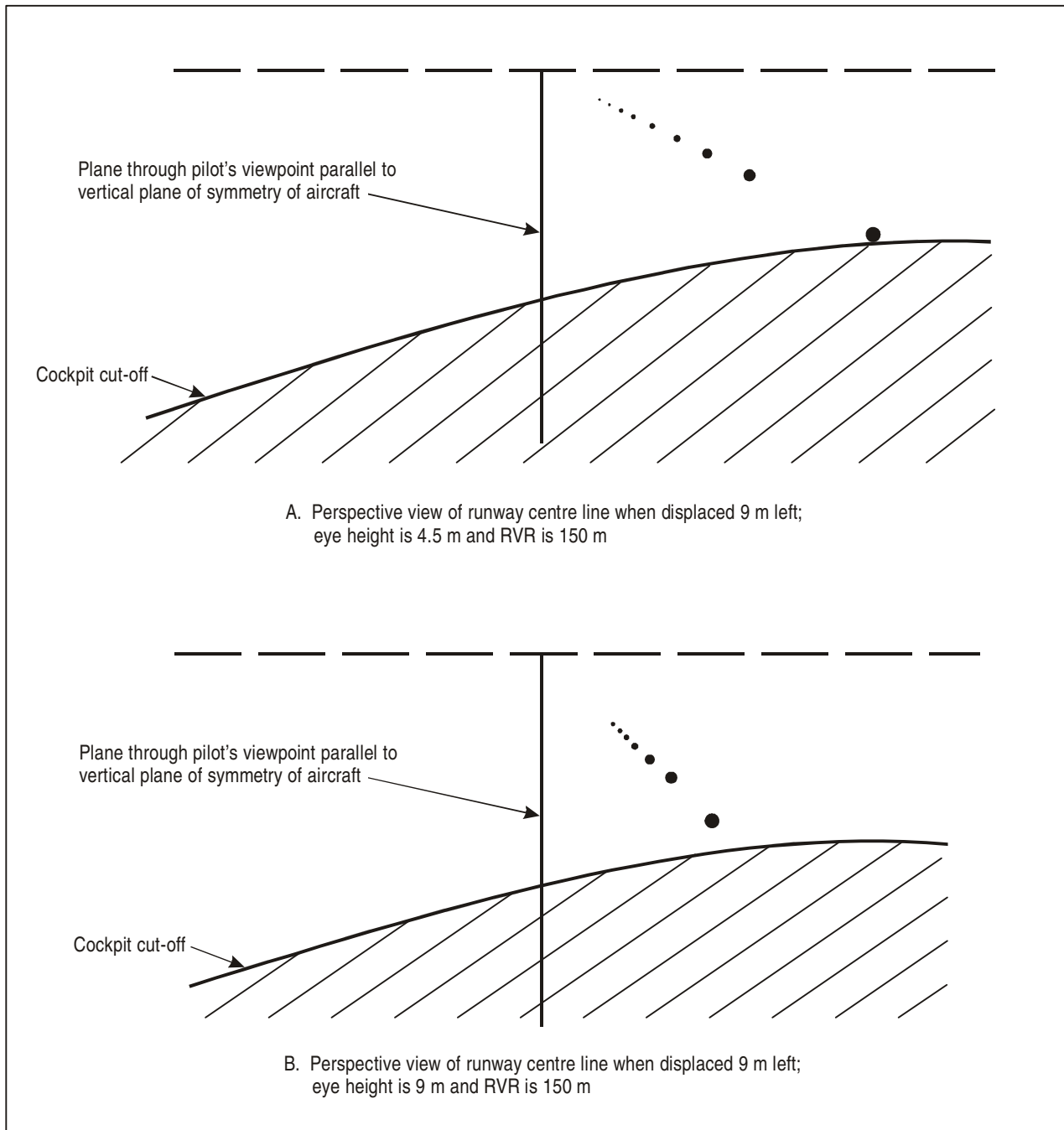

Figure 1-7. Perspective view of runway centre line from different eye heights

Table 1-1. Coding of distance for Category II and III landing operations

System	Location	Colour	Configuration	Operating significance
Approach lighting system with distance-coded centre line	Outer 600 m	White	Configuration consisting of three light sources in the outermost sector and two light sources in the inner sector	Aircraft position above DH (Cat II)
Approach lighting system with barrette centre line	Outer 600 m	White	Centre line consisting of five light barrettes with a condenser discharge light at each station	Aircraft position above DH (Cat II)
Approach lighting system, both types	300 m to 30 m	White	Crossbar at 300 m point	A conspicuous signal at or near DH (Cat II)
		White	Centre line of barrettes	Centre line alignment
		Red	Side rows in line with touchdown zone lights	Marks lateral deviation limits for landing. If pilots are outside the signal, they should abort the approach unless tracking toward centre line.
		White	Crossbar at 150 m point	Flare anticipation for some large aircraft, imminence of threshold. (The entire sector marks the pre-threshold area but individual components serve the pilot in different ways.)
Runway threshold	Runway threshold	Green	A transverse row that may be broken in the central portion	Beginning of landing surface
Centre line and touchdown zone	First 900 m of runway	White	Runway centre line	Centre line alignment
		White	Touchdown zone barrettes — about 9 m each side of centre line	Lateral deviation cues. (The entire sector defines a safe landing zone.)
Centre line	Central part of runway	White	Defines the central portion of runway	A zone for decelerating
Centre line	Final 900 m to 300 m of runway	Alternating red and white	Alternating red/white lights located in the first 600 m of the sector	Warns pilot of approach to final 300 m zone of runway
Centre line	Final 300 m of runway	Red	All red lights for 300 m	Defines final zone of runway
Runway end	Runway end	Red	A transverse row that is normally broken in the central portion	The end of the runway

and operations can be safely executed in RVRs of approximately 100 m. The coded centre line for the final 900 m is most valuable in the event of aborted take-off, since the cues enable the pilot to use judgement in resorting to emergency braking procedures to stop within the confines of the runway.

1.5 DESIGNATION OF HIGH-, MEDIUM- AND LOW-INTENSITY LIGHTING

1.5.1 Throughout this manual, the output of different types of lights that are provided for a particular function, e.g. obstacle lights or runway lights, are broadly classified as being high-, medium- or low-intensity lights.

1.5.2 The range of intensities within a high, medium or low classification is different for each functionality (type of light). Thus a high-intensity obstacle light may have an output of 200 000 cd, whilst a high-intensity approach light has an output of 20 000 cd.

1.5.3 The apparent discrepancy arising from the description of both of these examples as being high-intensity lights can be explained by noting the level of illumination at the eye when the lights are viewed from a typical operational range. Thus in good visibility conditions, a 200 000 cd obstacle light seen from a range of 3 km will provide a similar illuminance at the eye to that provided by a 20 000 cd approach light seen from a range of 1 km. In other words, a pilot will describe both types of lights as being high-intensity.

Chapter 2

Markings and Markers

2.1 GENERAL

2.1.1 This chapter supplements the specifications given in Annex 14, Volume I, Chapter 5, on markings and markers. Markings and markers provide essential information to pilots by their location, size and colour characteristics. Standardization is important. Where provided, markings and marker aids contribute to the safety and operational efficiency of aircraft and vehicle movements. Good maintenance of these aids is essential to ensure that the cues that they provide are available in all circumstances.

2.1.2 Additional guidance on apron markings is given in the Airports Council International (ACI)/International Air Transport Association (IATA) *Apron Markings & Signs Handbook* which gives examples of current best practices.

2.2 ADDITIONAL MARKING OF PAVED SHOULDERS

2.2.1 Aprons and taxiways may be provided with shoulder stabilization which has the appearance of pavement but which is not intended to support aircraft. Similarly, small areas within the apron area may have non-load bearing pavement which appears to be full strength. This stabilization may be provided to prevent blast and water erosion as well as to provide a smooth surface that can be kept free of debris.

2.2.2 On straight sections this stabilization may be readily recognizable by the provision of the taxi side stripe markings recommended in Annex 14, Volume I. At intersections of taxiways and on other areas where, due to turning, the possibility for confusion between the side stripe markings and centre line markings may exist or where the pilot may not be sure on which side of the edge marking the non-load bearing pavement is, the additional provision of transverse stripes on the non-load bearing surface has been found to be of assistance.

2.2.3 As shown in Figure 2-1, the transverse stripes should be placed perpendicular to the side stripe marking. On curves, a stripe should be placed at each point of tangency of the curve and at intermediate points along the curve so that the interval between stripes does not exceed 15 m. If deemed desirable to place transverse stripes on small straight sections, the spacing should not exceed 30 m. The width of the marks should be 0.9 m, and they should extend to within 1.5 m of the outside edge of the stabilized paving or be 7.5 m long, whichever is shorter. The colour of the transverse stripes should be the same as that of the edge stripes, i.e. yellow.

2.3 APRON MARKINGS

Objective of guidance on aircraft stands

2.3.1 The main objective of guidance on aircraft stands is to provide:

- a) safe manoeuvring of aircraft on the stand; and
- b) precise positioning of aircraft.

This objective can often be met by means of apron markings. Several lighting aids are used to supplement the guidance provided by apron markings at night and in poor visibility conditions. Of special interest are the aircraft stand manoeuvring guidance lights and the visual docking guidance systems, which are dealt with in greater detail in Chapter 12.

Safe manoeuvring of aircraft

2.3.2 Aircraft stands are, in general, arranged relatively close to one another so as to minimize as much as possible the paved area as well as the walking distance of passengers. The manoeuvring of aircraft, therefore, needs to be precisely

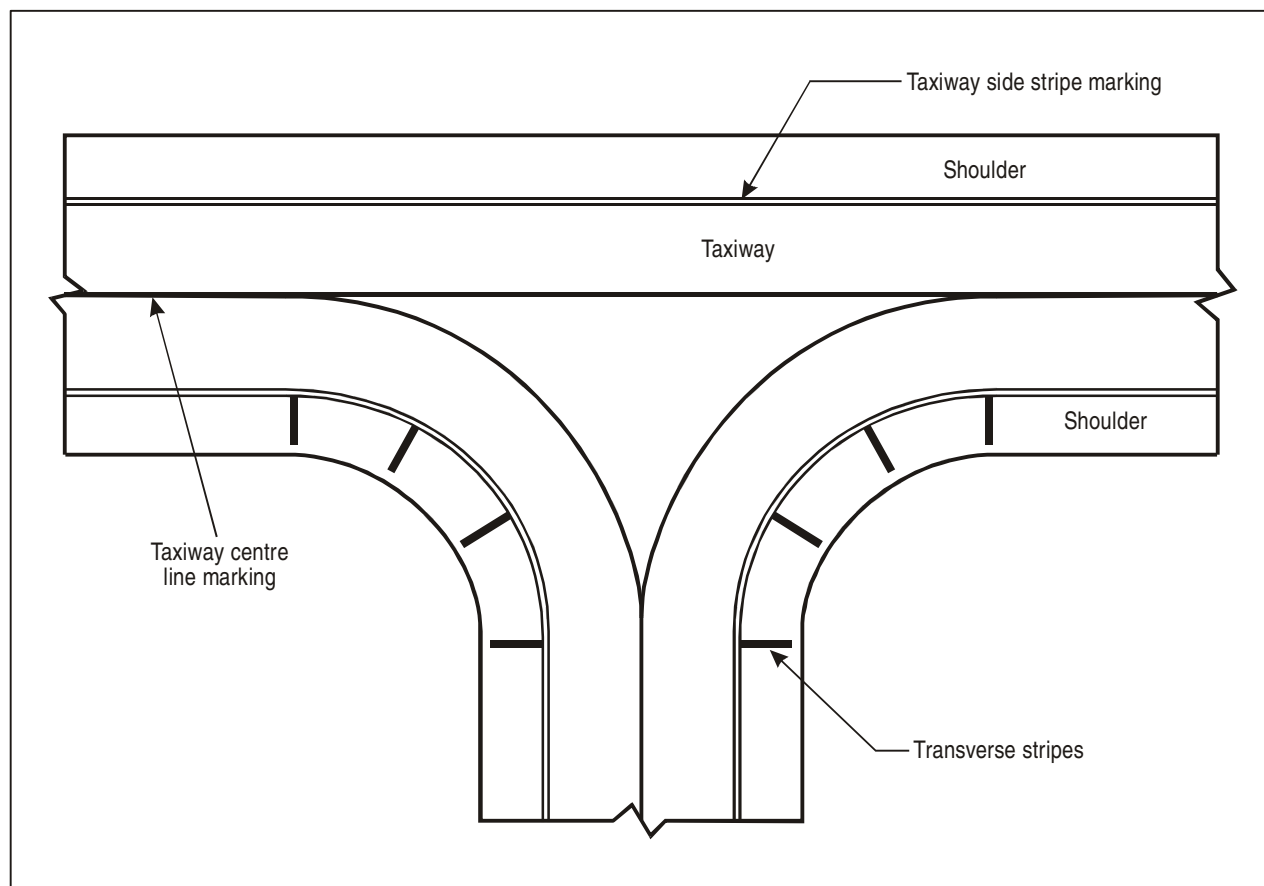

Figure 2-1. Marking of paved taxiway shoulders

controlled so that at all times they will be kept clear of the adjacent aircraft, buildings and service vehicles on the apron. Consideration should also be given to ensuring that the blast of the manoeuvring aircraft will not interfere with activities at the adjacent stand and that the marking is well within the castoring capabilities of all aircraft using the stand. The clearances between manoeuvring aircraft and other aircraft, buildings or other obstacles for various circumstances are given in Annex 14, Volume I, Chapter 3. Control of ground equipment and vehicles should be exercised to ensure that the aircraft manoeuvring area at the stand is clear. Ground equipment and vehicles should be kept outside predetermined safety lines when aircraft are manoeuvring or when the equipment is left unattended.

Manner of following guide lines

2.3.3 There are two recognized ways for aircraft to follow guide lines. In one, the nose of the aircraft (or pilot's seat) is kept over the line; in the other, the nose wheel traces the line. Annex 14, Volume I, Chapter 3, specifies that the taxiway curves should be designed so as to provide the required clearances when the cockpit of the aeroplane remains over the taxiway centre line markings. This is primarily because of the difficulty the pilot would have in ensuring that the nose wheel follows the guide lines. In some aircraft the nose wheel is displaced as much as 5 m behind the cockpit. The requirements for aircraft stand markings, however, are not comparable to those for taxiway

centre line markings. There are two differences in the manoeuvring of aircraft on aircraft stands:

- a) because of reduced area for manoeuvring, much smaller radii of turn are needed; and
- b) trained marshalls are often used to assist in the manoeuvring of the aircraft.

Accordingly, Annex 14, Volume I, Chapter 5, specifies that the aircraft stand markings be designed on the nose wheel on guide line principle.

Types of aircraft stand markings

2.3.4 Aircraft stand markings consist of guide lines to denote the path to be followed by aircraft, and reference bars to provide supplementary information. Guide lines may be separated into:

- a) lead-in lines;
- b) turning lines; and
- c) lead-out lines.

Lead-in lines

2.3.5 These lines provide guidance from apron taxiways into specific aircraft stands. They may be required to enable taxiing aircraft to maintain a prescribed clearance from other aircraft on the apron. They may be considered as important as the turning line to align the aircraft axis with the predetermined final position. For nose-in stands, the lead-in lines will mark the stand centre line to the aircraft stopping position. There will be no lead-out lines, and the tractor drivers will use the lead-in lines for guidance during the push-back manoeuvre.

2.3.6 Figure 2-2 shows a simple lead-in line. The advantage of this line is that it presents the most natural method of turning and it is least likely to be misunderstood. Its disadvantages are that it is not suitable for marking a stand where the aircraft is to be located centrally over the lead-in line and that it requires more apron space than the type of marking that can achieve this. The lines are to be followed by the aircraft nose wheel. When these lines are used, it should be noted that the track of the aircraft centre is inside the curve of the guide line. In some instances the apron area available may require the use of a different type of marking. Figure 2-3 shows an offset lead-in line. When the aircraft nose wheel follows these lines, the centre of the aircraft does not cut as far inside the curve but makes a

tighter turn. As a consequence, the size of stand positions need not be as great. It should however be noted that while this type of marking positions the aircraft centrally over the lead-in line, a given line can only be fully suitable for one single aircraft type or where the aircraft geometry, in terms of the wheel bases of all the different types using the stand, is virtually identical. Where it is necessary for a stand to be used by a variety of aircraft types and they do not have similar undercarriage geometry, yet the available space requires aircraft to be centrally positioned over the lead-in line, the aims are best achieved by using a short arrow at 90 degrees to the taxiway centre line as in Figure 2-4. One drawback of this arrangement is that the entry point and degree of turn needed to align the aircraft centrally over the lead-in line are left to the pilot's judgement.

Turning lines

2.3.7 Where the aircraft is required to make a turn on the stand prior to stopping or after "break away", a turning line may be needed for the aircraft to follow. The primary purpose of this line is to limit the turning of aircraft within the designated area so as to keep aircraft clear of obstacles and to aid in accurate positioning of the aircraft. The former is of special importance where clearances between the stand and near structures or other stands are marginal.

2.3.8 Figure 2-5 shows a typical example for a nose-wheel turning line. The line might well be supplemented by reference bars as shown and as discussed later in 2.3.15.

2.3.9 ***Straight portion of the turning line.*** The turning line should incorporate a straight portion at least 3 m in length at the final aircraft position. This provides a 1.5 m section prior to the final stopping position to relieve pressure on the landing gear and at the same time to correct the aircraft alignment, and a section 1.5 m long after the stopping position to reduce the thrust required and, thereby, blast on "break away". The length of the straight portion referred to above can be reduced to 1.5 m in the case of stands meant for small aircraft.

Lead-out lines

2.3.10 These lines provide guidance from stands to taxiways and ensure that the prescribed clearance from other aircraft and obstacles is maintained. These lines are shown in Figure 2-6. Where aircraft have to make a turn prior to leaving the stand to keep clear of the adjacent obstacles, the lead-out line may be as shown in Figure 2-6 a). Where the clearance from the adjacent stand is less marginal, the lead-out line of Figure 2-6 b) or c) might

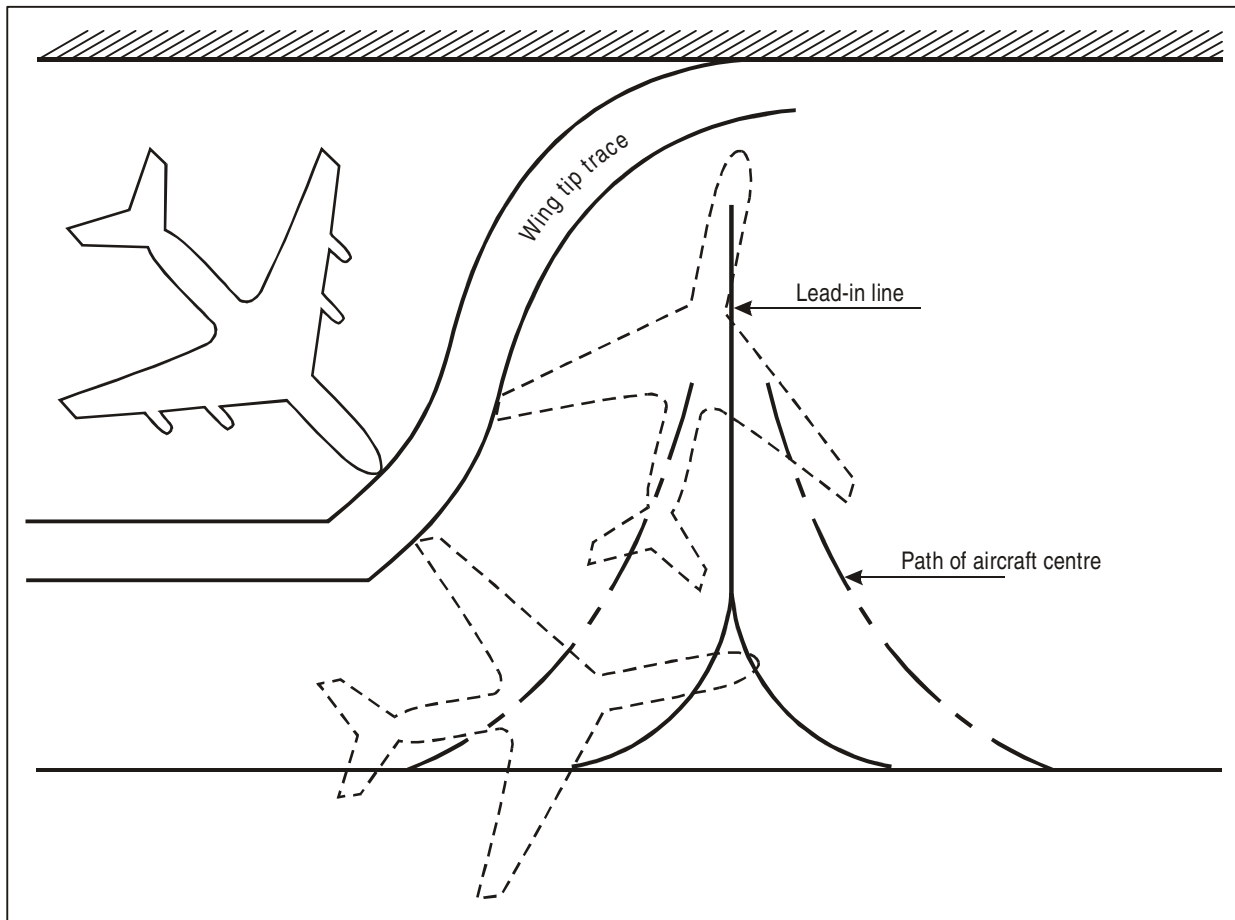

Figure 2-2. Simple nose-wheel lead-in line

be practical. Offset nose-wheel lead-out lines as shown in Figure 2-7 may be needed where clearances are marginal.

Method of computing the radii of curved portions of lead-in, turning and lead-out lines

2.3.11 Whether one uses a nose-wheel line or only a straight lead-in as in Figure 2-4, the assumed or marked radius must be within the turning capability of the aircraft for which the stand is intended. In calculating the radius, one needs to assess the likely effect of blast which can result from using too tight a radius. It is also possible for the minimum acceptable radius of turn to vary with operators even though they are using the same aeroplane. Further, the smaller the turn radius and the larger the nose-wheel angle, the more likelihood there is of tire migration. In other words, while one may have, for

example, 65 degrees of nose-wheel angle applied, the effective turn radius is equivalent only to some lesser angle, with possibly as much as a 5-degree loss. To determine the radii, therefore, one needs to consult the manuals issued by the aircraft manufacturers for airport planning purposes; the operators of the individual aeroplane types should also be consulted to find out to what extent they modify the manufacturer's guidance for any reason. The individual apron situation would then need to be studied to see whether further modification would be necessary.

Duplication of guidance

2.3.12 When a stand is used by different types of aircraft and alignment of aircraft is not of great importance, it may be possible to use one set of markings to serve all types. In such cases the largest turning radius is used. Any type of aircraft of the group can then manoeuvre with

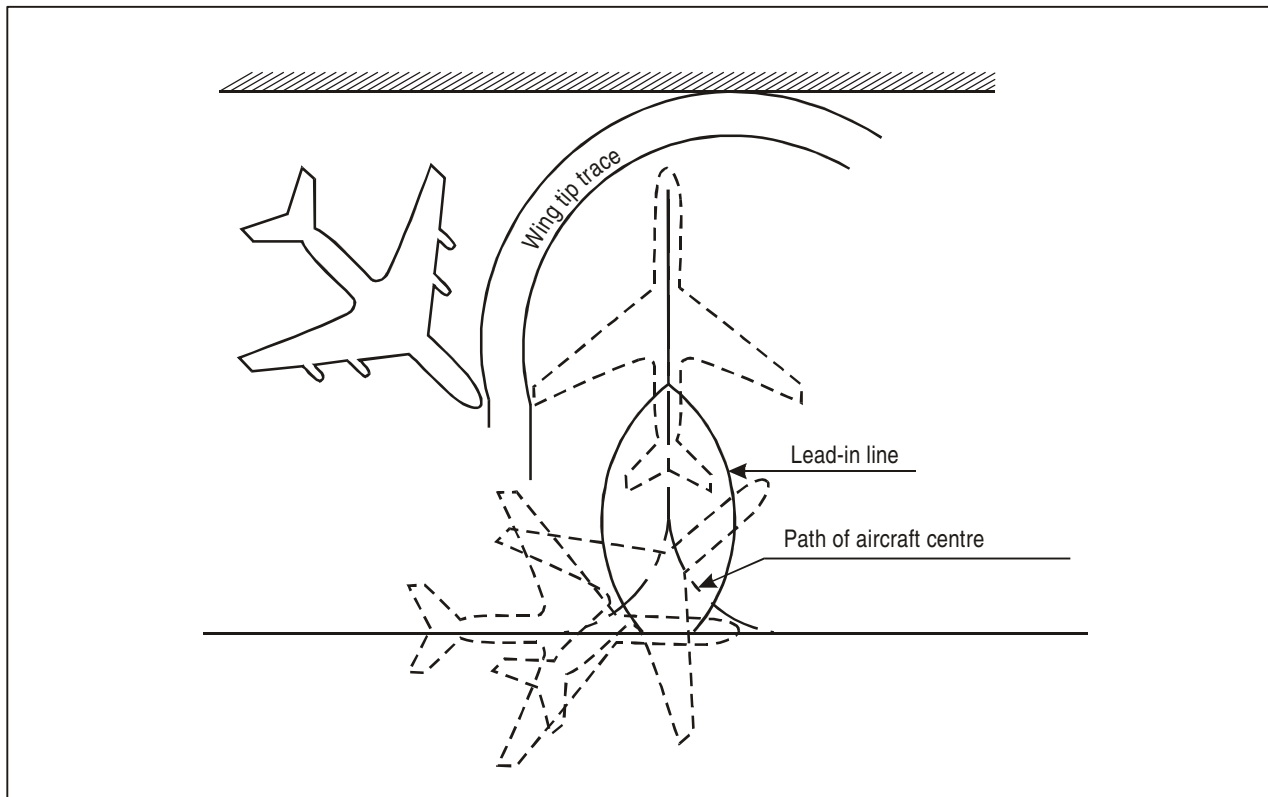

Figure 2-3. Offset nose-wheel lead-in line

sufficient clearance if the nose wheel follows the guide lines. However, where the precise alignment of aircraft on the stand is essential, secondary guide lines may be necessary. Secondary guide lines are also necessary when a large aircraft stand must accommodate more than one small aircraft at the same time (see Figure 2-8). Such stands are commonly known as superimposed stands. In all these cases, the primary line should be for the most critical aircraft, i.e. the aircraft requiring the greatest manoeuvring area.

Characteristics of guide lines

2.3.13 The guide lines should normally be continuous solid yellow lines at least 15 cm, but preferably 30 cm, in width. However, where a secondary guide line is provided, it should be a broken line to distinguish it from the primary line. Additionally, the type of aircraft that is to follow each line should be clearly indicated.

2.3.14 Where it is considered necessary to distinguish between lead-in lines and lead-out lines, arrow heads indicating the directions to be followed should be added to the lines. The designation number/letter of the stand should be incorporated in the lead-in line (see Figure 2-9). Additionally, a stand identification sign should be provided at the back of the stand, e.g. on the building or a pole, so as to be clearly visible from the cockpit of an aeroplane.

Reference bars

2.3.15 Examples of reference bars and their functions are:

- a) turn bar (indicates the point at which to begin a turn);
- b) stop line (indicates the point at which to stop); and

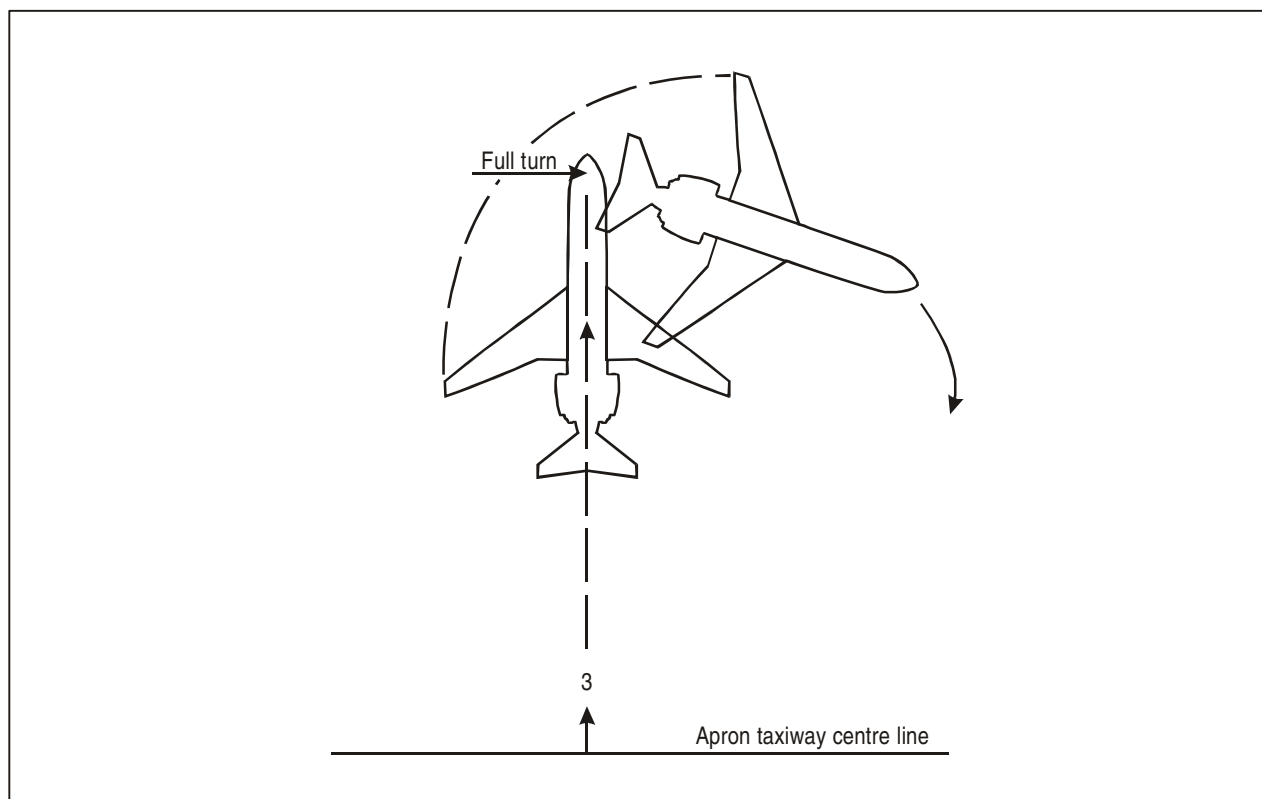

Figure 2-4. Straight lead-in line

- c) alignment bar (assists in aligning the aircraft on the desired angle).

Figure 2-9 shows an example of the use of a), b) and c).

2.3.16 Characteristics of reference bars. Turn bars or stop lines should be in the order of 6 m in length and not less than 15 cm in width and of the same colour as the guide line, i.e. yellow. They should be located to the left side of and at right angles to the guide lines abeam the pilot seat at the point of turn and stop. The turn bars may include an arrow and the words “FULL TURN” as in Figure 2-4. An alignment bar should be at least in the order of 15 m in length and 15 cm in width and be placed so as to be visible from the pilot seat.

2.3.17 Grouping of aircraft to reduce the number of turn bars and stop lines. Where an aircraft stand is meant to be used by several aeroplane types, it will be necessary to group them to reduce the number of turn bars and stop lines. There is, however, no agreed or widely used method for grouping aeroplanes. In the case of self-manoeuvring

stands, one can group aeroplanes that have similar turning capabilities and geometry; it is even possible to include smaller aeroplanes that might have dissimilarities provided that, in following the guide lines, they do not transgress the outline of the area needed by other types which dictate the stand clearances. For nose-in stands, one is perhaps less concerned with size and turning capability than with such factors as exit locations and the type of aerobridge or passenger gangway available. Where hydrant refuelling is installed, refuelling points must also be taken into account. One therefore needs to study the individual situation at each airport and tailor any grouping to facilities available, the mixture of aeroplane types and their numbers, apron layout, etc.

2.3.18 Coding system for turn bars and stop lines. Where an aircraft stand is used by two or three types of aircraft only, it is possible to indicate by a painted inscription the aircraft type for which each set of markings is intended. Where an aircraft stand is meant for several aircraft types, there may be a need to code the turn bars and stop lines to simplify the markings and to facilitate safe and

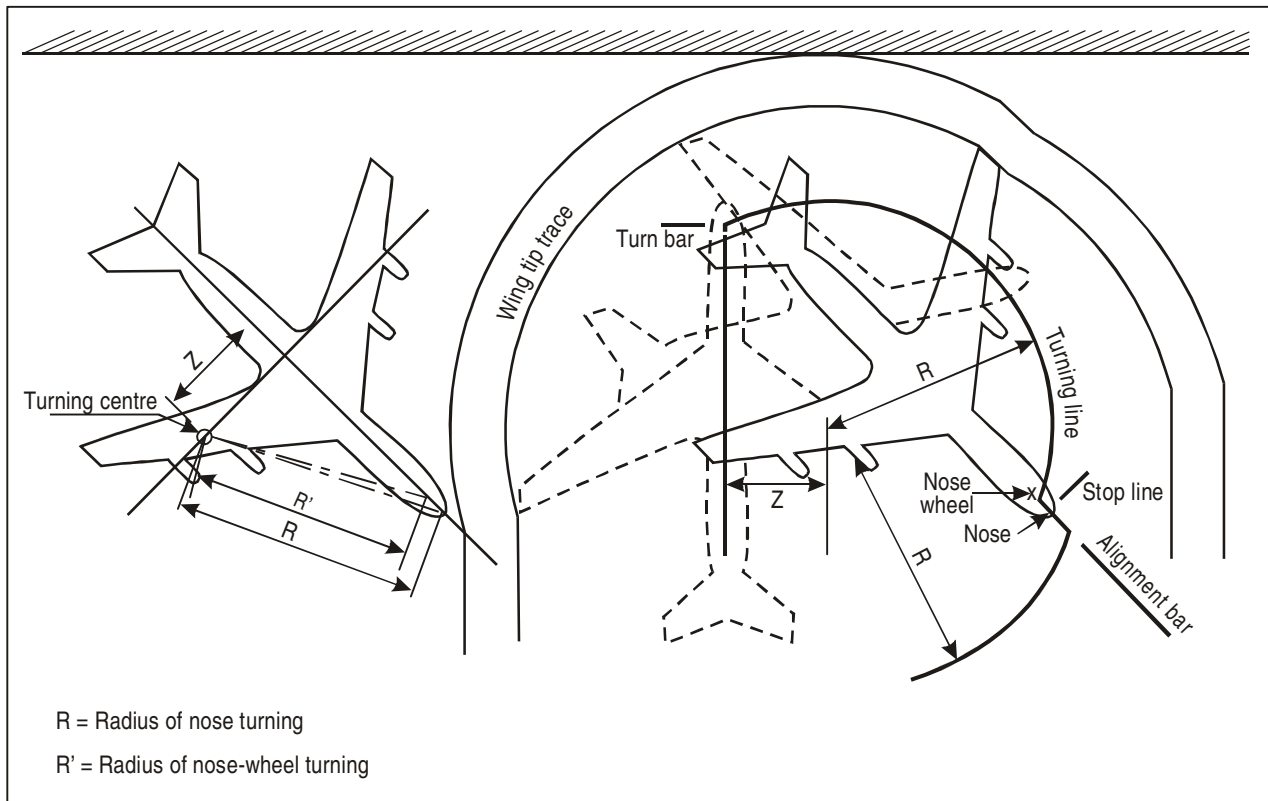

Figure 2-5. Turning line and reference bars

expeditious manoeuvring of aircraft. There is, however, no agreed or widely used coding system. The coding system adopted should be such that pilots can understand and use it without difficulty.

2.3.19 **Towing lines.** Where aircraft are to be towed, guide lines may be needed for the operator of the tractor to follow.

Apron safety lines

2.3.20 Safety lines will be required on an apron to mark the limits of parking areas for ground equipment, service roads and passengers' paths, etc. These lines are narrower and of a different colour to differentiate them from the guide lines used for aircraft.

2.3.21 **Wing tip clearance lines.** These lines should delineate the safety zone clear of the path of the critical

aircraft wing tip. The line should be drawn at the appropriate distance mentioned in 2.3.2 outside the normal path of the wing tip of the critical aircraft. The width of the line should be at least 10 cm.

2.3.22 **Equipment limit lines.** These lines are used to indicate the limits of areas which are intended for parking vehicles and aircraft servicing equipment when they are not in use. Several methods are currently in use to identify which side of a safety line is safe for storage of such vehicles and equipment. At some airports, the words "Equipment Limit" are painted on the side used by ground equipment and readable from that side. The height of the letters is about 30 cm. At others, spurs or an additional line (a discontinuous line of the same colour or a continuous line of a different colour) is provided on one side of the safety line. The side on which such spurs or an additional line is located is considered safe for parking vehicles and equipment.

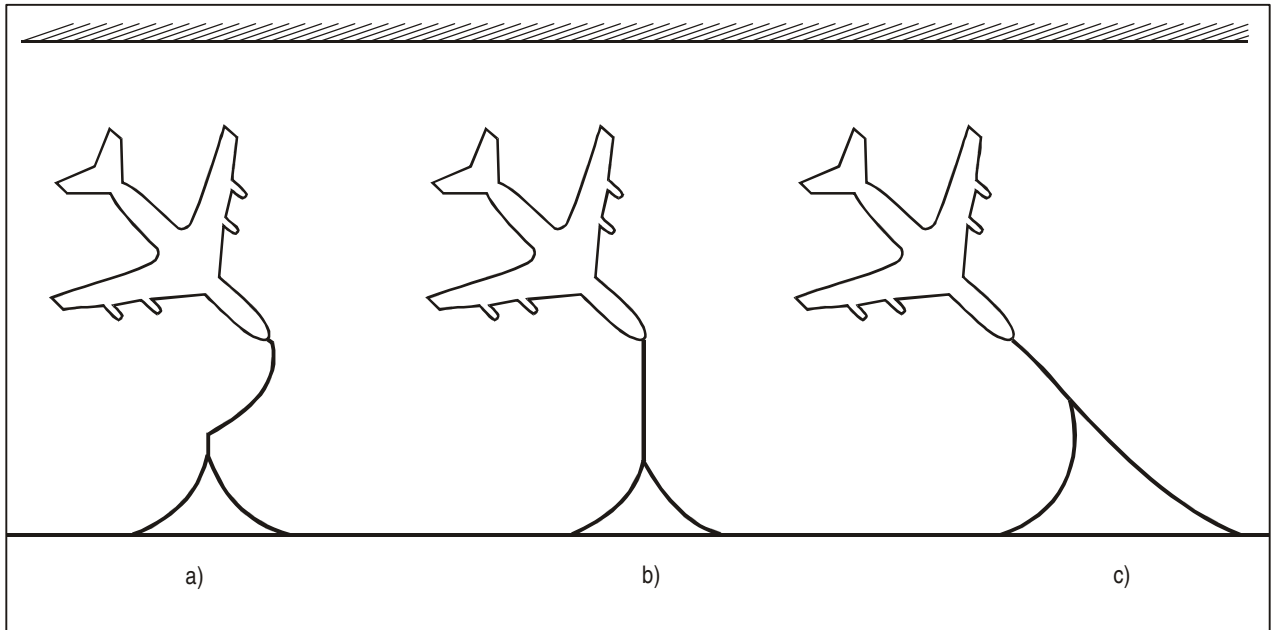

Figure 2-6. Simple nose-wheel lead-out lines

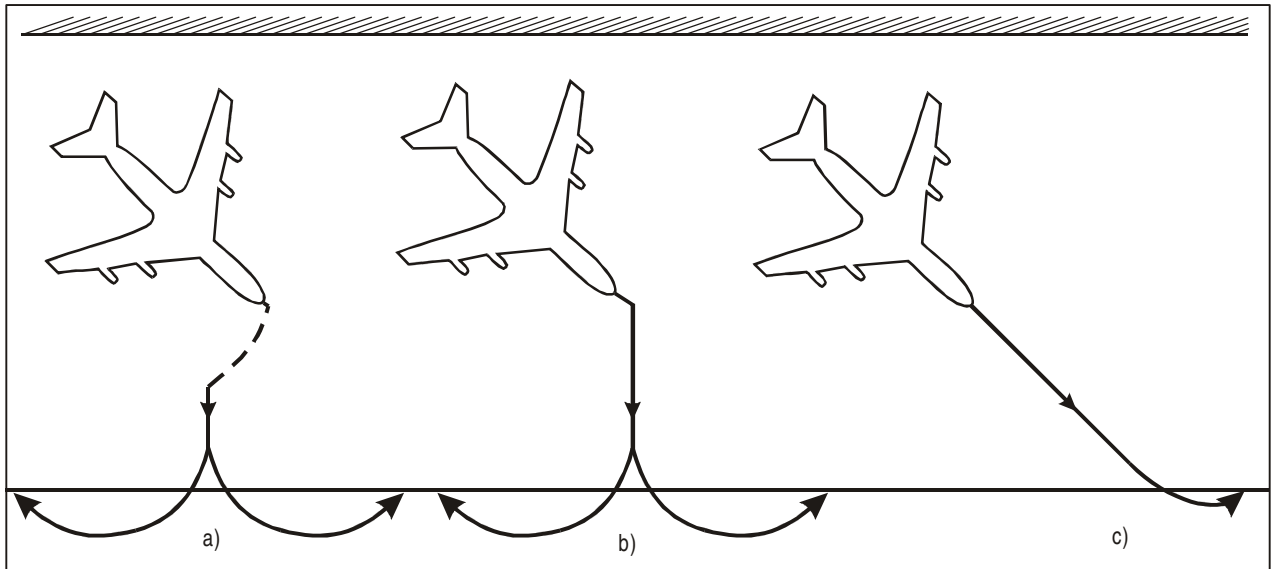

Figure 2-7. Offset nose-wheel lead-out lines

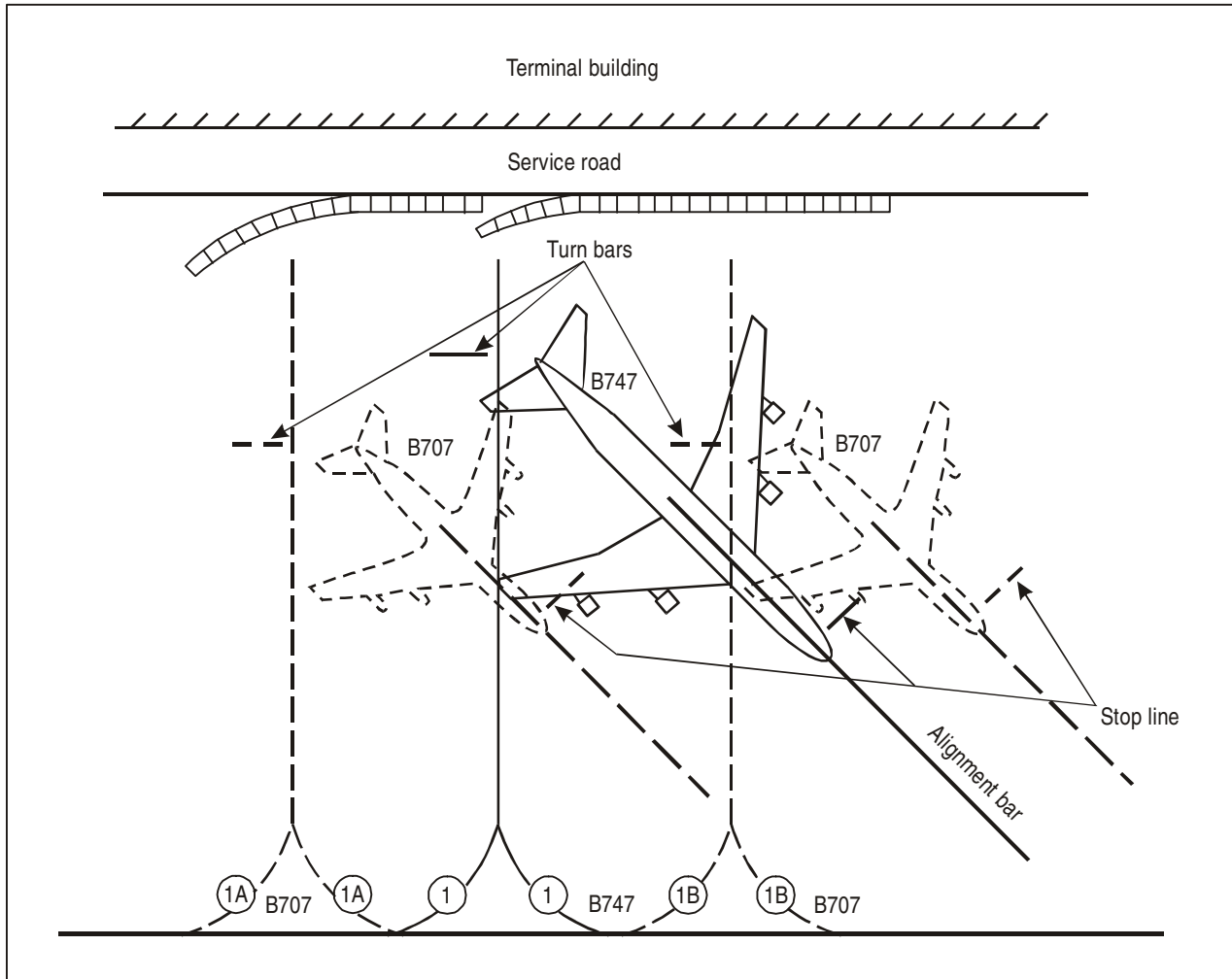
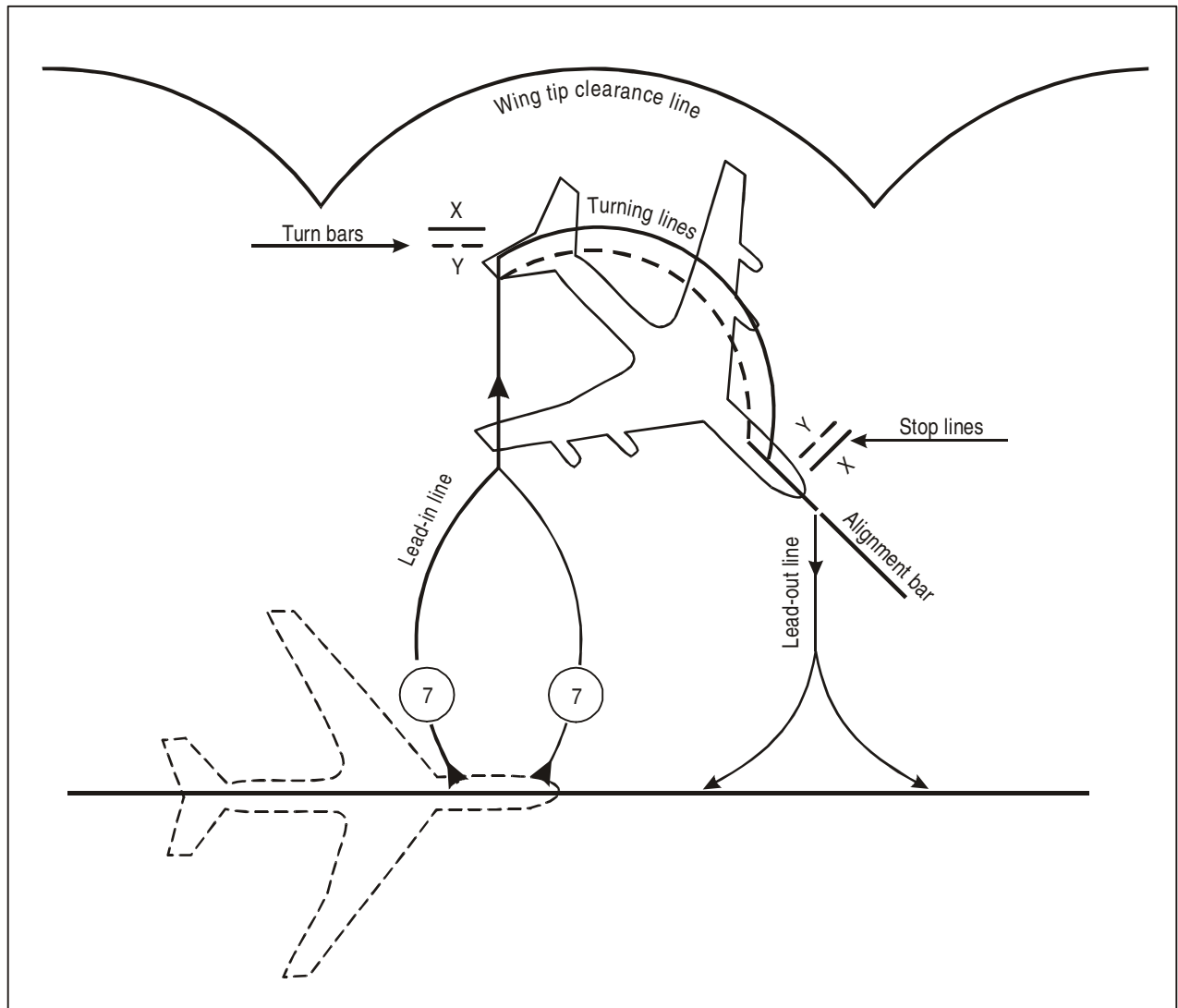

Figure 2-8. One method of marking superimposed stands



NOTES:

1. The number "7" is the aircraft stand number.
2. Solid lines and bars are for aircraft X and dotted lines and bars for aircraft Y.
3. Alignment bar is for all types of aircraft using the gate position.

Figure 2-9. Examples of reference bars

2.3.23 **Passenger path lines.** These lines are used to keep passengers, when walking on the apron, clear of hazards. A pair of lines with zebra hatching between them is commonly used.

2.4 TAXIWAY EDGE MARKERS

2.4.1 At small aerodromes, taxiway edge markers may be used, in lieu of taxiway edge lights, to delineate the edges of taxiways, particularly at night. Annex 14, Volume I, recommends the use of such markers on taxiways where the code number is 1 or 2 if taxiway centre line or taxiway edge lights are not present.

2.4.2 On a straight section of a taxiway, taxiway edge markers should be spaced at uniform longitudinal intervals of not more than 60 m. On a curve the markers should be spaced at intervals less than 60 m so that a clear indication of the curve is provided. The markers should be located as near as practicable to the edges of the taxiway, or outside the edges at a distance of not more than 3 m.

2.4.3 A taxiway edge marker shall be retro-reflective blue conforming to the specifications in Appendix 1 of

Annex 14, Volume I. The marked surface as seen by the pilot should be a rectangle and have a minimum viewing area of 150 cm².

Note.— The performance of retro-reflective materials is sensitive to the geometry of the illumination source and the viewpoint of the pilot. The performance is optimized when the taxi-light on an aircraft is located close to the position of the pilot.

2.4.4 The markers commonly used are cylindrical in shape. Ideally, the design of the marker should be such that, when installed properly, no portion will exceed 35 cm total height above the mounting surface. However, where significant snow heights are possible, markers exceeding 35 cm in height may be used, but their total height should be sufficiently low to preserve clearance for propellers and for the engine pods of jet aircraft.

2.4.5 A taxiway edge marker shall be lightweight and frangible. One type of marker meeting these requirements is detailed in Figure 2-10. The post is made up of flexible PVC and its colour is blue. The sleeve, which is retro-reflective, is also blue. Note that the area of the marked surface is 150 cm².

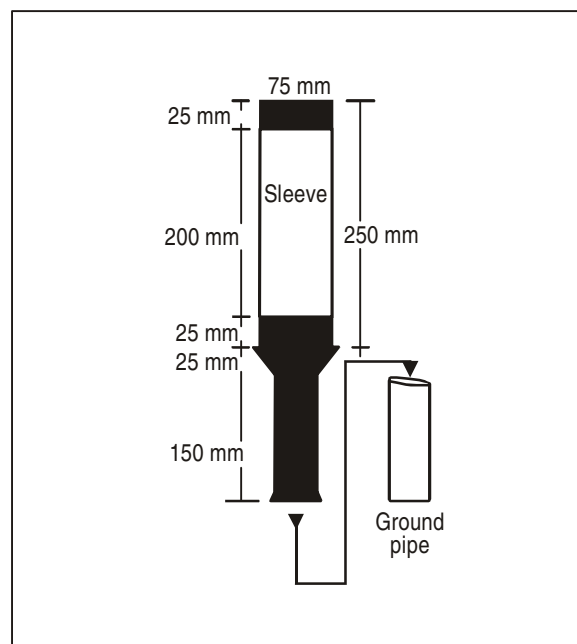

Figure 2-10. Taxiway edge marker

Chapter 3

Signal Area and Panels

3.1 GENERAL

3.1.1 A signal area need only be provided when it is intended to use visual ground signals to communicate with aircraft in flight. Such signals may be needed when the aerodrome does not have an aerodrome control tower or an aerodrome flight information service unit, or when the aerodrome is used by aeroplanes not equipped with a radio. Visual ground signals may also be useful in the case of failure of two-way radio communication with aircraft. It should be recognized, however, that the type of information which may be conveyed by visual ground signals should normally be available in AIPs or NOTAM. The potential need for visual ground signals should therefore be evaluated before deciding to provide a signal area.

3.1.2 Annex 2, Chapter 4, includes specifications on ten different types of visual ground signals which cover such aspects as the shape, colour(s), location and purpose of each signal. Additionally, Annex 14, Volume I, Chapter 5, includes detailed specifications on the landing direction indicator and the signal area. The following paragraphs explain briefly how the signal area, the signal panels and the landing “T” should be constructed.

3.2 DESIGN

Signal area

3.2.1 The signal area should be an even horizontal surface at least 9 m square. It should be constructed of cement concrete reinforced with an adequate quantity of steel to avoid cracks resulting from unequal settlement. The top surface should be finished smooth with a steel trowel and coated with paint of appropriate colour. The colour of the signal area should be chosen to contrast with the colours of the signal panels to be displayed thereon. The signal area should be surrounded by a white border not less than 0.3 m wide.

Signal panels and landing “T”

Dumb-bell

3.2.2 This signal should be constructed of wood or other light material. The dumb-bell should consist of two circles 1.5 m in diameter connected by a crossbar 1.5 m long by 0.4 m wide as shown in Figure 3-1A. It should be painted white.

Landing “T”

3.2.3 The landing “T” should be constructed of wood or other light material and its dimensions should correspond to those shown in Figure 3-1B. It should be painted white or orange. The landing “T” should be mounted on a cement concrete pedestal adequately reinforced with steel bars to avoid cracks resulting from unequal settlement. The surface of the pedestal should be finished smooth with a steel trowel and coated with paint of appropriate colour. The colour of the pedestal should be chosen to contrast with the colour of the landing “T”. Before fastening the landing “T” base to the concrete pedestal, the mounting bolts should be checked for correct spacing. The landing “T” should be assembled and mounted in accordance with the manufacturer’s installation instructions. It should be free to move about a vertical axis so that it can be set in any direction. The under surface of the landing “T”, when mounted on its pedestal, should be not less than 1.25 m above ground level. Where required for use at night, the landing “T” should either be illuminated or outlined by white lights.

Red square with yellow cross

3.2.4 The dimensions of this signal panel, which relates to prohibition of landing, should correspond to those shown in Figure 3-1C. The signal panel can be constructed using a 3 m × 3 m galvanized iron sheet. The yellow cross should first be painted and then the remaining area should be painted red. The signal panel should be provided with at least two handles to facilitate handling.

Red square with yellow diagonal

3.2.5 This signal panel, which is shown in Figure 3-1D, should be constructed generally following the principles explained in the preceding paragraph. The only difference is that the signal panel will show a yellow diagonal in lieu of the yellow cross.

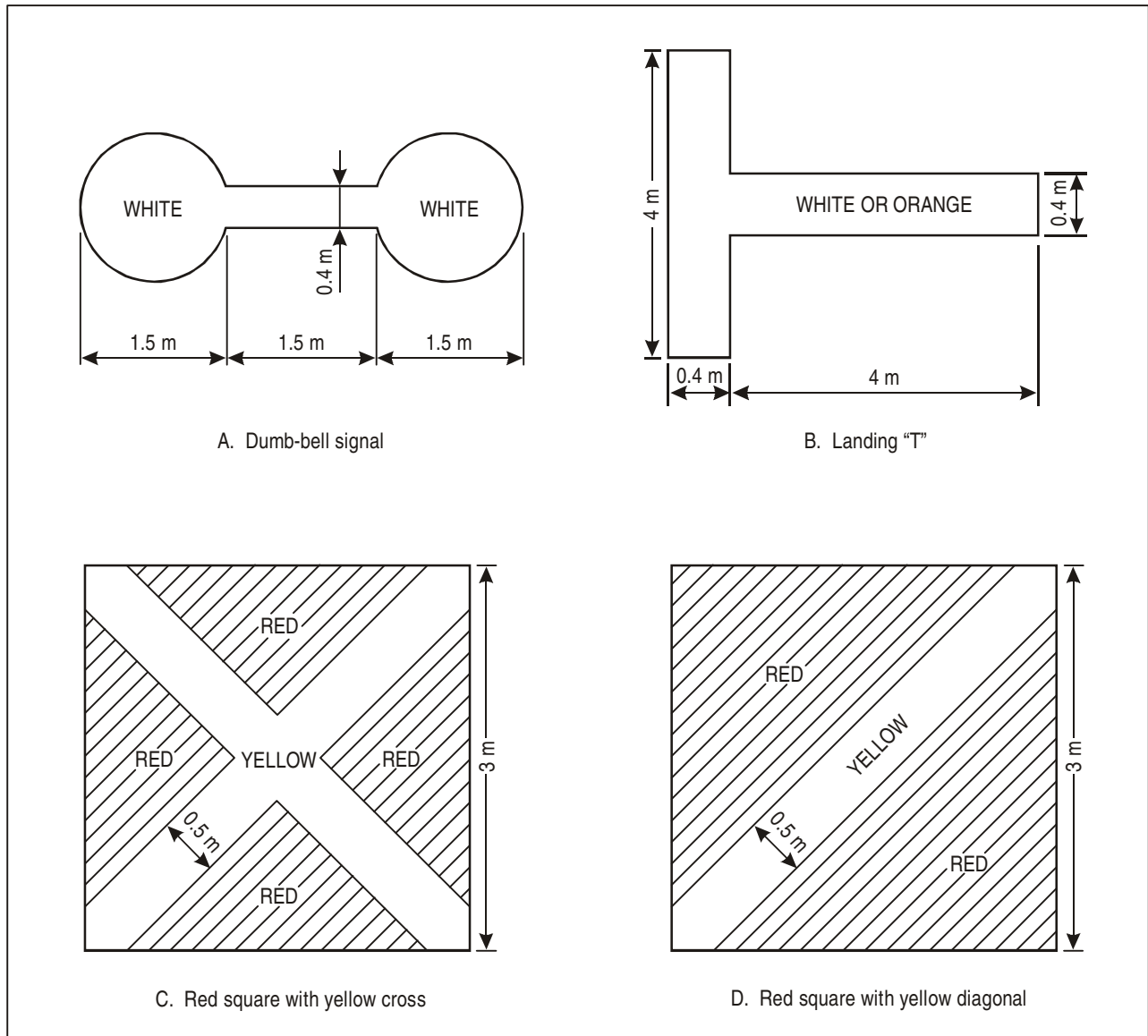

Figure 3-1. Signal panels and landing "T"

Chapter 4

Light Characteristics for Runways and Taxiways Used in Low Visibility Conditions

4.1 FACTORS DETERMINING REQUIRED LIGHT DISTRIBUTION

The required light distribution is dependent on four main factors. These are:

- a) the extent to which the aircraft may be expected to deviate from its nominal or ideal flight path during its approach for landing. Such deviations are contained within what is called the “flight path envelope”;
- b) the range of “eye-to-wheel” and “eye-to-aerial” heights of aircraft for current and planned operations;
- c) the distance up to which the lights must be visible at any particular stage of the approach, touchdown, roll-out, take-off and taxiing phases and the visibility conditions in which the lights must provide guidance;
- d) the available downward view in front of the aircraft; and
- e) the extent to which the aircraft may be expected to deviate from the taxiway centre line when taxiing.

4.2 FLIGHT PATH ENVELOPES

Categories I and II

4.2.1 Flight path envelopes used in designing the lighting for approaches and the ground roll on the runway are shown in Figure A-4 of Attachment A to Annex 14, Volume I. They are based on 99 per cent isoprobability values from Obstacle Clearance Panel (OCP) data for points at distances of 600 m and 1 200 m from the runway threshold.

4.2.2 The upper boundaries take into account the height of the pilot’s eyes above the ILS/MLS receiver

antenna on the aircraft. The Category I and II boundaries based on these data have been terminated at the respective minimum decision heights, i.e. 60 m and 30 m respectively. Below these heights the flight envelopes are defined by the limits of the flight paths which would result in a satisfactory landing in visual conditions. The lower boundary of the Category I envelope has been set at two degrees elevation with an origin at the outermost approach light to cater for non-precision approaches in good visibilities.

Category III

4.2.3 At the time when the flight path envelopes were defined, there were insufficient Category III flight data available on which to base Category III flight envelopes. The vertical boundaries shown in Figure A-4 of Attachment A to Annex 14, Volume I, are those derived for Category II boundaries, truncated at an upper decision height limit of 30 m, which would generally be associated with the upper runway visual range (RVR) value of 350 m. In the horizontal plane the lateral offset limit at touchdown is 10 m either side of the runway centre line. At a height of 30 m the aircraft should be within the width of the runway; this point on the lower boundary is taken as the starting point of the lateral boundary.

4.3 OPERATIONAL REQUIREMENTS AND ASSUMPTIONS

Category I

4.3.1 In Category I operating conditions, the runway and approach lighting systems must be effective not only at the limiting RVR of 550 m but also in intermediate and good visibilities.

Category II

4.3.2 In Category II operating conditions, i.e. 550 m to 350 m RVR, red side row barrettes are provided to

supplement the lateral and longitudinal position information available from the inner 300 m of the approach lighting system, touchdown zone lights are provided to enhance surface textural cues during the flare manoeuvre and runway centre line lights are installed to improve steering guidance during the ground roll and during take-offs in this range of visibilities.

Category III

4.3.3 In Category III operating conditions, the same visual guidance as provided for Category II conditions is required for taxiing, take-off, landing and roll-out. This guidance is required in visibilities down to the lower limit of Category IIIB, i.e. 50 m RVR.

4.4 OPERATING PROCEDURES IN RVR LESS THAN 350 M

Taxiing

4.4.1 Pilots taxiing aircraft in low visibility conditions are guided by visual reference to medium/high-intensity green centre line taxiway lights. In these conditions the “see-and-be-seen” principle will not always be effective in maintaining safe separation between aircraft. To safeguard aircraft approaching taxiway and runway intersections and to prevent taxiing aircraft from infringing on ILS/MLS critical/sensitive areas while other aircraft are approaching to land, stop bars are needed to regulate aircraft at recognized holding points. More details are given in Chapter 10.

Take-off

4.4.2 The runway centre line lights and markings are the primary visual cues used by the pilot to provide directional guidance until the aircraft is rotated. (Runway edge lights have a role in take-off or landing if the aircraft starts to deviate significantly from the runway centre line.) From this point the pilot completes the take-off by reference to flight instruments. If the take-off is abandoned before rotation speed is reached, the pilot continues to refer to the centre line lights and markings until the aircraft is brought to rest, or taxied from the runway.

Landings

4.4.3 In all Category III operations the non-visual guidance systems are designed to deliver the landing

aircraft to a position over the runway from which a safe landing can be made. If the aircraft is not delivered to the prescribed position in space within closely defined limits, then the missed approach procedure is initiated. Landings in Category IIIA conditions are made when the pilot is satisfied, by reference to the runway lights or markings, that the aircraft’s position is within the overall width of the touchdown zone and that the aircraft is tracking satisfactorily in azimuth. The pilot must assess whether or not the visual segment of the runway centre line lighting is sufficient to enable manual completion of the roll-out. In the higher visibilities of Category IIIA, some benefit may be derived from the inner 300 m of approach lighting because the pilot will be able to assess position and track relative to the runway centre line before crossing the threshold. For operations in Category IIIB minima, the approach, flare and initial roll-out are entirely automatic. The pilot transfers to visual cues to identify the turnoff from the runway and then to follow the taxiway centre line lighting systems.

4.5 ANALYSIS OF LIGHTING DESIGN

4.5.1 In deriving the light characteristics shown in Annex 14, Volume I, Appendix 2, Figures 2.1 to 2.10, the following principles and procedures have been applied:

- a) the fog is of uniform density;
- b) the overall lighting system should be balanced in the sense that the visual segment seen by the pilot generally increases continuously; and
- c) for a given meteorological visibility, the length of the visual segment seen after initial contact should be the same for all approach paths within the approach envelopes.

4.5.2 Aircraft are assumed to follow the boundaries defined in Figure A-4 of Attachment A to Annex 14, Volume I. The visual range, the elevation angles and the azimuth angle between the aircraft and representative light positions in the approach and runway lighting patterns at positions along the boundaries are calculated for a number of values of visual segment.

4.5.3 The corresponding values of the intensity needed to meet the visual range requirement are calculated for each case, using Allard’s Law, for a range of values of the equivalent meteorological visibility appropriate to the three ICAO categories of low visibility operation for daylight values of the pilot’s illuminance threshold (10^{-4} to 10^{-3} lux).

4.5.4 The above calculations are repeated for various aircraft types using appropriate values of the cockpit cut-off angle (the distance ahead of the aircraft that is obscured from the pilot by the cockpit and nose of the aircraft; Figure 4-1 refers) and aircraft dimensions pertaining to the ILS/MLS receiver aerial-to-eye height during the approach and the wheel-to-eye height during the ground-roll. The resulting information is plotted to give the theoretical angular distribution of luminous intensity required for that light in the pattern. Computer modelling techniques are the best means of developing these specifications.

Alignment and manufacturing tolerances

4.5.5 In general, elevated lights are more prone to misalignment during service, while inset lights demand very accurate alignment during initial installation because subsequent correction is difficult to achieve. The variations from the norm clearly depend upon, among other things, the quality of design, construction and maintenance, but are unlikely to be more than one degree. Consequently, a tolerance of one degree should be added to each side of the angles in Annex 14, Volume I, Appendix 2, Figures 2.1 to 2.10, when specifying the output characteristics of the fittings. Furthermore, when manufacturing light fittings, it is important that the specified tolerances be followed to ensure that all fittings meet the specification. If lights are not manufactured and aligned to the specified tolerances, lighting patterns will give inconsistent visual segments.

4.5.6 During the design and assessment of the lighting specified in Annex 14, Volume I, Appendix 2, Figures 2.1 to 2.10, it was assumed that the reference point for the designation of setting angles would be the geometric centre of the inner (main beam) ellipse. It was also assumed that the light distribution within the main beam would be symmetrical about the beam centre and that using the measurement grid shown in Figure 2.11 the highest intensity would occur within one degree of the geometric beam centre. Light units not conforming to these design assumptions may result in significant discontinuities in the guidance provided to pilots.

4.6 LIGHTING SPECIFICATIONS

General

4.6.1 Annex 14, Volume I, Appendix 2, Figures 2.1 to 2.10, show isocandela diagrams, toe-in values (where

appropriate) and setting angles (where appropriate) for a lighting system design suitable for use on all categories (i.e. I, II or III) of precision approach runways. The isocandela curves are ellipses computed from the equation $(x^2/a^2) + (y^2/b^2) = 1$ where the values of a and b are one-half of the horizontal and vertical beam spreads respectively. In plotting these curves, the axis of the beams has been used as the origin, and setting angles are not included. Intensities are indicated for the specified colour of the light except that white only is shown for runway edge and centre line lights. The specified intensities are the required in-service values to meet operational criteria. Lighting systems should therefore be designed so that when they are installed they are capable of providing the light outputs shown in Annex 14, Volume I, Appendix 2, Figures 2.1 to 2.10. The intensities specified are the minimum values applicable to all newly manufactured light units, and the maintenance objective should be to maintain these intensities in service. Reference is made to Chapter 17.

4.6.2 The lights shown in Annex 14, Volume I, Appendix 2, Figures 2.1 to 2.10, have been designed to support all landing operations down to approximately 75 m RVR for aircraft coupled accurately to an appropriate precision ILS/MLS. They will also provide guidance for manual approaches using low accuracy instrument approach aids. For take-off, these lights will provide adequate guidance down to approximately 100 m RVR.

4.6.3 Annex 14, Volume I, Appendix 2, Figures 2.12 to 2.14, list the intensity and beam coverage required of taxiway centre line lights for taxiways intended for use in RVR conditions less than a value of the order of 350 m. These lights will provide adequate guidance down to approximately 100 m RVR.

4.6.4 Annex 14, Volume I, Appendix 2, Figures 2.15 and 2.16, list the intensity and beam coverage required of taxiway centre line lights for taxiways intended for use in RVR conditions of the order of 350 m or greater.

4.6.5 The intensity and beam coverage shown in Annex 14, Volume I, Appendix 2, Figures 2.17 to 2.19, are specified for use in advanced surface movement, guidance and control systems (A-SMGCS) and where, from an operational point of view, higher intensities are required to maintain ground movements at a certain speed in very low visibilities or in bright daytime conditions. The circumstances where this lighting would be used should be established by a specific study. For example, such a study may show that lighting conforming to Figures 2.12 to 2.14 will not allow the pilot to see enough lights to continuously

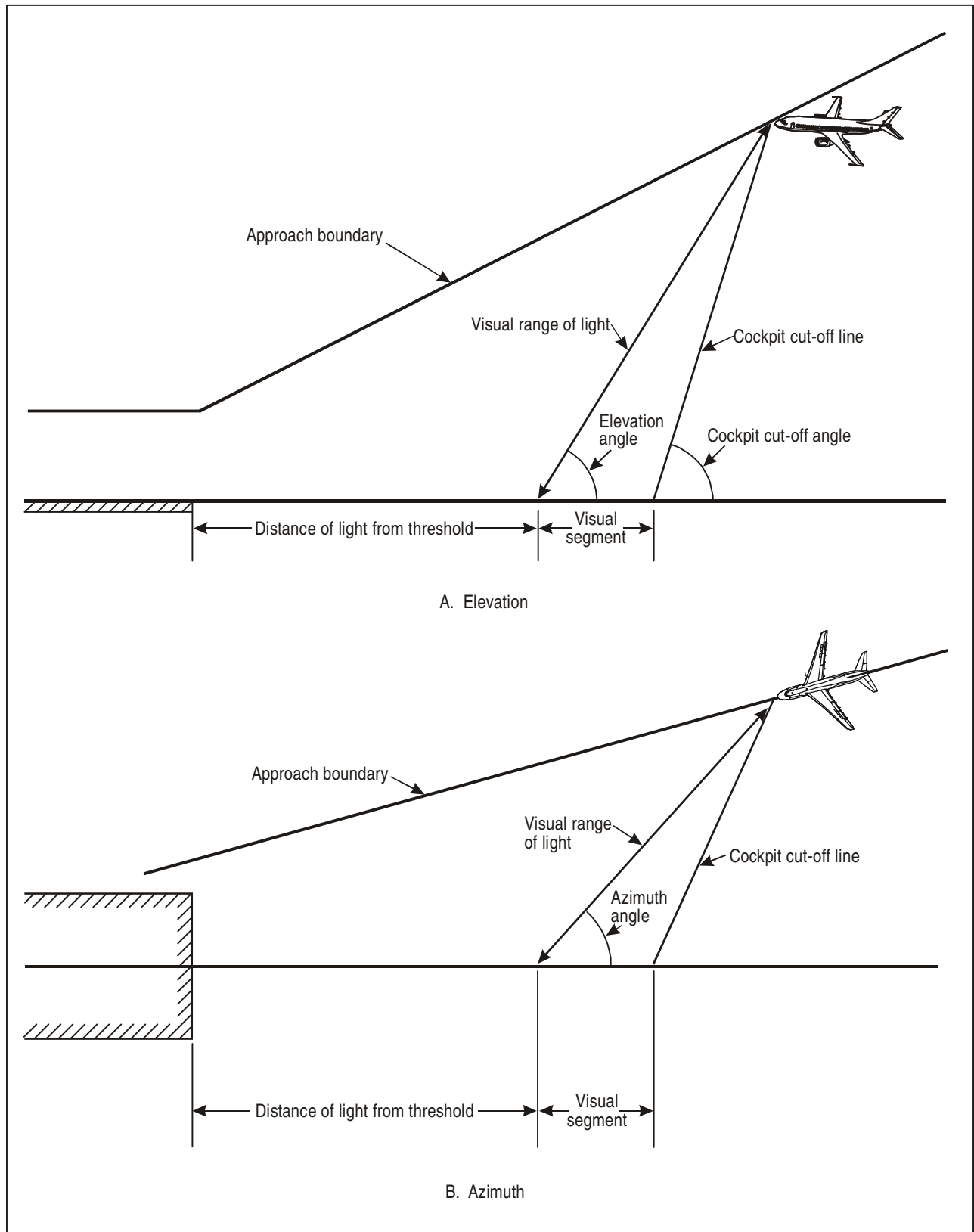

Figure 4-1. Visual segment geometry

maintain the aircraft on the assigned route in the conditions described above. The pilot may not be able to see a sufficient number of lights because of the density of the thickest fog in which operations are planned to take place or because the extent of the view that is obscured immediately ahead of the aircraft (cockpit cut-off) is large.

Taxiway centre line lights

4.6.6 RVRs of the order of 350 m or greater. For operations in such visibilities, taxiway lights are generally used to provide steering information as opposed to indicating the selection of a particular route. For daytime operations, taxiway lights are not necessary. At night, intensities of 20 cd in green light are adequate. This can easily be achieved omnidirectionally as well as by the lights specified in Annex 14, Volume I, Appendix 2, Figures 2.15 and 2.16. For difficult locations (such as high brightness background and variable density fog conditions), a minimum average intensity of 50 cd may be needed.

4.6.7 RVRs less than a value of the order of 350 m. Operational experience and simulator trials have shown that aircraft can be manoeuvred safely along a taxiway which has the centre line defined by lights when the pilot can see a visual segment of the order of 50 m. Within such a segment, the position of the centre line can be adequately perceived by a minimum of three lights, spaced at 15 m intervals. Thus, the distance of the furthest perceived light from the pilot will be 45 m, plus the distance ahead of the aircraft that is obscured from the pilot by the cockpit and nose of the aircraft.

4.6.8 For straight sections of taxiway, the azimuth beam coverage is comparatively easy to define. It is necessary only to provide sufficient lighting to allow the pilot to taxi on or near the centre line.

4.6.9 Various methods of steering large aircraft around curves are currently practised. The preferred method requires the pilot to steer the aircraft, keeping the cockpit continuously over the taxiway centre line. This technique requires the construction of fillets on the inner edges of the curves and at intersections since the main wheels of the aircraft will track well inside the path of the nose wheel. In an alternative method, the pilot endeavours to keep the aircraft's nose wheel tracking along the taxiway centre line. On large aircraft where the cockpit is considerably ahead of the nose wheel, the pilot's position will trace a path well outside the centre line of all curves, and fillets may still be necessary.

4.6.10 The requirements for taxiway centre line lighting specified in Annex 14, Volume I, Appendix 2, are based upon the cockpit over centre line tracking technique, which follows the recommendation of Annex 14, Volume I, Chapter 3. Where other techniques are used, wider horizontal beam coverage will be required to extend the light coverage substantially outside the tangent to the curve.

4.6.11 For curves and intersections having radii of less than 400 m, the standard spacing of lights should be half the spacing of the straight sections. (The radius of most curves is less than 200 m.) Radii greater than 400 m normally occur in special circumstances, for example, fast turnoffs from runways, where the radius is so large that straight section spacings are suitable. The requirement for operations in RVRs less than a value of the order of 350 m is, therefore, that the spacing of the lights for straight sections of the taxiway is 15 m and that on and near curves a standard spacing of 7.5 m should be adopted.

4.6.12 Experience has shown that the closer spacing of lights before a curve gives adequate warning of an imminent change in direction to pilots taxiing in low visibilities and thus allows them to adjust their speed in anticipation. Closer light spacing should be provided up to a minimum distance of 60 m before the start of the curve.

4.6.13 Aircraft using the cockpit or nose-wheel tracking techniques may emerge from a curve with a large heading error relative to the taxiway centre line. Thus, in order to accommodate low visibility operations, it is desirable to continue closer spacing of lights a similar distance of 60 m after the curve. This assists the pilot in realigning the aircraft and gives a smooth lead-in to the greater spacing of the straight section fittings.

4.6.14 The azimuth beam coverage for lights on curves is governed by the requirement to:

- a) maintain a minimum segment of three lights beyond the cockpit cut-off;
- b) provide information on the rate of change of direction of the curve;
- c) indicate the magnitude of any displacement of the aircraft from the taxiway centre line; and
- d) operate normally in both directions of travel.

4.6.15 Figure 4-2 illustrates how to calculate the beam coverage required of a centre line light on a bend,

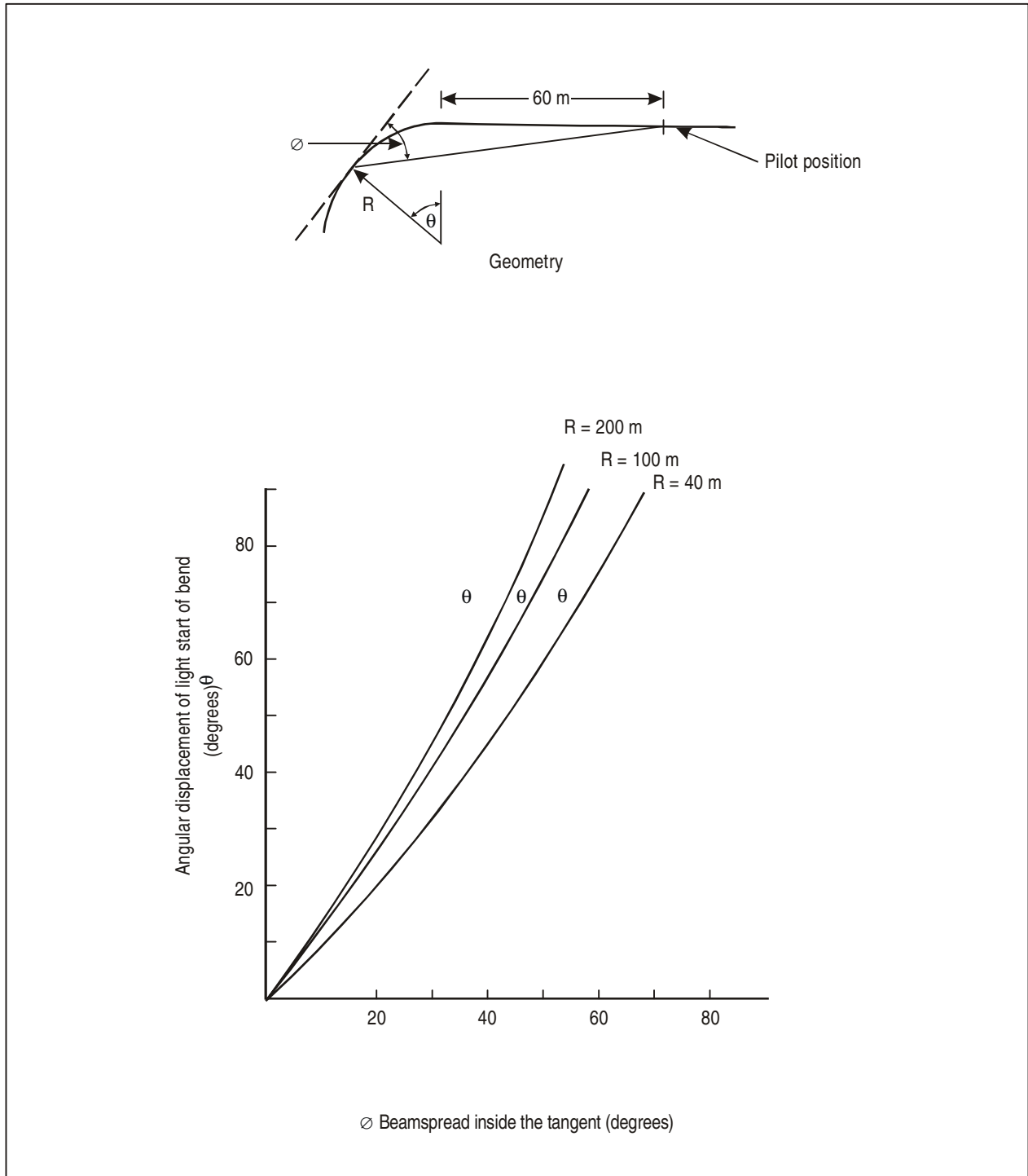

Figure 4-2. Taxiway lighting geometry

using a pilot position of 60 m from the bend as an example. The figure shows the relationship between the position of the light on the bend, the azimuth beam coverage required (ϕ) and the radius of the bend (R). It also shows that small radius curves will define the requirements since they need the widest beam coverage. If all the curve must be visible, then $\theta = 90$ degrees; for a curve radius of 40 m, the beam coverage required is 68 degrees. If θ is reduced to 60 degrees (2/3 of the bend), then the beam coverage inside the bend should be 50 degrees. A 3-degree coverage is required outside the tangent to the curve since, in practice, the cockpit will not track the centre line precisely. For an aircraft operating in RVRs less than a value of the order of 400 m when only three lights may be seen from the start of the bend, the beam coverage inside the tangent should be 35 degrees, but this will not be the optimum value for RVRs greater than 400 m. At airports where there is a complex taxiway system, the requirements at those intersections where several taxiway routes converge may be met by multiple installation of restricted beam width fittings.

4.6.16 Lights with similar beam coverage should be retained for a distance of 60 m beyond the curve; otherwise, the visual segment will decrease as the aircraft progresses around the curve. In low visibilities this could result in there being fewer than three lights visible to the pilot at a spacing of 7.5 m.

4.6.17 **Stop bars.** The intensity and beam coverage of the lights should not be less than those specified in Annex 14, Volume I, Appendix 2, Figures 2.12 to 2.16, as appropriate.

4.6.18 Where higher intensities are required to enhance the conspicuity of lights or increase the visual range of the lights, particularly where the lighting forms part of an advanced surface movement guidance and control system, the specifications shown in Annex 14, Volume I, Appendix 2, Figures 2.17 to 2.19, should be used. The circumstances where this lighting would be used should be established by a specific study.

Chapter 5

Light Intensity Settings

5.1 Light intensity settings for different visibility ranges (day conditions) are given in Table 5-1. The intensities specified apply to the main beam dimensions recommended in Annex 14, Volume I, Appendix 2, Figures 2.1 to 2.10. Background luminances are between 1 000 cd to 40 000 cd per square metre. During conditions of bright day (background luminance more than 40 000 cd per square metre, exemplified by sunlit fog), the maximum intensity settings should always be used. Although the maximum is normally used during the day, it is the practice in some States, when conditions permit, to use a lower setting because the lamp life is greatly lengthened when lamps are operated at a reduced intensity.

5.2 Table 5-3 specifies light intensity settings for different visibility ranges (night conditions). The intensities specified apply, even though they differ from the main beam dimensions recommended in Annex 14, Volume I, Appendix 2, Figures 2.1 to 2.10. According to Annex 3, Attachment D, the background luminances at standard night (to be used for RVR calculations from transmissometer readings) are defined as 4 cd to 50 cd per square metre. However, measurements at several airfields have shown that at the currently recommended intensity settings, background luminances are lower than 15 cd per square metre.

In good visibility and outside urban areas, background luminances may even be in the order of 0.1 cd per square metre or lower; under these conditions, the lowest intensity settings (column 6) might be found useful.

5.3 Whereas Table 5-1 was developed on the basis of well-established practices, Table 5-3 is based on theoretical considerations combined with experience from flight trials. For each visibility condition, a range of intensity settings is presented. It is recommended that States adapt their intensity setting procedures such that the values and especially the lighting intensity ratios given in Table 5-3 are followed as closely as possible to provide balanced lighting intensities.

5.4 Table 5-2 specifies light intensity settings for dawn and dusk conditions (twilight). It is based on the assumption that the required settings are to be identified at values that lie between the values shown in Tables 5-1 and 5-3.

5.5 Figures 5-1 to 5-3 present the data given in Tables 5-1 to 5-3 in graphical form. Each figure combines the appropriate data for each type of light. Information on the method used to develop this graphical presentation is given in Appendix 5.

**Table 5-1. Light intensity adjustments for day conditions
(background luminance = 1 000 cd/m² to 40 000 cd/m²)**

Lighting system	Runway visual range ^a or visibility			
	RVR ≤ 800 m (Notes b & c)	RVR 800 m to RVR 1 500 m (Notes b & d)	RVR 1 500 to vis 5 000 m (Note e)	Vis ≥ 5 000 m (Note f)
Approach centre line and crossbars	20 000	20 000	10 000	–
Approach side row	5 000	5 000 ^g	2 500 ^g	–
Touchdown zone	5 000	5 000 ^{g/h}	2 500 ^g	–
Runway centre line	5 000 ^h	5 000 ^g	2 500 ^g	–
Threshold and wing bar	10 000	10 000	5 000	–
Runway end	2 500	2 500	2 500	–
Runway edge	10 000	10 000	5 000	–

NOTES:

- a. For the purposes of developing this table, it is assumed that RVR values are based on an intensity of 10 000 cd and a background luminance of 10 000 cd/m². Where RVR measurement is not available, meteorological visibility will apply.
- b. For RVR values less than 1 500 m, the intensity setting selected should provide the balanced lighting system required by Annex 14, Volume I, 5.3.1.10.
- c. When the RVR is less than 400 m or when the background luminance is greater than 10 000 cd/m², higher intensities would be beneficial operationally.
- d. When the background luminance is less than 10 000 cd/m², an intensity half of those specified may be used.
- e. These intensities are to be used for approaches into low sun.
- f. At visibilities greater than 5 km, lighting may be provided at the pilot's request.
- g. Where these intensities cannot be achieved, the maximum intensity setting should be provided.
- h. The provision and operation of these lights are optional for these visibilities.

**Table 5-2. Light intensity adjustments for twilight conditions^a
(background luminance = 15 cd/m² to 1 000 cd/m²)**

Lighting system	Runway visual range ^a or visibility				
	RVR ≤ 800 m	RVR 800 m to RVR 1 500 m	RVR 1 500 to vis 5 000 m	RVR 5 000 to vis 8 000 m	Vis ≥ 8 000 m
Approach centre line and crossbars	5 000–10 000	3 000–6 000	1 500–3 000	500–1 000	150–300
Approach side row	1 000–2 000	500–1 000 ^c	250–500 ^c	100–200 ^c	–
Touchdown zone	1 000–2 000	500–1 000 ^c	250–500 ^c	100–200 ^c	–
Runway centre line	1 000–2 000	500–1 000 ^c	250–500 ^c	100–200 ^c	–
Threshold and wing bar	2 500–5 000	1 500–3 000	750–1 500	250–500	75–150
Runway end	2 500	1 500–2 500	750–1 500	250–500	75–150
Runway edge	2 500–5 000	1 500–3 000	750–1 500	250–500	75–150

NOTES:

- a. To ensure that the values adopted for the different elements of the approach and runway lighting system are balanced, the intensity settings of the lighting systems should be uniformly in one part of the tolerance ranges shown, i.e. towards the top, the centre or the bottom.
- b. For the purposes of developing this table, it is assumed that RVR values are based on an intensity of 5 000 cd and a background luminance of 200 cd/m². Where RVR measurement is not available, meteorological visibility will apply.
- c. Where provided, these lights are to be operated at the intensities shown; however, their provision is optional for these visibilities.
- d. Where these intensity settings cannot be achieved, the maximum intensity setting should be provided.

Table 5-3. Light intensity adjustments for night conditions^a
(background luminance = 15 cd/m²)

Lighting system	Runway visual range ^a or visibility				
	RVR ≤ 800 m	RVR 800 m to RVR 1 500 m	RVR 1 500 to vis 5 000 m	RVR 5 000 to vis 8 000 m	Vis ≥ 8 000 m
Approach centre line and crossbars	1 000–2 000	600–1 200	300–600	100–200	50–100
Approach side row	250–500	150–300 ^c	100–150 ^c	25–40 ^c	–
Touchdown zone	200–500	150–300 ^c	100–150 ^c	25–40 ^c	10–20 ^c
Runway centre line (30 m)	200–500 ^d	150–300 ^c	100–150 ^c	25–40 ^c	10–20 ^c
Runway centre line (15 m)	200–500 ^d	150–300 ^c	100–150 ^c	25–40 ^c	10–20 ^c
Runway centre line (7.5 m)	200–500 ^d	150–300 ^c	100–150 ^c	25–40 ^c	10–20 ^c
Threshold and wing bar	1 000–2 000	600–1 200	300–600	100–200	20–40 ^c
Runway end	1 000–2 000	600–1 200	300–600	100–200	20–40
Runway edge	1 000–2 000	600–1 200	300–600	100–200	20–40

NOTES:

- To ensure that the values adopted for the different elements of the approach and runway lighting system are balanced, the intensity settings of the lighting systems should be uniformly in one part of the tolerance ranges shown, i.e. towards the top, the centre or the bottom.
- For the purposes of developing this table, it is assumed that RVR values are based on an intensity of 1 000 cd and a background luminance of 15 cd/m². Where RVR measurement is not available, meteorological visibility will apply.
- Where provided, these lights are to be operated at the intensities shown; however, their provision is optional for these visibilities.
- These intensity settings may need to be increased for take-off in RVRs below 400 m.

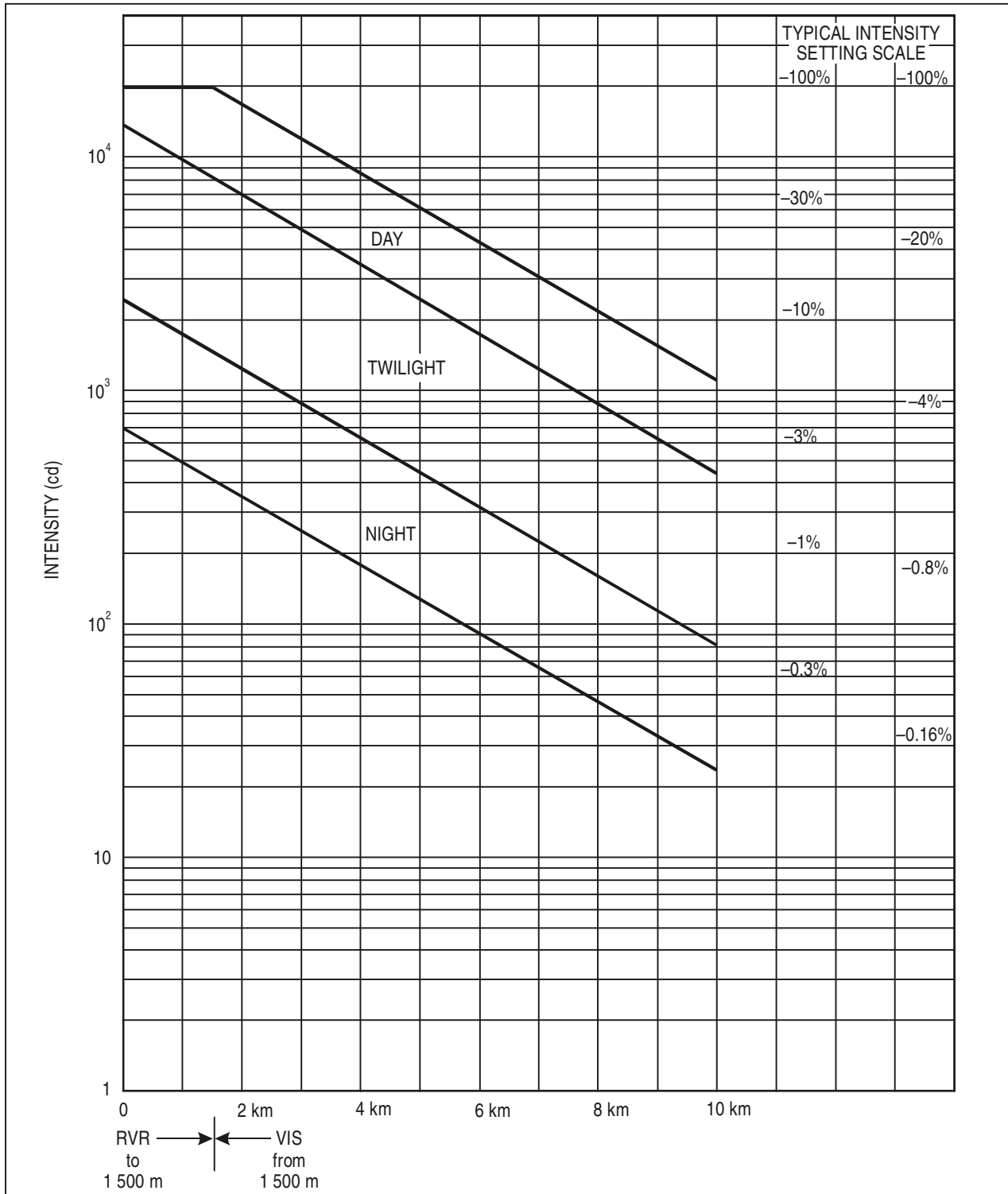

Note.— Day = background luminance 1 000 to 40 000 cd/m²
 Twilight = background luminance 15 to 1 000 cd/m²
 Night = background luminance 15 cd/m²

Figure 5-1. Approach centre line and crossbars

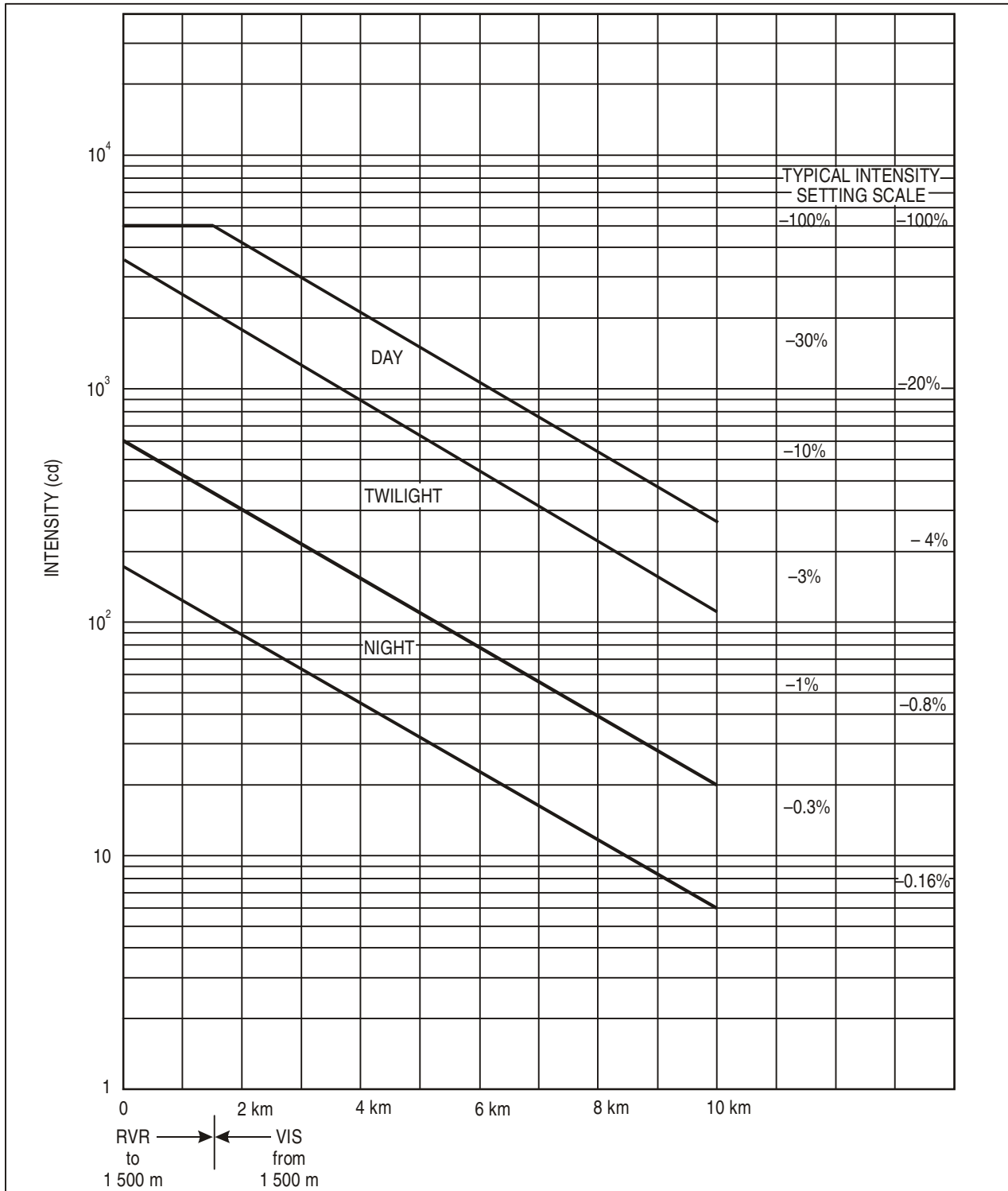

Note.— Day = background luminance 1 000 to 40 000 cd/m²
 Twilight = background luminance 15 to 1 000 cd/m²
 Night = background luminance 15 cd/m²

Figure 5-2. Approach side row, touchdown zone and runway centre line

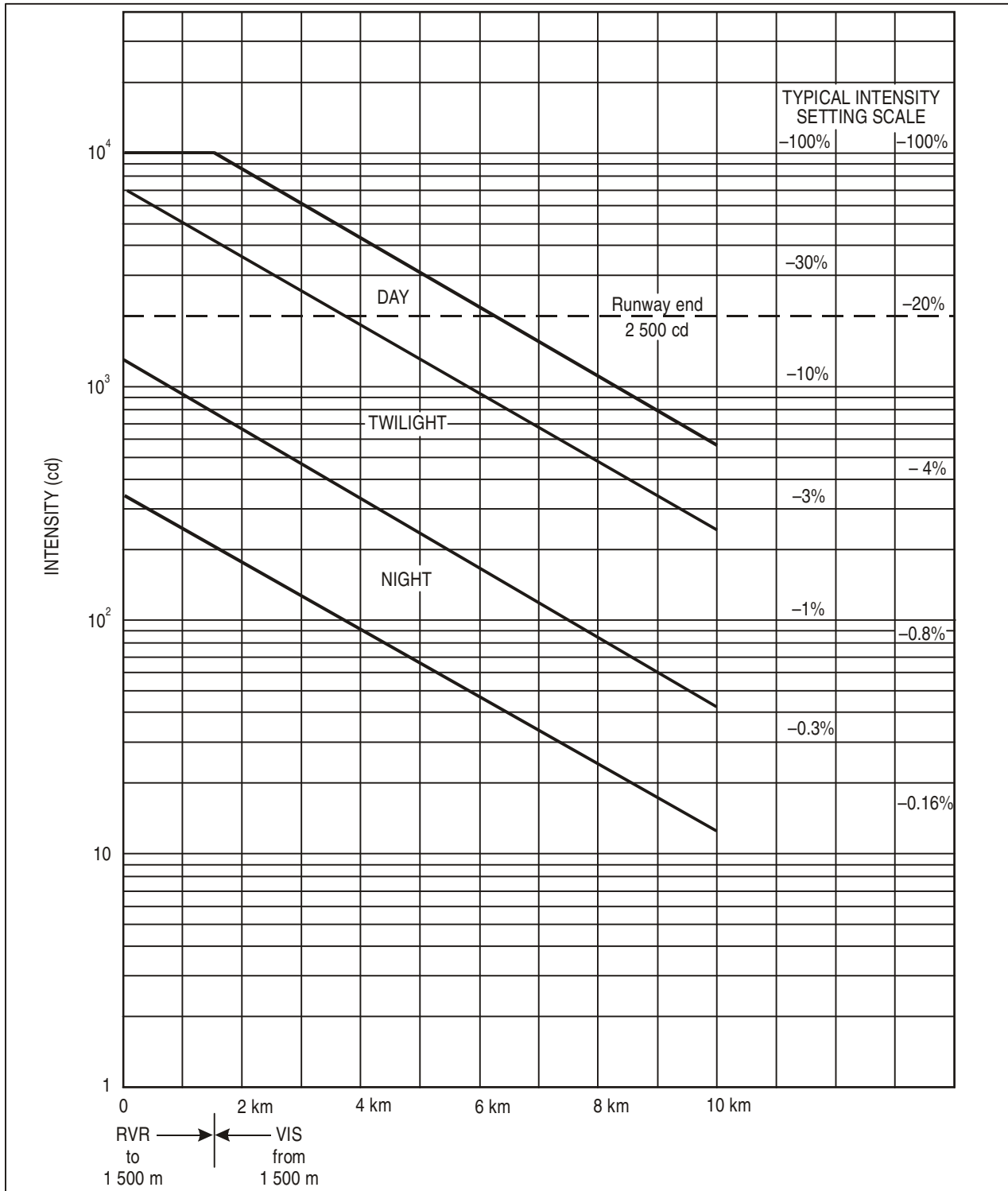

Note.— Day = background luminance 1 000 to 40 000 cd/m²
 Twilight = background luminance 15 to 1 000 cd/m²
 Night = background luminance 15 cd/m²

Figure 5-3. Threshold and wing bar, runway end and runway edge

Chapter 6

Runway Lead-in Lighting System*

6.1 A runway lead-in lighting system may be required to provide positive visual guidance along a specific approach path, generally segmented, where special problems exist with hazardous terrain, obstructions and noise abatement procedures. Such a system consists of a series of flashing lights installed at or near ground level to indicate the desired course to a runway or final approach. Each group of lights is positioned and aimed so as to be conveniently sighted from the preceding group. The approaching aircraft follows the lights under conditions at or above approach minima. The path may be segmented, straight, or a combination thereof, as required. The runway lead-in lighting system may be terminated at any approved approach lighting system, or it may be terminated at a distance from the landing threshold which is compatible with authorized visibility minima permitting visual reference to the runway environment. The outer portion uses groups of lights to mark segments of the approach path beginning at a point within easy visual range of a final approach fix. These groups may be spaced close

enough together (approximately 1 600 m) to give continuous lead-in guidance. A group consists of at least three flashing lights in a linear or cluster configuration and may be augmented by steady burning lights where required. When practicable, groups should flash in sequence toward runways. Each system must be designed to suit local conditions and to provide the visual guidance intended. A typical layout of such a system is illustrated in Figure 6-1.

6.2 In some locations there may be a need for very accurate horizontal guidance due to the presence of obstacles or residences located near the normal approach path. In such cases, the system needs to be augmented at each group by a light that accurately provides alignment information.

* Material provided by the United States.

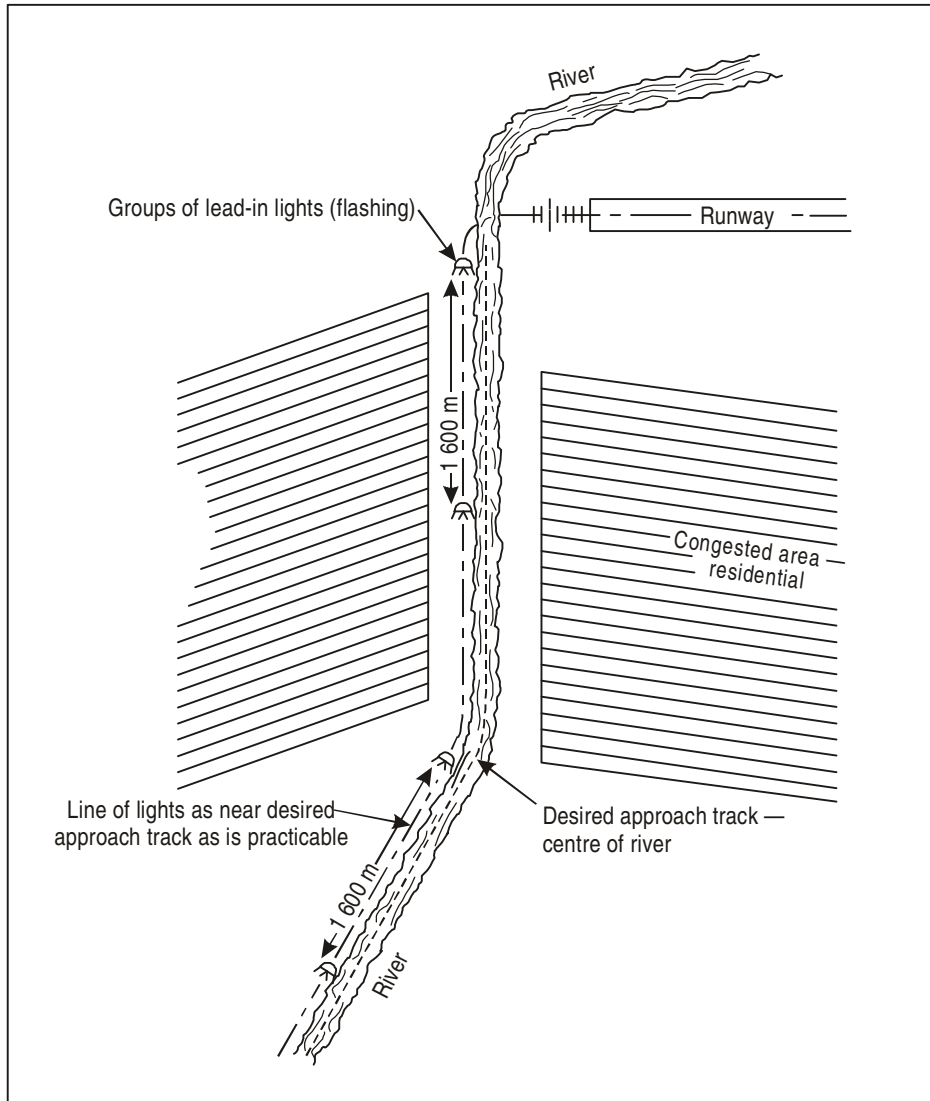

Figure 6-1. Typical layout for runway lead-in lighting system

Chapter 7

Circling Guidance Lights

7.1 INTRODUCTION

7.1.1 Paragraphs 1.4.10 and 1.4.36 of this manual explain how circling guidance lights are used in visual meteorological conditions (VMC) and instrument meteorological conditions (IMC), respectively. Additionally, Figure 1-3 illustrates the standard traffic pattern for VMC. The *Procedures for Air Navigation Services — Aircraft Operations*, Volume II — *Construction of Visual and Instrument Flight Procedures* (Doc 8168), Part III, Section 1.8, contains guidance on constructing visual manoeuvring (circling) areas and calculating their dimensions.

7.1.2 For a circling approach the following guidance should be provided:

- a) adequate indication of the direction or location of the runway. This would enable a pilot to join the downwind leg or align and adjust the track to the runway;
- b) a distinct indication of the threshold so that a pilot can distinguish the threshold in passing; and
- c) adequate indication of the extended runway centre line in the direction of the approach and compatible with the threshold indication to enable a pilot to judge the turn onto base leg and final approach.

7.1.3 The need for and design of circling guidance lights vary from location to location depending on such factors as the circling approach procedure used, the types of aircraft using the runway, meteorological conditions, and types of lights available. At most airports, runway edge lights and approach lighting systems provide all the guidance that is required. Consequently, special lights for circling guidance would be needed only where these systems do not satisfactorily provide the guidance identified in 7.1.2. The provision of additional lights for circling guidance is not usually a major problem. In general, the lights should be designed and installed in such a manner

that they will be visible from the downwind leg but will not dazzle or confuse a pilot when approaching to land, taking off or taxiing.

7.2 LIGHTING REQUIREMENTS

7.2.1 The following paragraphs describe to what extent the requirements detailed in 7.1.2 are met by the Annex 14, Volume I, lighting systems and how they can be improved to provide adequate guidance for circling approaches where such improvement is required.

Lights to indicate the direction of the runway

7.2.2 Annex 14, Volume I, Chapter 5, incorporates specifications for runway edge lights. These lights are primarily intended to define the lateral limits of the runway to aircraft on final approach. However, Annex 14, Volume I, particularly emphasizes that the runway edge lights shall show at all angles in azimuth when they are intended to provide circling guidance. Low-intensity lights which are used for operations on clear nights are generally omnidirectional and therefore comply with this requirement. High-intensity lights which are used for operations under poor visibility conditions are bidirectional but may also be designed to emit a low-intensity omnidirectional light capable of providing circling guidance. If circling guidance is to be provided by this type of light fitting, it is necessary to ensure that the required low-intensity output can be achieved when the high-intensity lighting is operated at the low outputs normally used on clear nights. This is normal practice in order to avoid glare problems during the final approach and landing. An output of 50 cd at maximum brilliancy will reduce to less than 0.5 cd when a night setting is used for the high-intensity lighting. Where a low-intensity omnidirectional light is not included with the high-intensity lights, additional lights should be installed along the runway edges to provide circling guidance. If these additional lights

are high-intensity lights, they should be unidirectional with their beams at right angles to the runway centre line and directed away from the runway. The colour of these lights should preferably be white, but yellow light such as is emitted by some forms of gas discharge may be used.

Lights to indicate the threshold

7.2.3 Annex 14, Volume I, Chapter 5, recommends the installation of two white flashing lights at the threshold of a non-precision approach runway when additional threshold conspicuity is required or where it is not possible to install other approach lighting aids. Additional conspicuity may also be necessary when the runway threshold is permanently or temporarily displaced. These lights can also be used on other runways to facilitate identification of the threshold, particularly in areas having a preponderance of lighting or where featureless terrain exists. If the lights have a wide or omnidirectional beam spread or are oriented at right angles to the runway, they will provide circling guidance.

Lights to indicate the extended runway centre line

7.2.4 The centre line lights of all the approach lighting systems specified in Annex 14, Volume I, Chapter 5, are intended to define the extended centre line of the runway. Low-intensity systems are normally designed with omnidirectional lights, and thus they will provide circling guidance as well. High-intensity systems employ unidirectional lights which will not be visible to a pilot on the downwind leg. Such systems can be improved by installing additional lights either adjacent to the existing lights or beyond the outer end of the approach lighting system (along the extended centre line). These lights should be steady burning or flashing. Where lights are installed beyond the outer end of an approach lighting system, the intensity and beam spread of the lighting should be adequate to be visible from the downwind leg. Where flashing lights are used, they should flash in sequence at the rate of one per second, starting at the outermost light and proceeding towards the threshold.

Chapter 8

Visual Approach Slope Indicator Systems

8.1 GENERAL

8.1.1 The visual approach slope indicator systems defined in Annex 14, Volume I, Chapter 5, are designed to give visual indications of the desired approach slope. There are four standard systems, i.e. T-VASIS, AT-VASIS, PAPI and APAPI. These systems have been proven by operational experience.

8.1.2 The material in this chapter is intended to provide guidance in the application of Annex 14, Volume I, Chapter 5, 5.3.5, considering that:

- a) light units of different designs are in use;
- b) systems are installed on airports of widely divergent physical characteristics; and
- c) systems are used by both the largest and the smallest types of aircraft.

8.1.3 Annex 14, Volume I, Chapter 5, Figure 5-20 and Table 5-3, detail the characteristics (viz. the origin, dimensions and slope) of the obstacle protection surfaces of T-VASIS, AT-VASIS, PAPI and APAPI. Since these surfaces have been patterned generally on the lines of the approach surface of the runway, the data collected during the obstacle survey of the latter surface will be useful in determining whether or not objects extend above an obstacle protection surface. Where an aeronautical study indicates that an object extending above the obstacle protection surface could affect the safety of operations of aeroplanes, then one or more of the following measures shall be taken to eliminate the problem:

- a) raise the approach slope of the system;
- b) reduce the azimuth spread of the system so that the object is outside the confines of the beam;
- c) displace the axis of the system and its associated obstacle protection surface by no more than 5 degrees;

d) displace the threshold; and

- e) where d) is found to be impracticable, displace the system upwind of the threshold to provide an increase in the threshold crossing height equal to the amount by which the obstacle penetrates the obstacle protection surface.

8.1.4 The large azimuth coverage of the system provides valid information to aircraft on the base leg, but this information should not be solely relied upon for descent purposes unless an aeronautical study has been conducted to verify that there are no obstacles within the coverage of the system. Where an object located outside the obstacle protection surface of the system, but within the lateral limits of its light beam, is found to extend above the plane of the obstacle protection surface and an aeronautical study indicates that the object could adversely affect the safety of operations, then the azimuth spread of the light beam on the relevant side should be restricted so that the object is outside the confines of the light beam.

8.1.5 Although the normal approach slope is 3 degrees, a different approach slope may be selected to achieve a visual approach slope angle which equals the approach slope angle of a non-visual glide path, when provided. If obstacles are present in the approach area, a higher approach slope angle may be selected.

Note.— Approach slope angles in excess of approximately 3 degrees are not normally used in the operation of large transport aircraft, but are used to facilitate the operation of small transport aircraft at some aerodromes.

8.1.6 The indications provided define one normal approach path plus seven discrete deviation indications in the case of T-VASIS, one normal approach path and four discrete deviation indications in the case of PAPI and one normal approach path and two discrete deviation indications in the case of APAPI.

Note 1.— In this chapter, T-VASIS is meant to imply also AT-VASIS and PAPI to imply also APAPI.

Note 2.— Visual approach slope indicator systems provide essential visual cues to pilots on approach ensuring:

- a) a safe minimum wheel clearance over the runway threshold;
- b) a safe margin clear of all obstacles when on final approach; and
- c) correlation with non-visual glide path signals where precision instrument approach equipment is installed.

Note 3.— The visual and non-visual on-course signal may diverge very near the threshold as a result of a difference between the antenna height and the pilot eye height.

8.1.7 In preparing a design for the installation of a system, it may be necessary to change the dimensions stated in the ideal layout due to the location of taxiways or other features alongside the runway. It has been found that these dimensions may be changed by up to 10 per cent without impairing the operation of the system.

8.1.8 The contours of the runway strip should not cause any apparent distortion to the system when viewed by a pilot on the correct approach slope. The light units are therefore shifted to compensate for the difference in the level between the threshold and the final position of the light units, a longitudinal movement of 19 times the difference in level being required for a 3-degree approach slope.

8.1.9 For T-VASIS, when viewed along the approach slope, a light unit should appear to be at the same level as any equivalent light on the other side of the runway. After having allowed for the difference in height between the opposite sides of the runway, the difference between the longitudinal location of each of the light units of a matching pair should be less than 1.5 m.

8.1.10 Normally, concrete foundations are provided to hold the pillars supporting the light units. So as not to be an obstacle to an aircraft overrunning the installation, either the slab should be depressed below ground level or the sides of the slab sloped so that the aircraft would ride over the slab without damage to the aircraft. In the former case, the cavity above the slab should be backfilled with appropriate material. This, together with the frangible construction of units and their supports, minimizes the damage that would be sustained by an aeroplane should it run over a unit. If the light units are not designed to withstand the effects of jet efflux from an aircraft taking off or turning on the runway, the provision of a baffle to deflect the blast and other steps to secure the unit may be necessary.

8.2 T-VASIS

Siting

General

8.2.1 A simple graphical method is suggested for designing the layout of a T-VASIS or AT-VASIS.

Definitions

8.2.2 In T-VASIS siting design, the following terms are used:

- a) **Standard layout.** This is shown in Figure 5-15 of Annex 14, Volume I, Chapter 5, and is based on a standard approach slope of 3 degrees and a perfectly level runway strip.
- b) **Eye height over threshold.** The theoretical height of the pilot's eye as the aircraft passes over the actual threshold on a correct approach slope signal of the T-VASIS. For a standard system it is 15 m.
- c) **Approach slope.** The standard approach slope is 3 degrees. This angle may be varied by the competent authority where necessary due to obstacle clearance, harmonization with an ILS, or other such considerations. The standard 3-degree approach slope is an actual gradient of 1:19.08. In this graphical design method, a gradient of 1:19 is used for convenience while still retaining adequate design accuracy.
- d) **Displacement.** The movement of the whole system away from or towards the threshold. It varies the eye height over the threshold from the standard dimension of 15 m but causes no change to the pattern seen by the pilot from the air.
- e) **Distortion.** The light units in the legs of the "T" pattern are normally located at standard intervals of 45 m, 90 m and 90 m respectively from the wing bar along a line through the centre of the wing bar and parallel to the runway. If it is necessary to apply a tolerance to these dimensions, the result is called distortion because it will tend to distort the pattern seen by the pilot.
- f) **Terrain compensation.** Because the runway strip is generally not at the same level as the threshold, the

location of the light units at the standard spacing along the horizontal plane through the threshold is not suitable. A further dimensional change is necessary resulting in the light units being located at ground level at a point where a line parallel to the approach slope, and passing through the theoretical point of the light unit on the horizontal plane, intersects the ground profile.

- g) **Light unit location chainage.** This is the actual location where the light source of each light unit should be located, at ground level. In practice, it may be taken as the rear edge of each light unit and is used as the reference datum for the actual installation of each light unit. This approximation remains valid so long as all nominally ground-level light units (i.e. those not mounted on extension pillars) are mounted a uniform and minimum distance above ground level.

8.2.3 The final light unit location chainage is composed of a standard dimension with adjustments, within the tolerances described below, for:

- displacement;
- distortion; and
- terrain compensation.

Tolerances

8.2.4 **Eye height over threshold.** The standard dimension of 15 m may be varied by a maximum of +1 or -3 m, giving an allowable range of 12 m to 16 m. A variation outside these limits should be referred to the competent authority for consideration.

8.2.5 **Displacement.** Displacement and eye height over threshold are directly related and a variation of one directly affects the other by the ratio of the approach slope.

Note.— For a standard approach slope of 3 degrees (1:19) and eye height over threshold of 15 m, the wing bar is 285 m from threshold. By varying the height over threshold between 12 m to 16 m, the wing bar varies from 228 m to 304 m which corresponds to a maximum displacement of 57 m towards and 19 m away from the threshold respectively.

8.2.6 **Distortion.** The standard longitudinal distance between the wing bar and the units forming the legs of the “T” pattern, as per 8.2.2 e), may be varied by a maximum tolerance of ± 10 per cent.

Note.— This tolerance may be used to avoid taxiways, etc. It should be clearly understood that the 10 per cent tolerance is distinct from variations from standard caused by terrain compensation.

8.2.7 **Terrain compensation.** Although any T-VASIS siting design may take advantage of all, or any combination of, the tolerances applicable to eye height over threshold/displacement, or distortion, the effect of terrain compensation must also be considered for each light unit. Particular attention must be given when locating units near taxiways or cross runways, and in certain circumstances raising of light units on extension pillars may also be considered for this purpose as discussed in 8.2.16.

8.2.8 The longitudinal line of leg light units which are parallel to the centre line of the runway shall be located at a distance of 30 m (± 3 m) from the edge of the runway. The edge of the runway shall be defined as the distance from the runway centre line which is half the nominal width of the runway, excluding shoulders.

8.2.9 Thus, at the design stage of the project, the following tolerances shall apply:

Dimension: Height of approach slope at threshold
Standard: 15 m
Allowable tolerance: +1 m, -3 m (height over threshold)

Dimension: Leg light unit spacing
Standard: 45 m
Allowable tolerance: ± 4.5 m (distortion)
Standard: 90 m
Allowable tolerance: ± 9 m (distortion)

Dimension: Distance of longitudinal line of light units from runway edge
Standard: 30 m
Allowable tolerance: ± 3 m.

Location survey

8.2.10 Before the actual location for each light unit of the system can be determined, a survey of the area must be taken. The survey should cover an area around the anticipated bar positions and the two lines of the leg units. Also a level on the runway centre line must be taken at the threshold. Levels within the areas where the light units will be located should be taken at points 10 m apart so that intervening levels may be fairly accurately estimated, should the position of a light unit fall between the points at which levels have actually been taken. As well as levels, the survey should include location and dimensions of any

pavements, objects, ducts, drains, etc., likely to obstruct the placement of light units. Figure 8-1 shows the location at which survey points are required.

Obstacle clearance

8.2.11 As the T-VASIS night signal may be visible out to approximately 15 degrees either side of the extended runway centre line (i.e. well beyond the obstacle protection surface), it is recommended that the installation designer ascertain the likely terrain infringement that can be expected in this unprotected area, and determine:

a) the practicalities of obstacle removal;

b) the necessity of azimuth restriction;

c) the necessity of taking other appropriate actions, including lighting of obstacles.

Design

8.2.12 Figure 8-2 shows a T-VASIS design for a standard 3 degree (1:19) approach slope and a standard 15 m eye height over threshold. When designing for other figures, either within the allowable tolerances or outside the allowable tolerances with competent authority approval, the appropriate variations shall be incorporated where applicable.

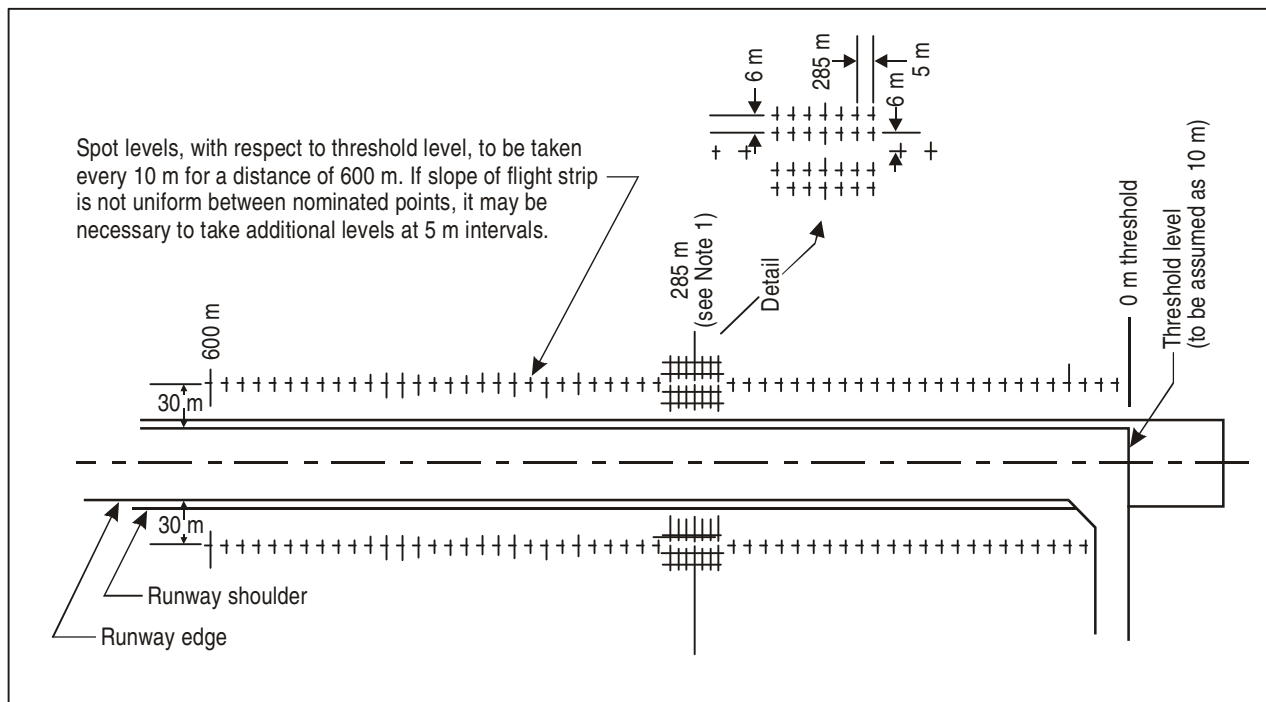

NOTES:

1. Grid point for levels to be moved 10 m along the runway for every 0.5 m of difference between assumed threshold level (10 m) and the highest level of the four grid levels on the 285 m line, e.g. threshold level 10 m, 285 m level 9.5; grid to be moved 10 m away from threshold.
2. Levels not required on any intersecting taxiways.
3. Any object, duct, drain, etc., likely to obstruct the placement of the light unit, to be shown and dimensioned.

Figure 8-1. T-VASIS location survey

8.2.13 Where a T-VASIS or an AT-VASIS is to be installed to complement an ILS (or MLS), it shall be designed to be compatible with the ILS (or MLS) glide path. An eye height over threshold 1 m higher than the ILS glide path height over threshold has been found to satisfy most aircraft. Large aircraft with a pilot eye-to-antenna height significantly greater than 1 m in the approach attitude can harmonize instrument and T-VASIS approach slope cues by flying the T-VASIS “wing bar and one light fly-down” as their on-slope signal.

8.2.14 Using the level of the threshold on the runway centre line as the datum, a profile is drawn of the levels in the strip along the line of the port or starboard leg light units 30 m from the runway edge.

Note 1.— An exaggerated vertical scale assists in plotting the levels and increases the accuracy when determining light unit locations.

Note 2.— It is important at this stage to show the limits of any taxiways or cross runways and their clearance limitations, on the profile, to indicate where light units cannot be located.

8.2.15 Through a point at the standard height over threshold of 15 m, draw a 1 in 19 slope line to intersect the profile at the approximate location of the wing bar. Using the survey data, plot the longitudinal profiles of each of the wing bar light units. The intersection of the slope line with the highest of these four profiles is the location chainage of the reference wing bar light unit.

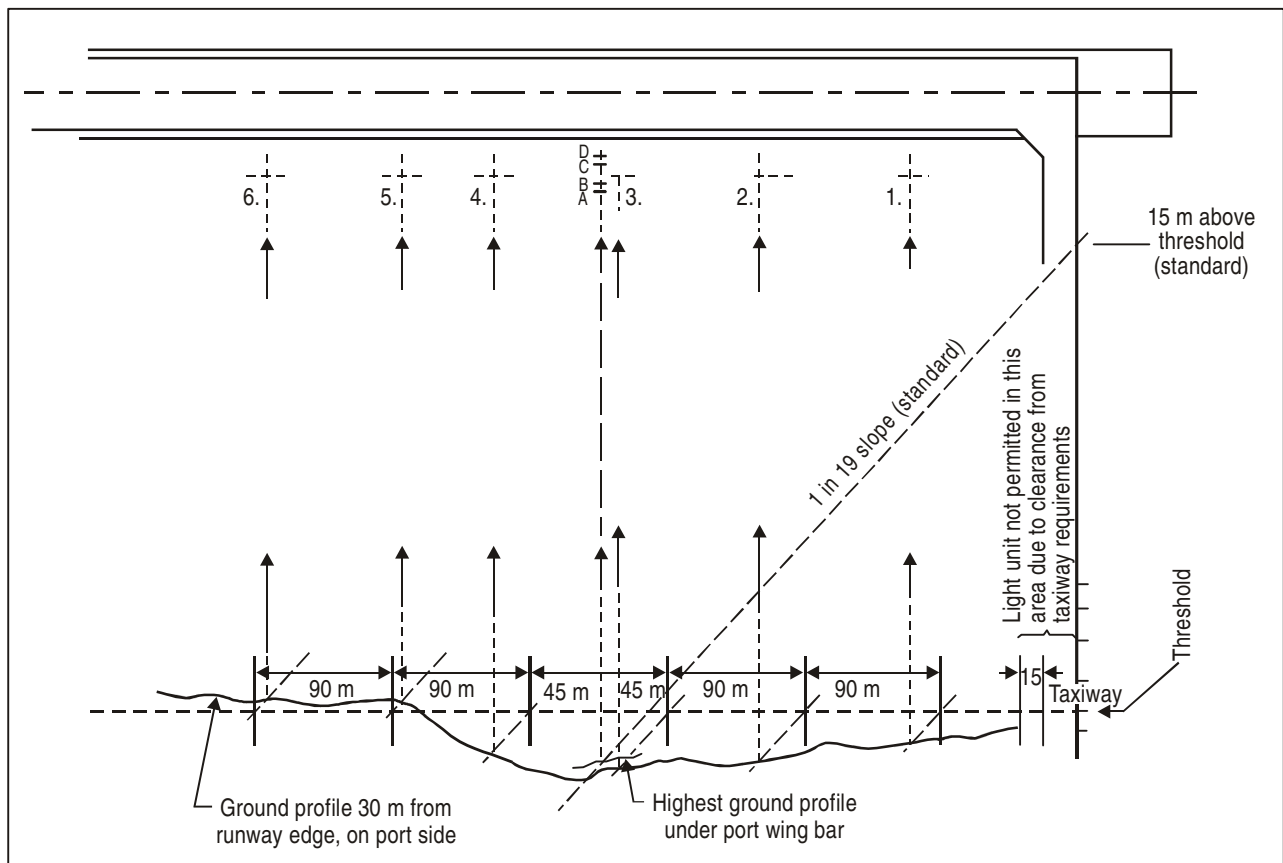

Figure 8-2. T-VASIS design for a 3-degree approach slope and 15 m eye height over threshold

Note 1.— Where an approach slope other than 1 in 19 is to be applied, the gradient shall be determined to an accuracy which is practical for use with this graphical method, but which shall not differ from the actual calculated gradient by more than 0.1.

Note 2.— There is generally a transverse slope away from the runway such that the wing bar light unit nearest the runway would be the highest and would therefore be the reference light unit for the wing bar.

8.2.16 Since the four light units in the wing bar are required to be mounted at the same level, to within a tolerance of ± 25 mm, the remaining light units will need to be mounted on pillars unless the difference in level is small or all positions are at the same level. The length of pillars may be determined from the differences in ground level between the light unit locations.

8.2.17 Draw a horizontal line at a convenient position, i.e. just above the threshold level and clear of the ground profile. Starting from the point of intersection of this line with the slope line previously drawn, running distances of 45 m, 90 m and 90 m are marked out in each direction along the horizontal line. From these points, lines are drawn parallel to the previous slope line to intersect the ground profile. These new points of intersection are the location chainages of each leg light unit.

Note.— Where the standard interval between the wing bar and the adjacent leg light units is varied to take advantage of the distortion tolerance, the wing bar shall, wherever possible, be located midway between the adjacent leg light units.

8.2.18 Where this design results in a light unit being located within 15 m of a cross runway or taxiway, the tolerances of displacement and distortion or the use of pillars as described in 8.2.22 shall be employed to locate it outside the restricted area.

8.2.19 If the design is for a double-sided T-VASIS, the same procedure is repeated to determine the positions of all of the light units on the other side of the runway. The slope lines used to determine the light unit location chainages must be common for both sides of the system.

Clearance from pavements

8.2.20 A minimum clearance of 15 m shall be provided between any part of a T-VASIS light unit (but not the foundation slab) and an adjacent runway or taxiway pavement.

Note.— This 15 m clearance places certain restraints on the siting of a system. For instance, it is not possible to have a 22.5 m taxiway passing through the space between the wing bar and either of the adjacent leg light units. On the other hand, an intersecting runway can normally pass between adjacent leg light units not adjoining the wing bar.

8.2.21 A light unit may be made to appear further away from threshold than its actual position by elevating it on pillars, the apparent change being 19 units longitudinally for each unit of elevation, i.e. the standard 1:19 approach slope. (The ratio of this apparent change will vary accordingly for other approach slope angles.)

8.2.22 Where appropriate, pillars may be used to relocate light units to maintain clearance from nearby pavements. The maximum allowable height of a pillar is 0.6 m. The use of pillars should be avoided if at all possible where the light units are located in positions which are vulnerable to direct aircraft jet blasts. Where pillars are used, their height shall be recorded on the T-VASIS site plan and also permanently on a metal plate, or similar, secured to the foundation slab.

Arithmetical check

8.2.23 Following the graphical determination of the light unit location chainages, it is recommended that an arithmetical check of the design be made to determine if the design locations are accurate and the light unit locations on both sides of the runway are compatible. A suggested proforma for use in making and recording the arithmetic check is shown in Figure 8-3.

8.2.24 On the proforma the following terms are used:

- a) **Plotted distance (column 2).** This is the chainage from the threshold to the light unit location chainage, as determined graphically.
- b) **Level difference (column 3).** The difference between the threshold level and the ground level at the light unit location chainage, as derived from the survey data. In the case of the wing bar, the level of the highest light unit location is used. Where pillars are used on leg light units, the height of the pillars shall be included in this level difference value.
- c) **Terrain compensation (column 4).** The distance a light unit is shifted from its standard position due to a difference between the threshold level and the

Location		No.							
Threshold level									
Angle of approach slope									
Height of approach plane above threshold									
Distance of line of leg units from runway edge									
1	2	3	4	5	6	7	8	9	10
Light unit no.	Plotted distance	Level difference	Terrain compensation (Col 3 × 19)	Standard distance	Calculated distance (Col 5 + Col 4)	Difference (Col 2 & Col 6)	Calculated chainage (Col 4 P-S)	Plotted chainage (Col 2 P-S)	Difference (Col B & Col 9)
1									
2									
3									
Wing									
4									
5									
6									
7							Survey Plan No.		
8									
9									
Wing							Location Plan No.		
10									
11									
12							Pilot Sheet No.		

Remarks:

Signature _____

Date _____

Figure 8-3. Proforma for arithmetic check of T-VASIS design

ground level at the light unit. For a standard 1:19 approach slope system, it is the level difference (column 3) multiplied by 19. For other than 3-degree systems, the multiplication factor is as determined in Note 1 to 8.2.15.

- d) **Standard distance (column 5).** The distance from the threshold to the light unit location chainage if the installation were on level ground. Any displacement or distortion of the layout due to taxiways, etc., is to be incorporated into the standard distance for the purpose of the arithmetical check.
- e) **Calculated distance (column 6).** This is the sum of the standard distance (column 5) and the terrain compensation (column 4).
- f) **Difference between columns 2 and 6 (column 7).** This is a comparison representing the difference between the plotted and the calculated distance from the threshold to the light unit location chainage. If the difference is less than 1.5 m, the design is acceptable; if not, the graphical layout should be re-examined.

8.2.25 Because each pair of the corresponding light units and wing bars on the starboard and port side should appear to be at the same level when viewed down the approach slope, the following points should be checked:

- a) **Calculated chainage variation (column 8).** This is the difference in calculated chainage of a starboard light unit with respect to the corresponding port light unit, from column 4.
- b) **Plotted chainage variation (column 9).** This is the difference in plotted chainage of a starboard light unit with respect to the corresponding port light unit, from column 2.
- c) **Difference between columns 8 and 9 (column 10).** This is the difference between the calculated chainage variation and the plotted chainage variation. If the difference is less than 1.5 m, the design is acceptable; if not, the graphical layout should be re-examined.

Note.— In making this check, it is essential that the use of signs in columns 7 and 9 be consistent.

8.2.26 For an AT-VASIS, the instructions in 8.2.25 do not apply.

Site plan

8.2.27 On completion of the siting design and arithmetical check, a site plan of the proposed installation should be prepared, showing all pavement and other physical features, such as drains in the area, all light unit location chainages and pillar heights, if applicable.

Computation of minimum eye height over the threshold (MEHT) values

8.2.28 Annex 14, Volume I, 2.12 e), specifies that information on the MEHT* values of T-VASIS (AT-VASIS) be published in the relevant aeronautical information publication. This shall be the lowest height at which only the wing bar(s) are visible; however, the additional heights at which the wing bar(s) plus one, two or three fly-down light units come into view may also be reported if such information would be of benefit to aircraft using the approach. The MEHT for a T-VASIS (AT-VASIS) is the height over threshold of the top of the white signal of the first fly-up light unit of the system (i.e. the one closest to the wing bar; see Annex 14, Volume I, Figure 5-17). Similarly, the height over threshold of the top of the white signal of the wing bar represents the minimum height at which the wing bar(s) plus one fly-down unit would become visible. The same procedure is used to calculate the heights at which the wing bar plus two or three fly-down units would become visible.

Eye height over threshold

8.2.29 Based on the nominal eye height over threshold being 15 m, pilots may select from the following table a visual approach path indication that provides the required wheel clearance over the threshold:

<i>Visible lights</i>	<i>Eye height over threshold</i>
Wing bar only	13 m to 17 m
Wing bar and one fly-down unit	17 m to 22 m
Wing bar and two fly-down units	22 m to 28 m
Wing bar and three fly-down units	28 m to 54 m

* MEHT is the lowest height at which the pilot will perceive an on-slope indication over the threshold.

Note.— At eye heights above approximately 30 m, i.e. twice the nominal approach slope, the lights will become progressively invisible, beginning with the wing bar.

T-VASIS light units (blade type)

Description of light units

8.2.30 The T-VASIS employs three types of light units which are of the same basic construction and vary only in detail. The three variations are:

- a) The fly-down light unit, shown in Figure 8-4 A), is located in the leg of the inverted “T” and carries a rear cut-off blade fitted above the beam and a front cut-off blade below the beam. It provides a beam extending from an elevation of 6 degrees down to approximately the approach slope where it has a sharp cut-off. Its fibreglass lid does not extend to the front of the light unit.
- b) The bar light unit, shown in Figure 8-4 B), is located in the horizontal bar of the “T”. It features a rear cut-off blade fitted above the beam and a red filter at the lower part of the front. This light unit produces a beam from ground level up to 6 degrees, the lower part up to 1°54' being red. The lid, as in the fly-down light unit, does not cover the front part of the unit.
- c) The fly-up light unit, shown in Figure 8-4 C), is located in the leg of the upright “T” and has a rear cut-off blade below the beam which, with a front blade above the beam, provides a sharp cut-off at the top of the beam. A red sector of light is formed by the rear red filter fitted above the beam and a front blade fitted below the beam. This light unit produces a beam from approximately the approach slope down to ground level, the lower part below 1°54' being red. Unlike the other types of light units, the fly-up light unit is fully covered.

8.2.31 The blades of each light-unit assembly have two small posts attached at either end, on top of which pads are fastened. The blade is assembled such that the dimension between the working surface of the blade and the pad is kept within fine design tolerances.

8.2.32 Using the pad on the rear blade and the pad on the front blade, a specially designed and highly sensitive

level is placed on the posts; the unit is then adjusted until the pads are level, resulting in the light unit being adjusted to the specified angle.

Lamps

8.2.33 Most types of lamps used in aerodrome lighting are designed for use in precise projection equipment to produce a controlled beam of light complying with the required standards. In this respect, T-VASIS lamps are no exception. Because of the rather narrow beam spread, especially in elevation, and the relatively high intensities required of the system, it has been found that PAR lamps (bulbs constructed from two moulded glass parts, the reflector and the lens, which are fused together) are best suited to the requirements.

8.2.34 Each lamp is adjustable in azimuth and elevation, and two separate groups of lamps operate on separate circuits for day and night operations respectively.

Final adjustment

8.2.35 Final adjustment of the system involves the correct aiming of each lamp, together with cross-levelling and precise longitudinal levelling of each light unit. The precision of the whole system is dependent upon the care taken in these adjustments.

8.2.36 By using the level to adjust first one side of a light unit and then the other, it is possible to adjust the whole system so that the cut-off edges of the resulting light beams are within thirty seconds of arc of the required angles of elevation.

8.2.37 Once all the light units have thus been set, a check on the level of each unit should be carried out periodically. Initially the interval between checks should be short, but once stability has been proven, it can be extended to every six months.

8.2.38 To achieve a sharp signal and maximum system range, it is essential that the most intense sector of the lamp beams be utilized.

8.2.39 This can be achieved by means of a target which is temporarily installed at the front of the light unit so that each lamp can be correctly aimed by adjustments in azimuth and elevation.

8.2.40 Because of variations in lamp construction, it is mandatory that, after aiming, a visual check be made on

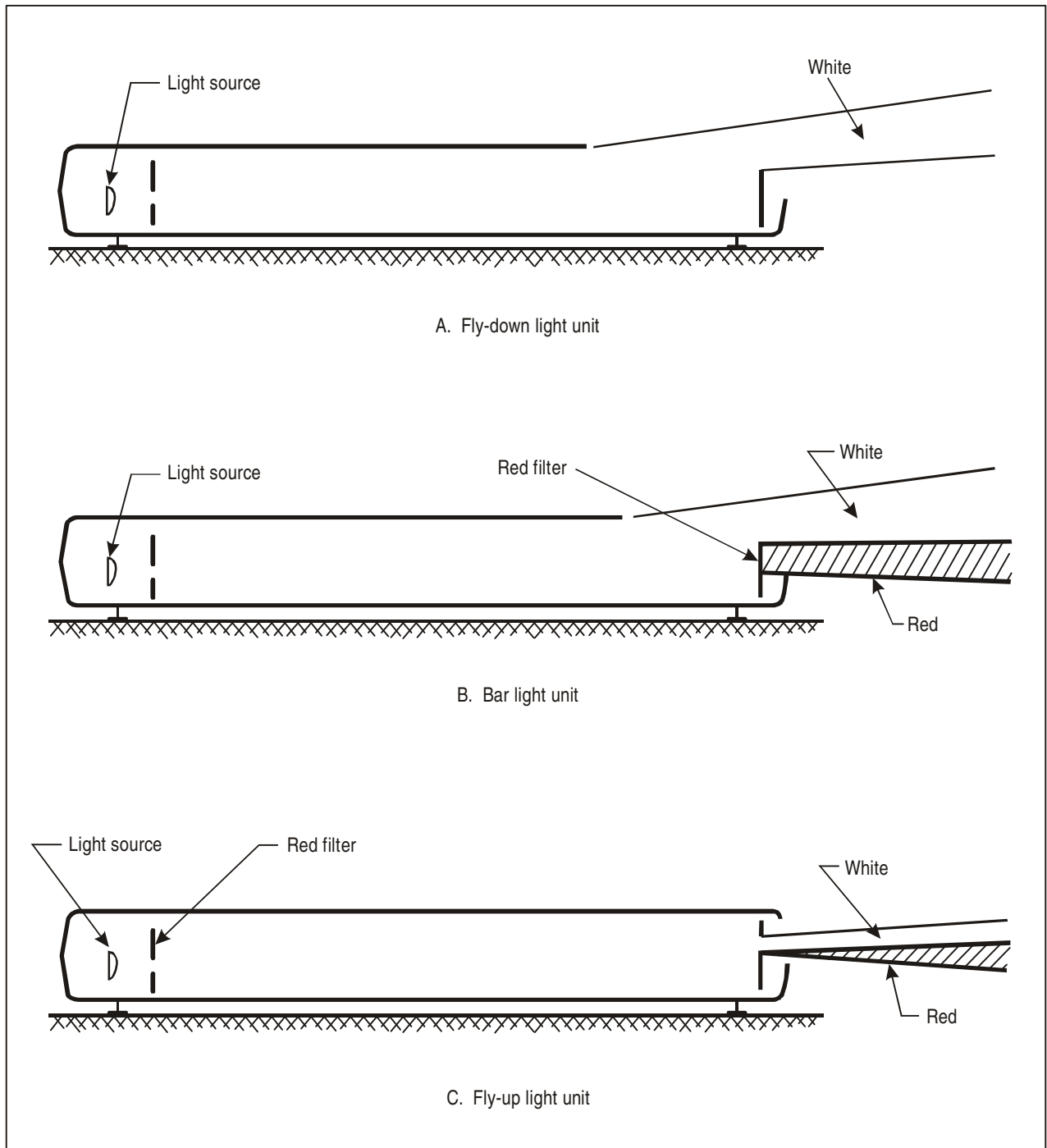

Figure 8-4. T-VASIS light units (blade type)

each light unit from about 10 m away. Through the effective aperture formed by the upper and lower blades, the linearity of intensity can be checked and, if necessary, altered by an assistant to the observer; a check can be made that the signal cuts on or off simultaneously over the whole width, that is, it should not appear to “slide” across the aperture as the observer raises or lowers the eye. In addition, each lamp should show the maximum flashed area — the fine line of light should be continuous, not dotted.

8.2.41 The intensity distribution of the light units shall conform to Annex 14, Volume I, Appendix 2, Figure 2.22.

T-VASIS light units (projection type)

8.2.42 An alternative method of providing the light beams required in a T-VASIS is shown in Figure 8-5.

8.2.43 The beams are formed by illuminating a filter and diaphragm plate located in the focal plane of a projection lens. In addition to replacing the lamp itself, each optical unit which contains all optical components associated with each lamp can also be replaced. A number of optical units are provided for day operations, with a smaller number for night operations.

8.2.44 Because of the construction principles employed, one unit model can be used in all positions of a

T-VASIS, i.e. as wing bar unit, fly-up unit and fly-down unit. The only differences are in the filter and diaphragm plates and in the elevation settings of the optical units. In view of this fact, only one unit is shown in Figure 8-5. The fly-up beam, being the most critical one, was chosen for portrayal.

Lamps

8.2.45 The lamps used in day and in night operations are identical, precision-focused light sources fitted in reflectors. The difference in the beam coverage required for day and night operations is obtained by using different lenses in the day and night optical units.

Final adjustment

8.2.46 Final adjustment consists of cross-levelling and precise longitudinal levelling of the optical assembly. The beam angles having been adjusted in the factory and the optical units being compact and stiff, the subsequent check on beam angles is only confirmatory.

8.2.47 The initial check and later confirmatory ground checks are carried out by means of a device containing a precision level and a telescope in combination with an adjustable checking stick. There is no need for concrete checking stick bases.

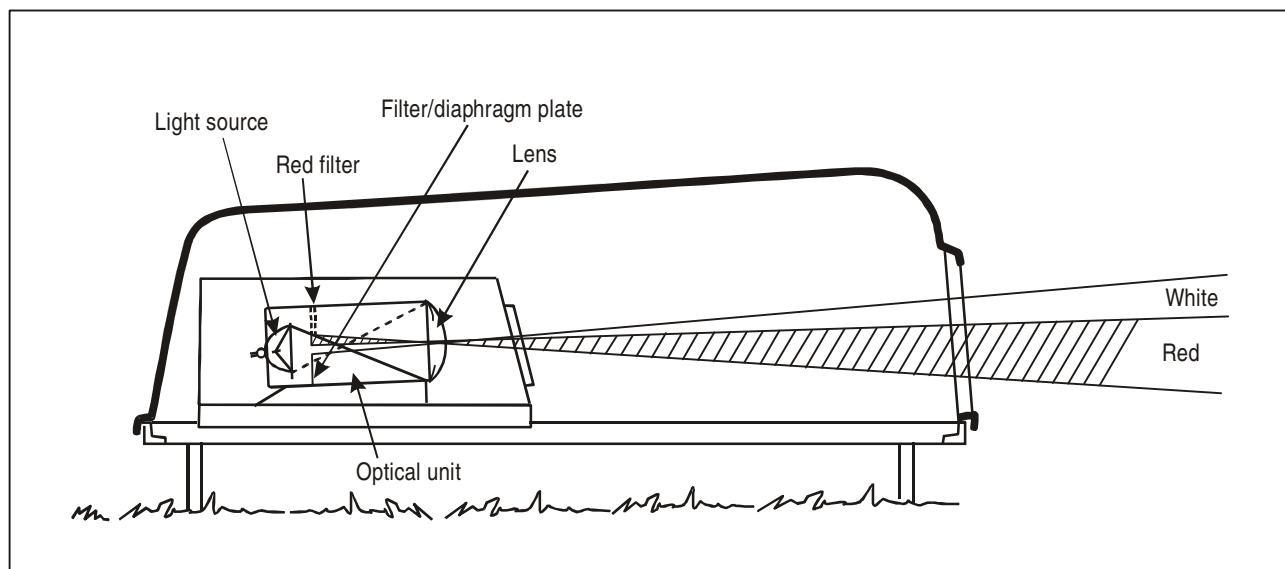

Figure 8-5. T-VASIS fly-up unit — Typical optical system (projection type)

8.2.48 Supply units with three intensity settings for day operations and three intensity settings for night operations are normally provided. In some cases, supply units with five intensity settings are used.

Flight checking

8.2.49 On initial installation a flight check should be carried out, both by day and night, during which the following points should be checked:

- a) The lights appear of uniform intensity throughout the system.
- b) The lights forming the pattern appear to be substantially in a horizontal plane.
- c) The corresponding lights on opposite sides of the runway appear and, where applicable, change colour simultaneously.
- d) The correct approach slope is indicated by the system and the correct cut-off angles are shown.
- e) The fly-down and fly-up light units of the “T” appear in uniform steps as the approach slope changes.
- f) The bars and the fly-up light units of the “T” change colour at the correct angle.
- g) The range from which the system can be flown is acceptable.
- h) The azimuth, measured in relation to the extended runway centre line, through which the system as a whole is visible, both for day and night conditions, is satisfactory.
- i) The progression of the intensity setting stages is acceptable.
- j) The intensity of the system matches that of the runway lights when both are selected in the same setting.
- k) The obstacle clearance with the system “just red” is adequate.

If the actual angles of d), f) and k) are measured during the daylight check, it is not necessary to measure them at night; a subjective assessment is satisfactory.

8.2.50 The following points should be checked on routine flight tests:

- a) The correct approach slope is indicated.
- b) The sensitivity of the “on-slope” signal is acceptable. If the first fly-up and first fly-down light units are set at diverging angles, the sensitivity will be too coarse.
- c) The red signal in the wing bar light units and the fly-up light units is satisfactory.
- d) The change from a full fly-up “T” to a full fly-down “T” occurs in a steady progression and lights on each side of the runway operate simultaneously.
- e) The lights are of uniform intensity.

8.3 PAPI

Layout and elevation setting angles

8.3.1 The arrangement of the PAPI and APAPI units and the resulting displays are shown in Figures 8-6 and 8-7 respectively, together with the standard differential setting angles. The nominal approach angle is shown as ϕ , the MEHT* datum angle as M (see 8.3.22) and the obstacle protection surface as OPS (see 8.3.30 to 8.3.32).

8.3.2 The inner edge of the PAPI unit nearest the runway should be 15 m (± 1 m) from the runway edge. Units should not be closer than 14 m to any taxiway, apron or runway. In the case of APAPI, the inner edge of the unit closer to the runway should be 10 m (± 1 m) from the runway edge. Units should not be closer than 9 m to any taxiway, apron or runway.

8.3.3 The spacing between PAPI units (see Figure 8-6) normally will be 9 m (± 1 m), except that a spacing of not less than 6 m between units may be used where there is insufficient strip width to accommodate all four units at 9 m spacing. In such an event, the innermost PAPI unit should

* MEHT is the lowest height at which the pilot will perceive an on-slope indication over the threshold.

preferably still be located 15 m from the runway edge but should never be located less than 10 m (± 1 m) from the runway edge. The spacing between APAPI units (see Figure 8-7) will be 6 m (± 1 m).

8.3.4 The system should be located on the left side of the runway unless it is impracticable to do so. If the system

is installed on the right side, then the highest set unit should be inboard and the lowest outboard. A combination of left-hand and right-hand arrays gives the symmetrical layouts shown in Figure 8-8 which may be provided when the runway is used by aircraft requiring external roll guidance which is not provided by other means (see note following 5.3.5.23 and 5.3.5.24 of Annex 14, Volume I).

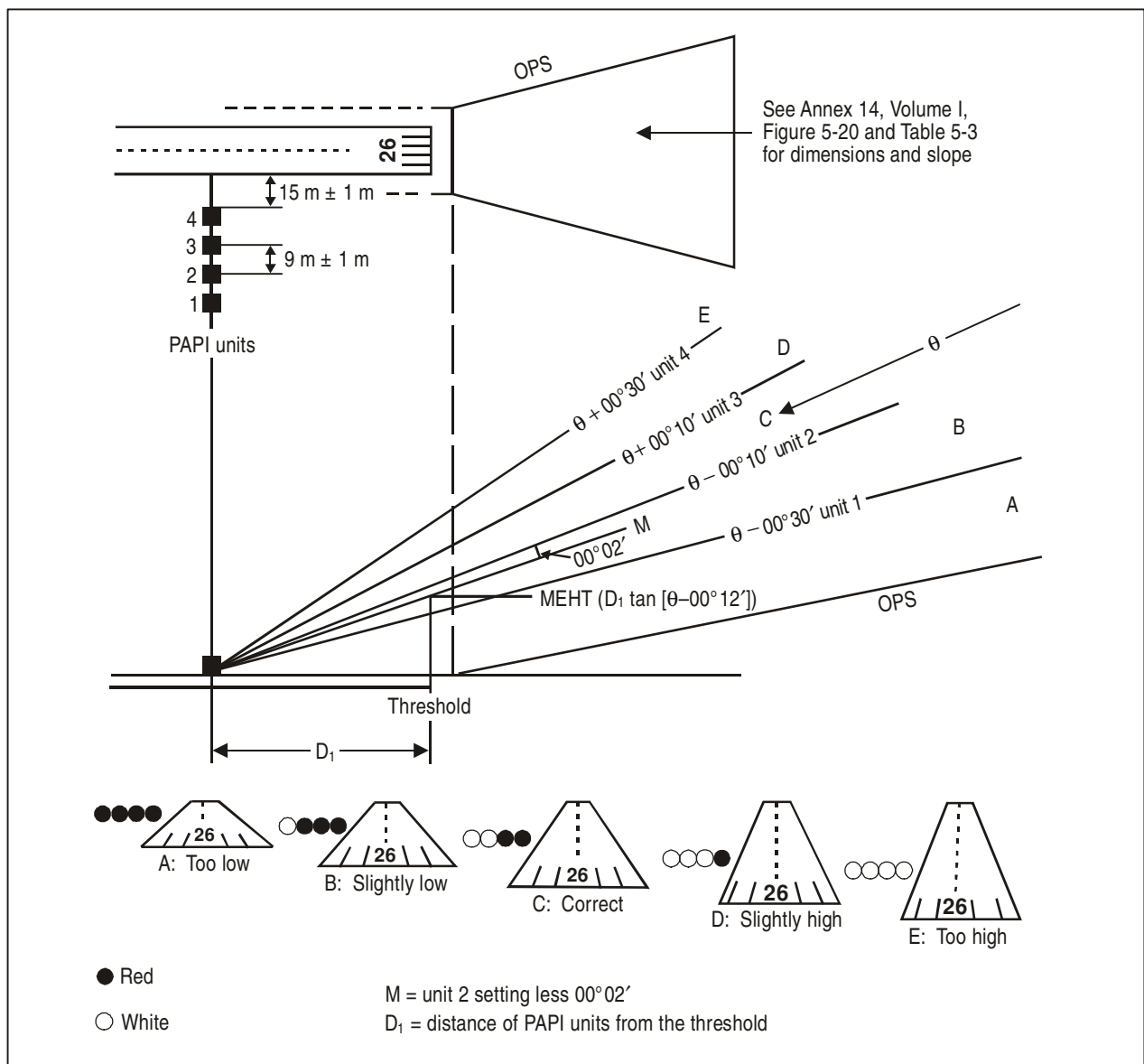

Figure 8-6. The arrangement of the PAPI units and the resulting display

8.3.5 The PAPI system comprises a four-unit wing bar located in a line at right angles to the runway. The unit nearest the runway is set higher than the required approach angle, with progressive reduction in the setting of the units farther outboard. The normal difference between the setting angles is 20 minutes of arc. This value may be varied where PAPI is used in conjunction with non-visual guidance (see

8.3.23) and where approach angles are steeper than 4 degrees (see 8.3.37 and 8.3.38).

8.3.6 The APAPI system comprises a two-unit wing bar located in a line at right angles to the runway. For approach angles up to 7 degrees, the unit closer to the runway is set 15 minutes higher than the required approach

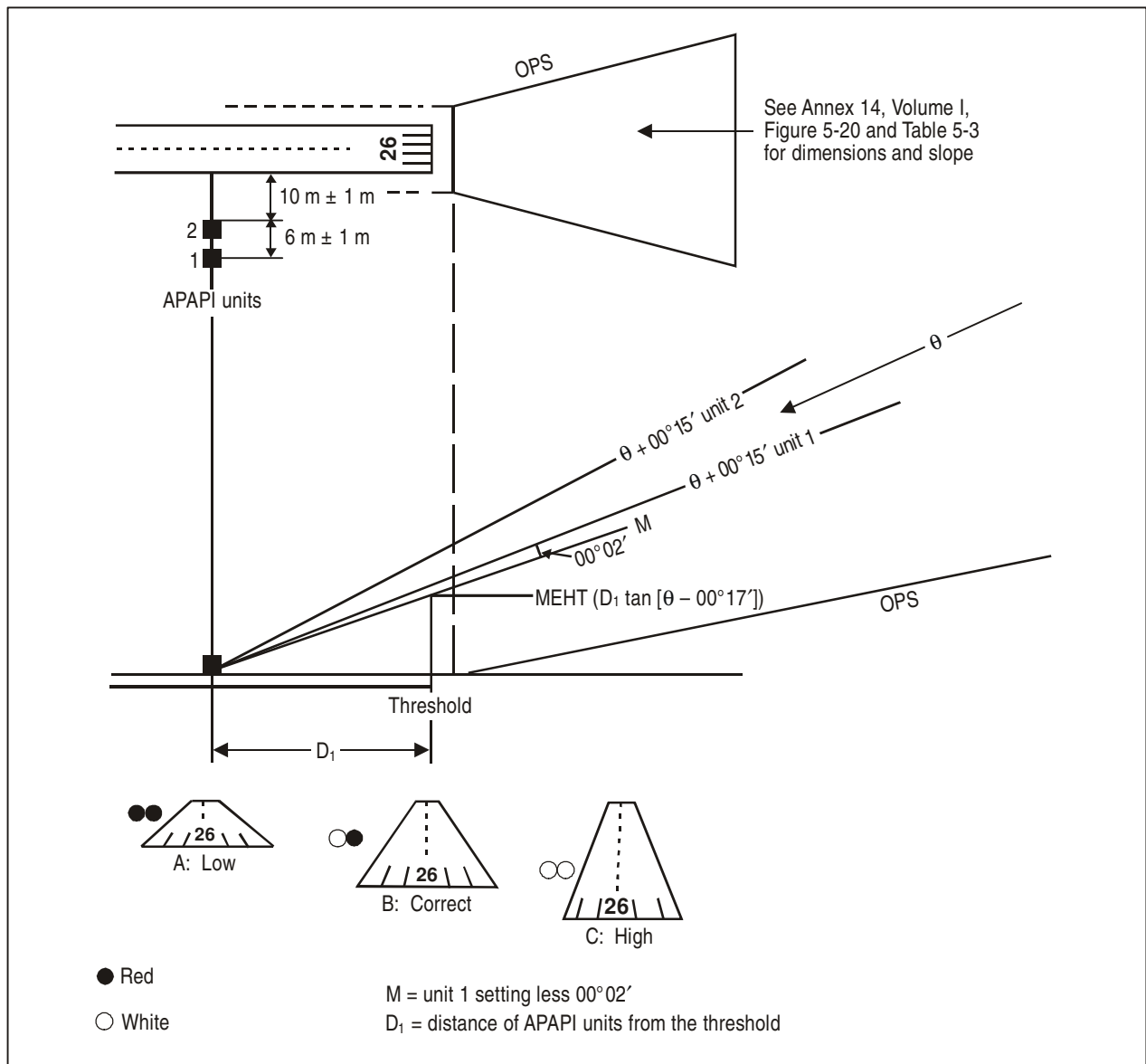

Figure 8-7. The arrangement of the APAPI units and the resulting display

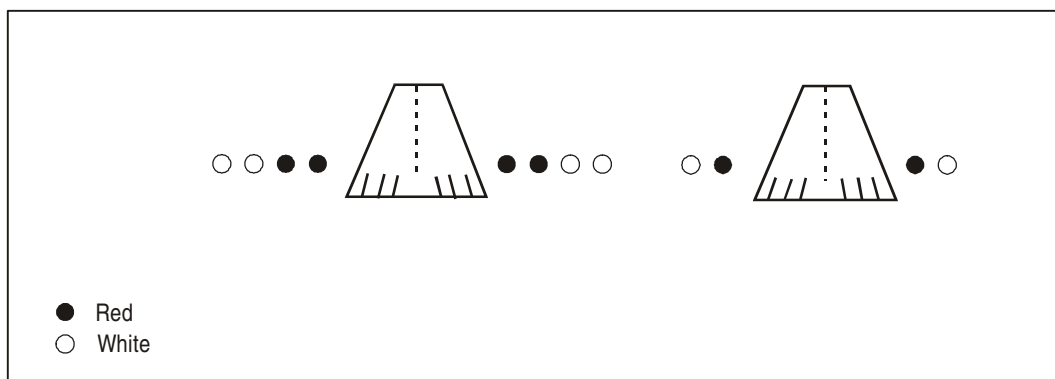

Figure 8-8. PAPI and APAPI units on both sides of a runway

angle and the unit farther from the runway is set 15 minutes lower than the required approach angle. For approach angles greater than 7 degrees, the unit closer to the runway is set 30 minutes higher than the required approach angle and the unit farther from the runway is set 30 minutes lower than the required approach angle.

The characteristics of PAPI and APAPI units

Type of signal

8.3.7 Units producing a light signal, the lower half of which is red and the upper half of which is white, are employed in the PAPI and APAPI systems. The optical principle of these units is shown in Figure 8-9.

Equipment specifications

8.3.8 The transition between the red and white signals should appear to be virtually instantaneous when viewed from ranges in excess of 300 m. Equipment specifications for PAPI and APAPI systems, therefore, should define not only the overall isocandela diagram and the signal colour coordinates of the red and white sectors but also the sharp transition characteristic.

8.3.9 Units which have been found to give a satisfactory sharp transition have a transition zone not greater than 3 minutes of arc in depth, at azimuth angles up to 8 degrees either side of the centre of the beam, expanding to no greater than 5 minutes 15 degrees either side of the centre of the beam.

Setting angles

8.3.10 During manufacture, the centre of the plane of transition is aligned precisely with the unit's horizontal axis, which is the setting angle datum (Figure 8-9). The unit setting angle and the beam elevation are therefore the same and can be set or checked using a clinometer or an equivalent means of angular measurement.

Brilliance

8.3.11 Annex 14, Volume I, Appendix 2, Figure 2.23, details the intensity distribution of PAPI and APAPI light units for a width of 8 degrees horizontally and 5 degrees vertically, either side of the centre of the beam. This diagram details the central part of the beam only. The light units normally used in PAPI and APAPI systems should have a horizontal width of around 30 degrees (i.e. 15 degrees on either side of the centre of the beam) and a proportionate vertical width to ensure that the system can provide the necessary guidance for all operations. Up to five brilliance settings in the range 100 to 1 per cent may be needed depending on the output of the units, operating conditions and the aerodrome environment.

Frangibility and blast resistance

8.3.12 The units should be secured to their bases by means of weak links so that, if an aircraft collides with a unit, the unit will be carried away.

8.3.13 The units should be designed to minimize susceptibility to jet blast.

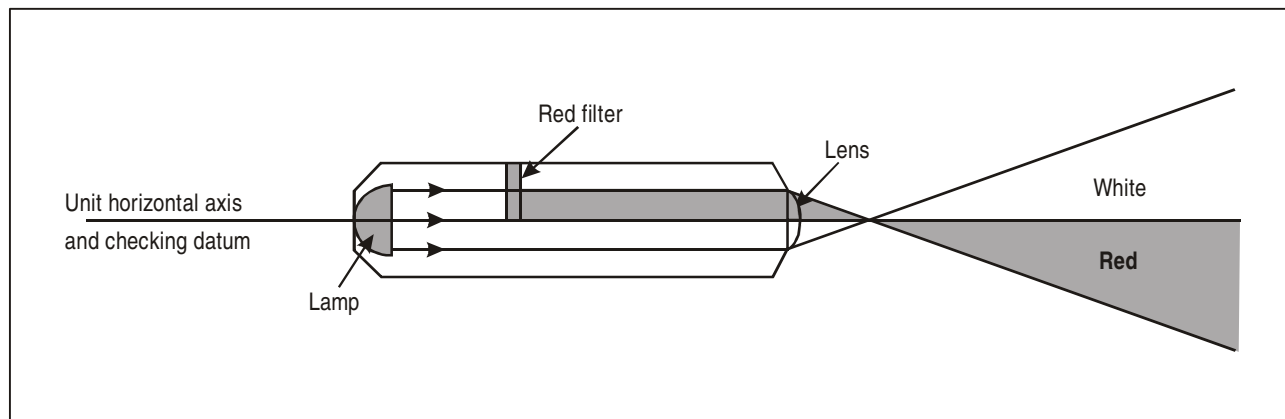

Figure 8-9. PAPI light unit

Resistance to foreign matter

8.3.14 Units should be designed to resist the ingress of foreign matter.

Condensation and ice

8.3.15 Heater elements (50 to 150 W) may be needed to prevent the formation of condensation and ice on the lenses of light units. Operation of light units at a lower power setting (20 W per lamp) when the unit is not in use has also been shown to be a satisfactory method of prevention. Units which do not have some means of keeping the lens glasses warm need a brief full-intensity warm-up period before use to disperse condensation or remove ice from the lenses. The choice of preventative measurements should be matched to the operational circumstances.

Initial flight inspection

8.3.16 A flight inspection of a new installation should be undertaken by the competent authority to confirm the correct operation of the system. The inspection should include checks of range, setting angles, brilliancy control and compatibility with the precision instrument glide path (if provided).

Routine inspection

8.3.17 The initial set-up will be accomplished either by the manufacturer's agent or under strict compliance with the manufacturer's installation instructions. Thereafter the

competent authority should establish a reasonable interval between ground checks. It will be necessary to ground check the units more often on sites where the ground is less stable or where extremes of weather may result in movement of the bases. In many circumstances a monthly alignment check of the setting angles is adequate.

Method of checking

8.3.18 Individual unit setting angles are checked by use of a clinometer, or equivalent means of angular measurement, in accordance with the manufacturer's instructions. Errors in excess of one minute of arc should be corrected. A visual comparison between all the units in the system set at the same angle may be used to identify a unit in which there is a misalignment between the optical system and the datum plate. The cause of any misalignment of this nature should be ascertained and corrected before any adjustment is made to the setting angles.

General condition

8.3.19 A daily check should be made of each unit to ensure that:

- a) all lamps are lighted and illuminated evenly;
- b) no evidence of damage is apparent;
- c) the change from red to white is coincident for all elements in a unit; and
- d) the lenses are not contaminated.

Distance from threshold

8.3.20 The optimum distance of PAPI/APAPI from the runway threshold is determined by:

- a) the requirement to provide adequate wheel clearance over the threshold for all types of aircraft landing on the runway;
- b) the operational desirability that PAPI/APAPI is compatible with any non-visual glide path down to the minimum possible range and height; and
- c) any difference in elevation between the PAPI/APAPI units and the runway threshold.

8.3.21 The distance of the PAPI/APAPI units from the threshold may have to be modified from the optimum after consideration of:

- a) the remaining length of runway available for stopping the aircraft; and
- b) obstacle clearance.

Wheel clearance and minimum on-slope eye height

8.3.22 Annex 14, Volume I, Chapter 5, Table 5-2, details the wheel clearances over threshold for PAPI and APAPI for four aircraft eye-to-wheel height groups. Wheel clearance over the threshold is related to the most demanding amongst the aircraft regularly using the runway. Where practicable, the desired wheel clearances shown in column 2 of the table should be used. The final location of the units is determined by the relationship between the approach angle, the difference in levels between threshold and the units, and the minimum eye height over the threshold (MEHT). The angle M used to establish the MEHT is 2 minutes of arc less than the setting of the unit which defines the lower boundary of the on-slope indication (i.e. unit no. 2 for PAPI and unit no. 1 for APAPI).

Harmonization of PAPI/APAPI with ILS or MLS

8.3.23 It is operationally desirable that PAPI/APAPI is sited so that its on-slope signal will coincide with that for the ILS glide path or the MLS minimum glide path down to the minimum range from the system. The variables that need to be considered are covered in 8.3.24 and 8.3.25.

Fluctuations of the ILS glide path angle

8.3.24 For a nominal glide path angle ϕ , Annex 10, Volume I, specifies a tolerance of ± 0.075 for an ILS Category I or II, and ± 0.040 for an ILS Category III, the systems being serviceable within these limits. For a 3-degree glide path, therefore, ± 13.5 minutes are allowed for ILS Categories I and II and ± 7.2 minutes for Category III. The standard PAPI differential settings give a glide slope of ± 10 minutes, which may not coincide with variations in the nominal angle of the ILS glide path. Where the ILS glide path is found to be consistently different from its nominal setting by 5 minutes of arc or more, the PAPI should be set for the achieved ILS glide slope angle rather than the nominal angle.

Eye-to-aerial heights

8.3.25 Eye-to-aerial values for aeroplanes in the approach attitude, based on data supplied by aircraft manufacturers, are included in Appendix 6. Depending on the position of the PAPI system in relation to the effective origin of the ILS/MLS glide path, the eye-to-aerial value for a particular aircraft type will affect the extent to which harmonization can theoretically be achieved. Harmonization can be enhanced by widening the on-course PAPI sector from 20 minutes to 30 minutes of arc.

Correction of PAPI/APAPI location for runway and other slopes

8.3.26 Where there is a difference in excess of 0.3 m between the elevation of the runway threshold and the elevation of the no. 2 unit of the PAPI or the no. 1 unit of the APAPI at the nominal distance from the threshold, it will be necessary to displace the PAPI/APAPI from its nominal position. This distance will be increased if the proposed site is lower than the threshold and will be decreased if it is higher. The required displacement is determined by multiplying the difference in level by the cotangent of angle M in Figures 8-6 and 8-7.

8.3.27 PAPI/APAPI units should be the minimum practicable height above the ground and not normally above 0.9 m. All units of a wing bar should ideally lie in the same horizontal plane; however, to compensate for cross fall and still meet the criteria for maximum height and to avoid differences in levels of more than 5 cm between adjacent units, a lateral gradient not greater than 1.25 per cent can be accepted, provided it is uniformly applied across the units.

8.3.28 The obstacle protection surface dimensions and slope are determined from Annex 14, Volume I, Chapter 5, Table 5-3, and the surface (Figures 8-6 and 8-7) examined to confirm the absence of infringements. If there is infringement(s) of the obstacle protection surface, and an aeronautical study indicates that such infringement(s) could affect the safety of operations of aeroplanes, then one or more of the measures detailed in 8.3.31 shall be taken.

The landing distance available

8.3.29 The landing run may be limited, especially at smaller aerodromes, and a reduction in wheel clearance over the threshold may be more acceptable than a loss of landing distance. The minimum wheel clearances shown in column 3 of Annex 14, Volume I, Chapter 5, Table 5-2, may be used in such a situation if an aeronautical study indicates such reduced clearances to be acceptable.

Obstacle considerations

8.3.30 Annex 14, Volume I, Chapter 5, Figure 5-20 and Table 5-3, detail the characteristics of the obstacle protection surfaces of PAPI and APAPI. Since these surfaces have been patterned generally on the lines of the approach surface of the runway, the data collected during the obstacle survey of the latter surface will be useful in determining whether or not objects extend above an obstacle protection surface.

8.3.31 Where an aeronautical study indicates that an object extending above the obstacle protection surface could affect the safety of operations of aeroplanes, then one or more of the following measures shall be taken:

- a) suitably raise the approach slope of the system;
- b) reduce the azimuth spread of the system so that the object is outside the confines of the beam;
- c) displace the axis of the system and its associated obstacle protection surface by no more than 5 degrees;
- d) suitably displace the threshold; or
- e) where d) is found to be impracticable, suitably displace the system upwind of the threshold to provide an increase in threshold crossing height equal to the amount by which the object penetrates the obstacle protection surface.

8.3.32 Where an object, located outside the boundaries of the obstacle protection surface of the system, but within the lateral limits of its light beam, is found to extend above the plane of the obstacle protection surface, and an aeronautical study indicates that the object could adversely affect the safety of operations of aeroplanes, then the azimuth spread of the light beam should be restricted so that the object is outside the confines of the light beam.

Note — Restriction of the azimuth beam spread can easily be achieved by reducing the width of the aperture at the filter. Advice on implementing this modification should be sought from the equipment manufacturer.

Procedure for establishing the distance of the PAPI/APAPI wing bar from the runway threshold

8.3.33 When the required approach angle (normally 3 degrees) and appropriate unit setting angles (typically 2°30' 2°50', 3°10' and 3°30' for a 3-degree PAPI system and typically 2°45' and 3°15' for an APAPI system) have been determined, the parameters mentioned in 8.3.20 et seq. are applied, as follows.

8.3.34 On runways where no non-visual guidance is available, Annex 14, Volume I, Chapter 5, Table 5-2, is first consulted to determine the aeroplane eye-to-wheel group and the wheel clearance to be provided at the threshold. The MEHT, which provides the appropriate wheel clearance over the threshold, is established by adding the approach configuration eye-to-wheel height of the most demanding amongst the aircraft regularly using the runway to the required threshold wheel clearance (see 8.3.22).

8.3.35 The calculation of the nominal position of the PAPI/APAPI is made on the assumption that the PAPI/APAPI units are at the same level as the runway centre line adjacent to them, and this level, in turn, is the same as that of the runway threshold. The nominal distance of the PAPI/APAPI from the threshold is derived by multiplying the required MEHT by the cotangent of the angle M in Figures 8-6 and 8-7, respectively.

8.3.36 If ILS or MLS is provided (see 8.3.23), the PAPI should be sited at or upwind of the effective ILS glide path or MLS minimum glide path origin, the distance depending on the average eye-to-aerial height of aircraft regularly using the runway. The distance upwind of the ILS glide path/MLS minimum glide path origin would be equal to the product of the average eye-to-antenna height of aeroplanes regularly using the runway and the cotangent of the

approach angle. The resulting distance from the runway threshold should not be less than that which provides the minimum threshold wheel clearance detailed in Annex 14, Volume I, Chapter 5, Table 5-2, column 3. Further guidance on this issue is included in Example A.

Variations of PAPI/APAPI differential settings with increasing approach angle

8.3.37 At the steeper angles which may apply to some operations, wider differential settings between the units need to be applied in order to facilitate approach slope capture and flyability.

8.3.38 Differential settings that have been found satisfactory are as follows:

Approach angle	Differential setting angle	
	PAPI	APAPI
2° to 4°	00°20'	00°30'
4° to 7°	00°30'	00°30'
over 7°	01°00'	01°00'

Testing of PAPI/APAPI units

8.3.39 The sharp transition between red and white signals is an essential feature of the PAPI system. Verifi-

cation can be carried out prior to installation either by a comparative method or by the use of laboratory equipment.

8.3.40 Where two units are compared, at a range of at least 2 km, with one unit set at a half degree from the transition zone as a reference red signal, the observed transition of the other unit from red to white should be no greater than 3 minutes of arc in depth, 8 degrees horizontally, either side of the centre of the beam, and no greater than 5 minutes at the edges, 15 degrees horizontally, either side of the centre of the beam.

8.3.41 Using a test facility layout as shown in Figure 8-10, the angular subtense between the angles at which a white and a red signal colour can be measured in a laboratory over a short range at the centre of the beam should not exceed 15 minutes of arc. In addition, the angle between the white signal and a signal lying within the extended red area (shown in Figure 8-11) should not exceed 3 minutes of arc. Within a ½ degree either side of the transition zone, the colour coordinates of the emitted signal should be in accordance with Annex 14, Volume I, Appendix 1, paragraph 2, and the emitted signal at greater angles should not be significantly different. The unit under test should be operated at the rated current for the lamp and focused for normal operation.

Note.— Intensity measurements were made by replacing the ground glass screen and tintometer with a small integrating sphere and photocell.

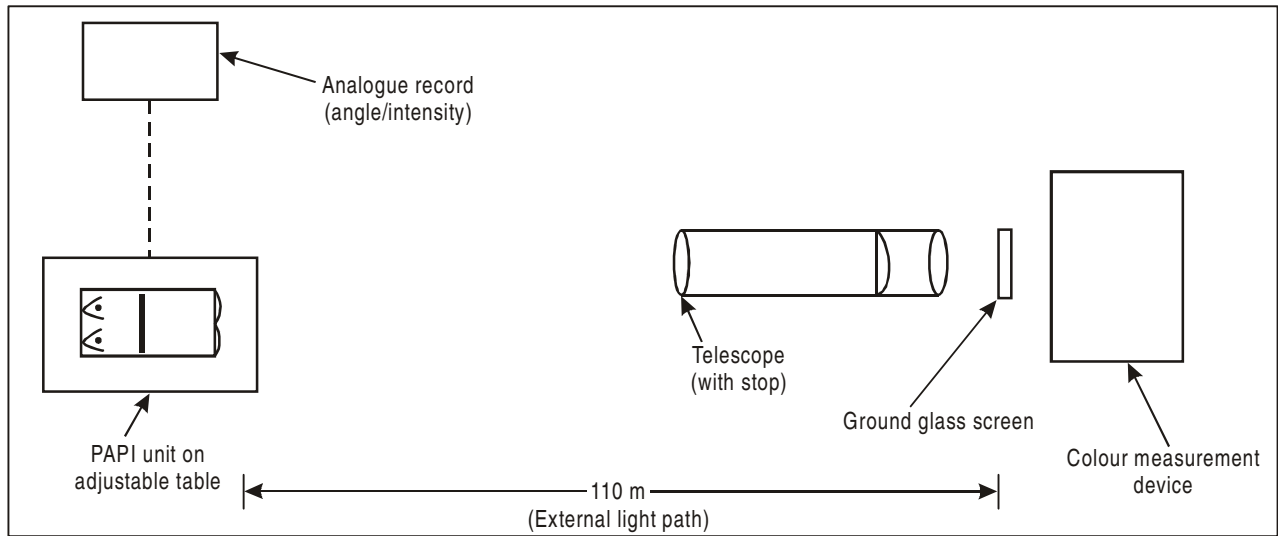

Note.— Intensity measurements were made by replacing the ground glass screen and tintometer with a small integrating sphere and photocell.

Figure 8-10. Layout of test laboratory

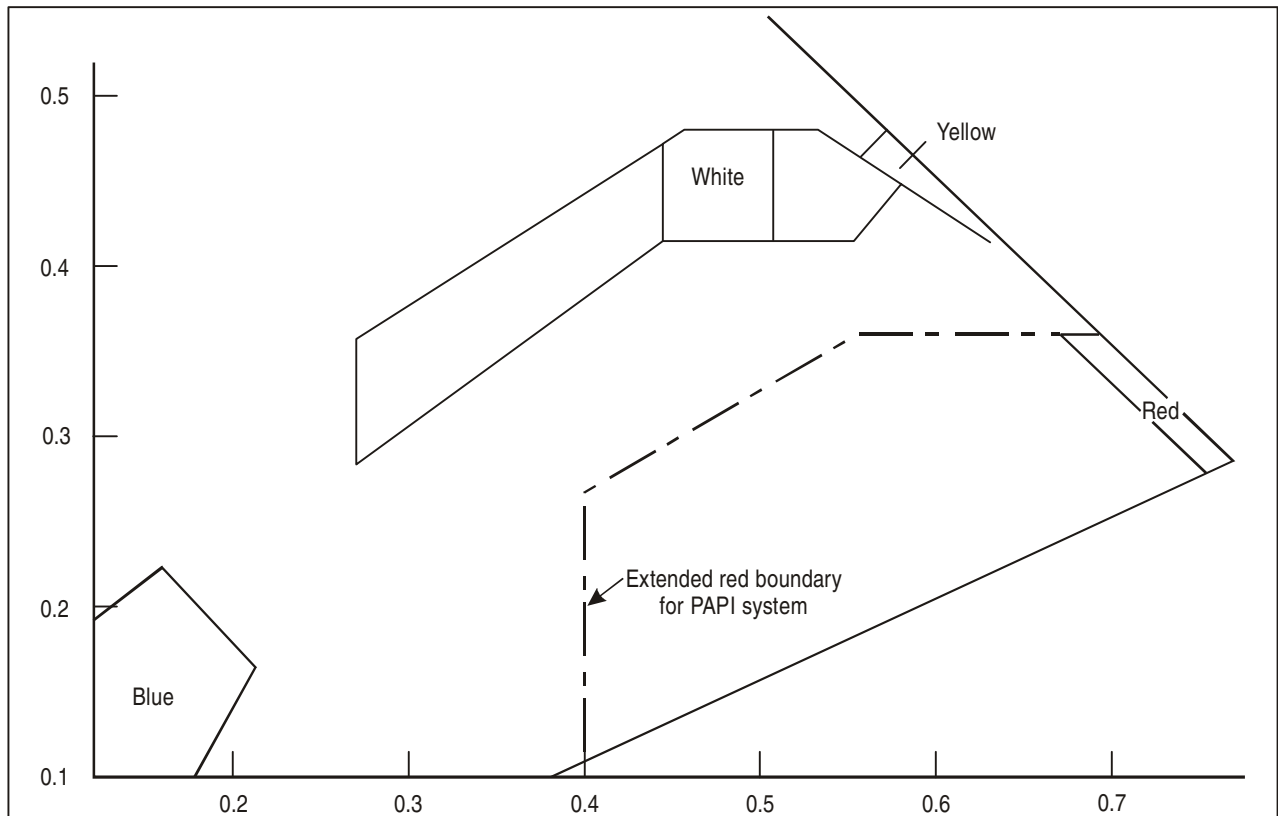

Figure 8-11. Suggested practical boundary for red PAPI

Example A. Calculation for siting PAPI/APAPI on runway with ILS/MLS

1. ILS/MLS reference datum and MEHT.

Siting and installation data for the ILS/MLS will provide the height of the ILS/MLS glide path over the runway threshold (ILS/MLS datum height). For this example, assume ILS/MLS datum height to be 15 m with a 3-degree glide path.

- a) Effective ILS/MLS glide path origin assuming a level runway: $15 \times \cot 3^\circ = 286$ m from threshold.
- b) Average eye-to-aerial height for aircraft using aerodrome, in this case B737 to A300: 1.7 m.
- c) Nominal PAPI position for 1.7 m eye-to-aerial height: $(15 + 1.7) \cot 3^\circ = 318.6$ m.
- d) MEHT: $318.6 \times \tan 2^\circ 43' = 15.1$ m.

Note.— To achieve better harmonization with the ILS/MLS, a 30' on-course sector is used giving a setting for unit 2 of 2°45'. M is therefore 2' of arc less, i.e. 2°43' (see Figure 8-6).

2. Check for wheel clearance.

- a) Eye path to lowest wheel path:

B737	5.18 m
A300	9 m
- b) From Annex 14, Volume I, Chapter 5, Table 5-2:

	<i>Desired wheel clearance</i>	<i>Minimum wheel clearance</i>
B737	6 m	3 m
A300	9 m	6 m

- c) Using MEHT of 15 m, wheel clearance for B737, i.e. better than desired clearance:

$$15 - 5.18 = 9.82 \text{ m.}$$

Wheel clearance for A300, i.e. minimum wheel clearance which in this case is acceptable by local authority:

$$15 - 9 = 6 \text{ m; therefore use MEHT 15 m.}$$

Note.— Should a higher MEHT of 18 m be used to give the desired wheel clearance for A300, the harmonization of PAPI with ILS will be lost further out on the approach for aircraft with smaller eye-to-aerial heights. At

this point, the person siting the PAPI must resolve the priorities between retaining harmonization of the aids and providing the desired wheel clearance.

3. Correct nominal PAPI position for ground height variation (from survey data (see Figure 8-12)).

Ground height at 318.6 m: 63.79 m
 Ground height at threshold: 60.65 m
 Difference: -3.14 m

Move PAPI towards threshold:
 $3.14 \times \cot 2^\circ 43' = 66.33$ m

Amended position of PAPI:
 $318.6 - 66.33 = 252.27$ m

Recheck ground heights:
 Ground height at 318.6 m: 63.79 m
 Ground height at 252.27 m: 63.08 m
 Difference: +0.71 m

Move PAPI away from threshold:
 $0.71 \times \cot 2^\circ 43' = 14.96$ m

New position for PAPI:
 $252.27 + 14.96 = 267.23$ m

Recheck ground heights:
 Ground height at 267.23 m: 63.31 m
 Ground height at 252.27 m: 63.08 m
 Difference: 0.23 m

Difference is less than 0.3 m; therefore, position does not need further refinement.

4. Correct PAPI position for lens height.

Assume height of lens centre above ground level is 0.3 m. Move PAPI towards threshold:

$$0.3 \times \cot 2^\circ 43' = 6.32 \text{ m}$$

Final position of PAPI:
 $267.23 - 6.32 = 260.91$ m or say 261.

5. Back-check MEHT for gross error (see Figure 8-13).

$$\begin{aligned} \text{MEHT: } & 261 \times \tan 2^\circ 43' + (63.21 - 60.65) + 0.3 \\ & = 12.37 + 2.56 + 0.3 \\ & = 15.23 \text{ m.} \end{aligned}$$

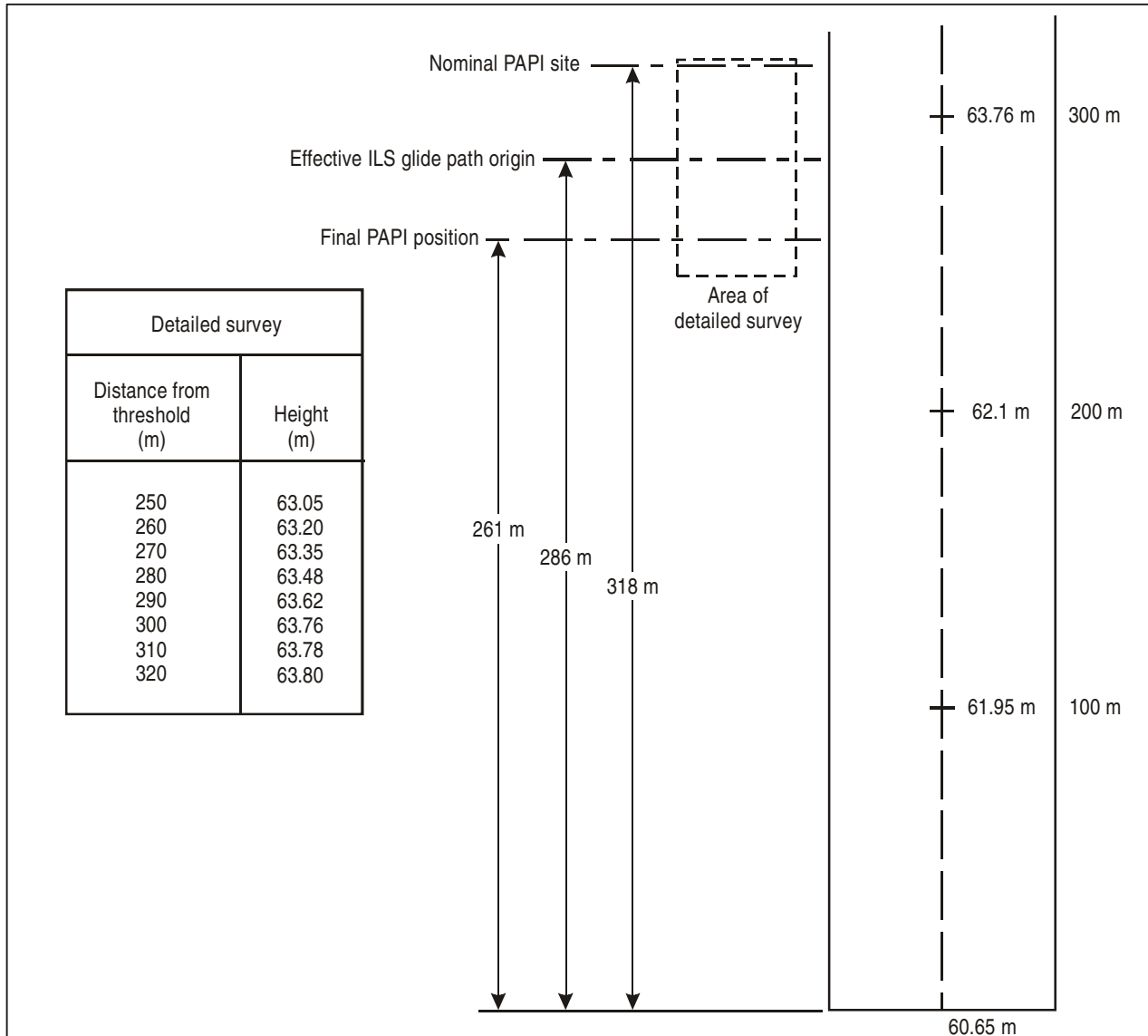

Figure 8-12. Survey data

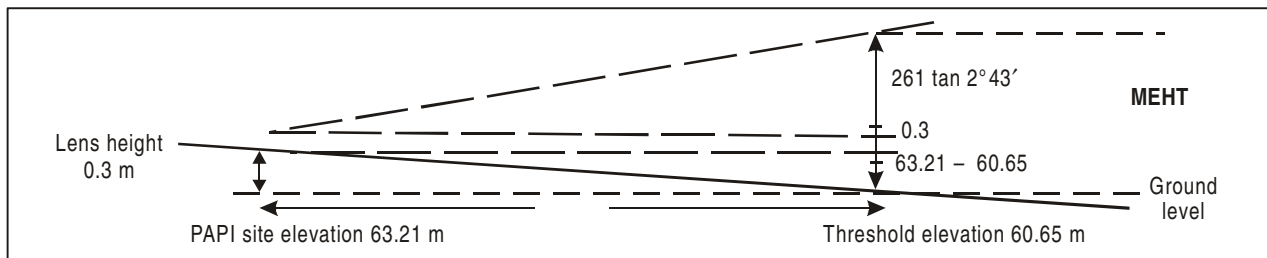

Figure 8-13. MEHT back-check

Chapter 9

Runway and Taxiway Lighting

9.1 INSET LIGHTS

General

9.1.1 It is advisable that inset light fittings have a minimum vertical projection above the surrounding surface consistent with the required photometric characteristics and a minimum bulk above the surrounding surface consistent with presentation of an easy slope in all directions. They should be capable of withstanding the greatest tire pressure and weight of the heaviest type of aircraft expected. Regard should also be paid to the speed that aircraft may attain on that part of the movement area in which inset lights are to be provided; the permissible extent of the projection of a light fitting suitable for marking the centre line of a taxiway (other than a high speed turn-off) would be greater than could be tolerated for a runway inset light. Projections greater than 12 mm may cause damage to the tires where high aircraft speeds and high tire pressures are present.

9.1.2 Snow removal procedures are hampered by inset light fittings. It is not possible to provide flush light fittings that comply with the photometric requirements. However, it is possible to design lights that are compliant but have a projection significantly less than 12 mm.

Installation

9.1.3 Installation of shallow inset touchdown zone lights and shallow inset runway centre line lights is accomplished by drilling a hole into existing pavement slightly greater in depth than the fitting. Sealant material is poured into the prepared hole, and the fitting is installed by means of a jig or holding device to ensure correct vertical and lateral alignment. Slots or saw kerfs are provided in the existing pavement to connect the lights. These extend to the runway edge. Wires or conduits are laid into the slots which are then filled with sealant material.

9.1.4 Installation of deep inset touchdown zone and centre line lights is best accomplished as part of pavement construction. For touchdown zone lights, a properly sized hole is left open during the initial paving to accommodate the subsequent installation of the inset bases for a barrette. A rigid conduit is placed below the pavement from the edge of the runway and connected to the inset bases. The inset bases are held at the proper elevation and alignment by means of a jig. The open area is then backfilled with concrete pavement. Wire is drawn through the conduit into the bases, connections are made to insulating transformers, and the removable top fitting containing the lamp is bolted onto the inset base to complete the installation. Techniques for installation of deep base cans in existing concrete pavement are also available.

Measuring the temperature of inset lights

Effect of inset lights on tires

9.1.5 Tests have been undertaken by a number of States to measure the temperature of inset lights and the effect on tires both in contact with and close to the lights. Results have indicated that where the tire is in contact with an inset light, temperatures of up to 160°C for a short period of time (i.e. about 10 minutes) have not caused any significant damage to the tire. Also the radiant energy in the light beam from inset lights can give rise to high tire temperatures, but again, to date, it has not been found to cause any significant detrimental effects on the tire.

9.1.6 One reason that the heat from inset lights has not been a problem is that the high temperature on the top of the inset light is very localized, i.e. usually in the centre of the top of the inset light. There is generally a large temperature gradient between the centre and the edge of an inset light so that the total energy absorbed by the tire from the inset light is relatively small.

Difference between field and laboratory tests

9.1.7 Several States have undertaken field studies to investigate these effects. Additionally, laboratory-based studies where the tests have been made in a draught-free, heat test chamber have been conducted. It is significant that the laboratory temperature measurements are considerably higher than those experienced in the field. This fact is well known because the influence of any air movement has a considerable cooling effect on the object being investigated.

Recommended temperature limits

9.1.8 Based on current knowledge, the two sets of conditions under which measurements can be made, field and laboratory, necessitate stipulating figures appropriate to each. The laboratory-based measurements will be repeatable whereas the field measurements will be somewhat variable. In view of the limited knowledge available concerning the effects of very high ambient temperatures combined with strong solar radiation on tires, runway surfaces, inset lights, etc., it is suggested that for these areas, individual recommendations may be required and possibly some operational safeguards may be necessary.

Field conditions

9.1.9 For tests undertaken on installed inset lights, the temperature at the interface between the aircraft tire and the inset light should not exceed 160°C during 10 minutes of exposure, whether by conduction or radiation. The inset light should be operated at full intensity for a sufficient time prior to the measurement for the light to reach a temperature approximating thermal equilibrium. This time would probably be at least two hours. The measurement should be made using a thermocouple placed between the surface of the tire and the part of the inset light which is heated the most. For some designs of inset lights the temperature at the surface of the tire can be a maximum due to radiant energy in the light beam and therefore a series of measurements may have to be made to ascertain the most critical position.

Laboratory conditions

9.1.10 The following paragraphs provide guidance material on laboratory methods for assessing the temperature of inset lights. They are intended to identify any potential heat damage when a wheel is parked over a light. Tests should be undertaken in a draught-free, heat test

chamber where the temperature of the ambient air is 30°C. Before the measurements are taken, the inset light should be operated at full intensity for a sufficient length of time for the light to reach a temperature approximating thermal equilibrium. This time would probably be at least two hours.

9.1.11 For tests undertaken under laboratory conditions, it is suggested that the temperature at the interface between the inset light and the tire should be not more than 160°C during 10 minutes of exposure, whether by conduction or radiation.

9.1.12 For these tests the inset light should be placed in a box of the minimum dimension shown in Figure 9-1. The box could be either:

- a) concrete, with the inset light bonded into the concrete in the way recommended by the manufacturer; or
- b) sand-filled.

It should be noted that the sand-filled box will give rise to the more onerous conditions for testing due to the low thermal conductivity of the sand.

9.1.13 In most cases the measurement should be taken when the tire is directly on the inset light and the thermocouple lies between the tire and the hottest part of the inset light. However, for some designs of inset lights, the temperature at the surface of the tire can be a maximum due to radiant energy in the light beam and therefore a series of measurements should be made to ascertain the critical position. The tire should be sufficiently loaded so that during the test the contact between the tire and the inset light is properly representative of service conditions.

9.2 TAXIWAY EDGE LIGHTS — “SEA OF BLUE” EFFECT

9.2.1 At many aerodromes, the concentration of taxiway edge lights in the operational area often results in a confusing mass of blue lights commonly referred to as a “sea of blue”. In some cases, this can result in pilots finding it difficult to correctly identify the taxiway boundaries. This problem particularly occurs in complex taxiway layouts with small radius curves.

9.2.2 This problem can be removed by the use of taxiway centre line lights, thereby eliminating the need to

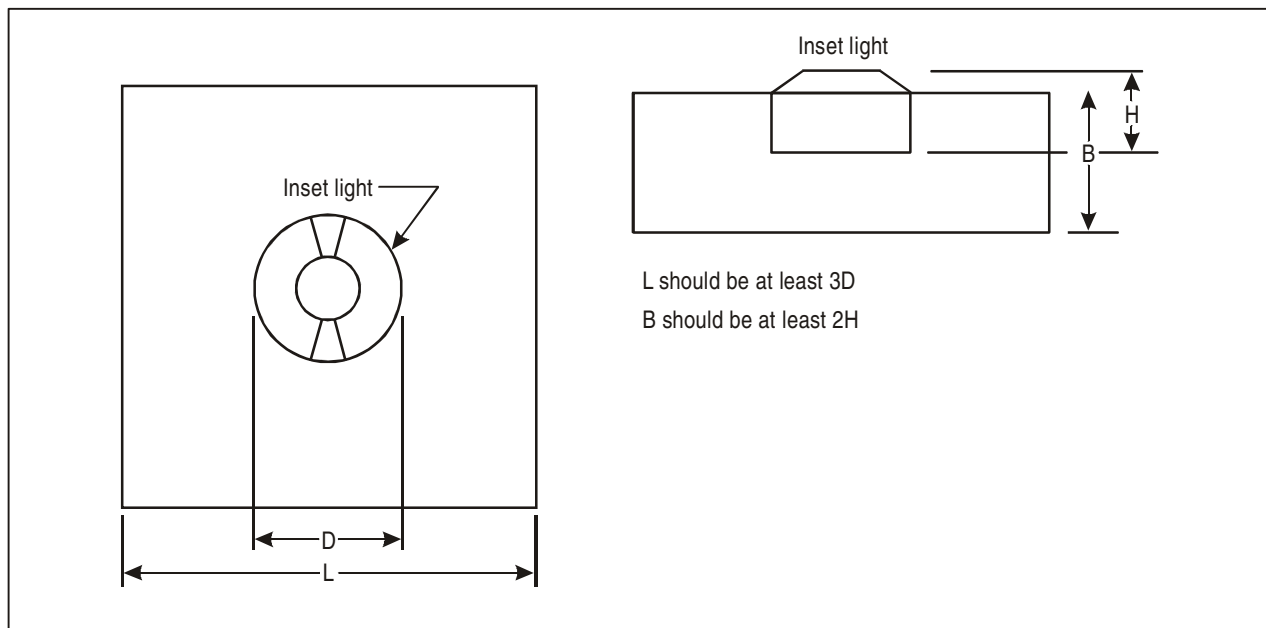

Figure 9-1. A typical container used for the temperature measurement of inset lights

install edge lights in much of the taxiway system. Edge lights are normally still installed on curved portions of taxiways, at taxiway intersections and at taxiway/runway intersections.

9.3 EXIT TAXIWAY LIGHTING

9.3.1 The Annex 14, Volume I specifications for runway centre line lights and taxiway centre line lights have been amended to include lateral tolerances of 60 cm and 30 cm, respectively. This was done to overcome problems in installing the lights along the centre line due to the presence of a pavement joint, e.g. longitudinal construction joint of a cement concrete runway or taxiway. Nevertheless, where runway centre line lights and taxiway centre line lights are located in proximity, e.g. exit taxiways, there is a need to ensure that the lights are separated by at least 60 cm to avoid merging of the signals. To this end, the specifications for taxiway centre line lights on rapid exit taxiways and on other exit taxiways have also been amended. The purpose of this section is to explain how runway and taxiway centre line markings and lights should be displayed/installed at runway/taxiway intersections under different conditions to comply with the new requirements.

9.3.2 It is important to note that the specifications still envisage the display of the runway centre line marking and taxiway centre line marking along the centre line of the runway and taxiway, respectively. Where the lights are located on the marking, care should be taken to avoid contamination during any repainting of the marking.

9.3.3 Of the four conditions illustrated in Figure 9-2, condition a) is the simplest. The runway consists of a flexible pavement (e.g. asphaltic concrete), and consequently there is no difficulty in installing the runway centre line lights along the centre line of the runway or the exit taxiway centre line lights on the exit taxiway centre line marking.

9.3.4 Condition b) represents a cement concrete runway with a longitudinal joint along the runway centre line. As a result, the runway centre line lights are offset by 60 cm. On the other hand, there is no difficulty in locating the exit taxiway centre line lights on the exit taxiway centre line marking. It is significant to note that the runway centre line lights are offset on the opposite side to the exit taxiway.

9.3.5 Condition c) represents a case where exit taxiways are located on both sides of a runway which consists of a flexible pavement, e.g. asphaltic concrete. The

Figure 9-2. Marking and lighting of runway/taxiway intersections

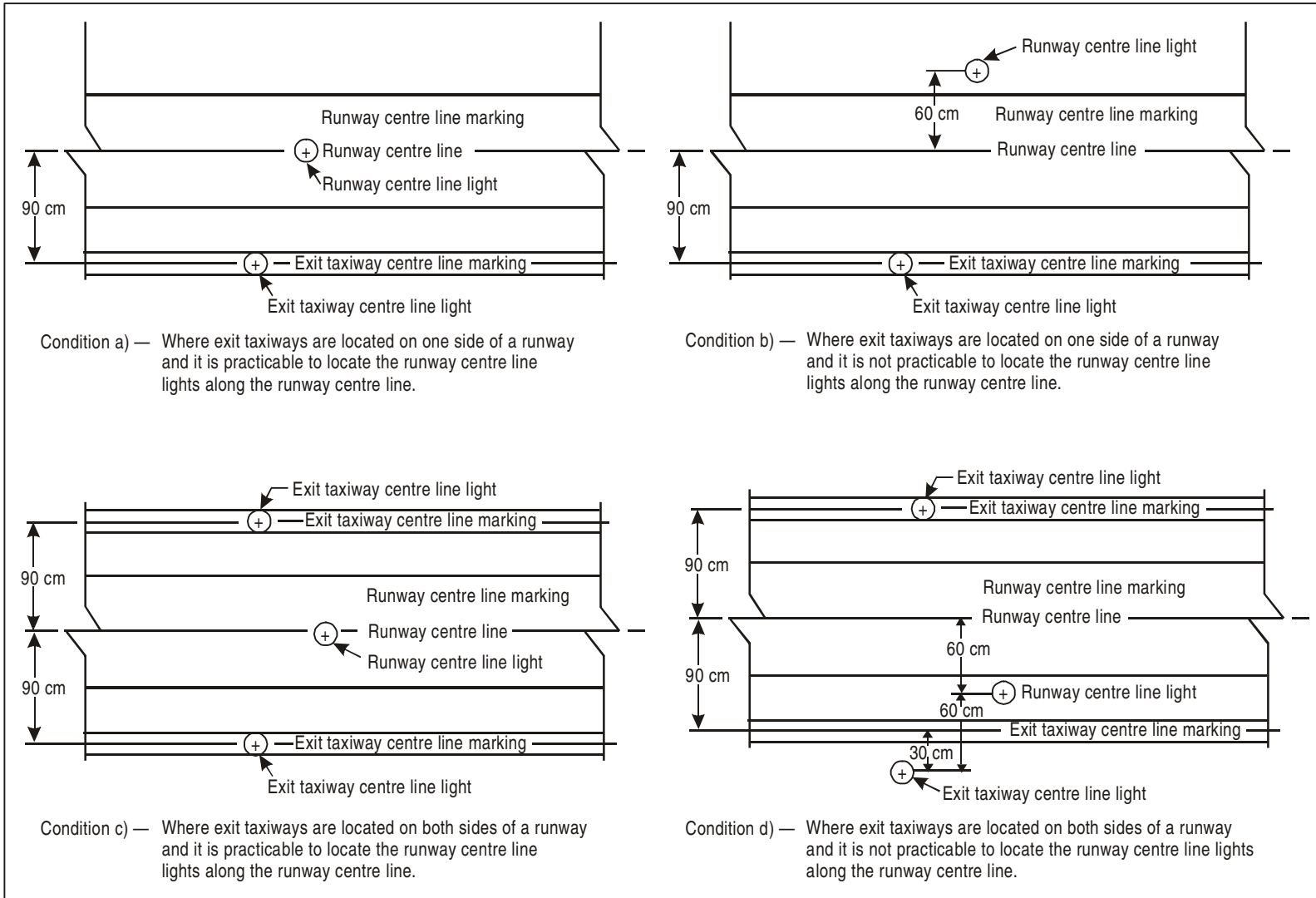

runway centre line lights are located along the runway centre line and the exit taxiway centre line lights on the exit taxiway centre line markings.

9.3.6 Condition d) represents a case where exit taxiways are located on both sides of a cement concrete runway. The runway centre line lights are offset by 60 cm due to the presence of a longitudinal joint along the runway centre line.

This in turn necessitates the offsetting of the exit taxiway centre line lights on one side by 30 cm to maintain a 60-cm separation between the runway centre line lights and exit taxiway centre line lights. The exit taxiway centre line lights on the other side are located on the exit taxiway centre line marking. It is significant to note that the runway centre line lights should be offset on the opposite side to the majority of exit taxiways.

Chapter 10

Surface Movement Guidance and Control Systems

10.1 GENERAL

10.1.1 The term “surface movement guidance and control (SMGC) system” stands for a system of aids, facilities and procedures designed to meet the requirements for guidance and control of surface traffic consistent with the particular operational conditions at a particular aerodrome. All aerodromes have some form of SMGC system.

10.1.2 An SMGC system comprises an appropriate combination of visual aids, non-visual aids, radiotelephony communications, procedures, control and information facilities. Systems range from the very simple at small aerodromes with light traffic operating only in good visibility to the complex at large and busy aerodromes with operations in very low visibility conditions. The purpose of this chapter is to identify those visual aids which are used in an SMGC system. For guidance on all other aspects of SMGC systems, readers are advised to refer to the *Manual of Surface Movement Guidance and Control Systems (SMGCS)* (Doc 9476).

10.1.3 The main reason for providing an SMGC system is to enable an aerodrome to cope safely with the ground movement demands placed on it under specified operational conditions. The system should therefore be designed to prevent collisions between aircraft, between aircraft and ground vehicles, between aircraft and obstacles, between vehicles and obstacles and between vehicles. In the simplest case, i.e. in good visibility conditions and with light traffic, this objective may be achieved by a system of visual signs and a set of aerodrome traffic rules. In more complex situations, particularly under poor visibility conditions and/or heavy traffic, a more elaborate system will be required.

10.1.4 Basic SMGC systems, as described in the *Manual of Surface Movement Guidance and Control Systems (SMGCS)*, are not always capable of providing the necessary support to aircraft operations in order to maintain the required capacity and safety levels, specifically under low visibility conditions. An advanced surface movement

guidance and control system (A-SMGCS) is expected to provide adequate capacity and safety in relation to the specific weather conditions, traffic density and aerodrome layout through the use of modern technologies and a high level of integration between the various functionalities. Availability and development of new technologies, including automation capabilities, makes it possible to increase aerodrome capacity in low visibility and on complex and high-density aerodromes.

10.1.5 SMGC systems were developed on the basis of the “see-and-be-seen” principle being adequate to maintain separation between aircraft and/or vehicles on the movement area. Progressive increases in traffic levels, difficulties in navigating on taxiways in complex aerodrome layouts and the erosion of the “see-and-be-seen” principle by low visibility conditions are factors that can lead to incidents and accidents including runway incursions. As indicated above, to address these problems enhancements to the basic SMGC systems are required. The “ICAO Operational Requirements for Advanced Surface Movement Guidance And Control Systems (A-SMGCS)”, published as an Attachment to State Letter SP 20/1-98/47 dated 12 June 1998, are intended to stimulate and guide these enhancements in a progressive manner.

10.2 OPERATIONAL REQUIREMENTS

10.2.1 The level of the SMGC system that is provided at an aerodrome should be related to the operational conditions under which it is intended that the system shall operate. It is important to recognize that a complex SMGC system is not needed and is uneconomic at aerodromes where visibility, aerodrome layout complexity and traffic density, separately or in combination, do not at present cause problems for the ground movement operations of aircraft and vehicles. However, failure to provide an SMGC system with a capacity properly matched to the operational demands at an aerodrome will restrict the movement rate and may affect safety.

10.2.2 All SMGC systems have four basic functions:

- a) *guidance*, which consists of the facilities, information and advice that are necessary to provide continuous, unambiguous and reliable information to pilots of aircraft and drivers of vehicles to keep their aircraft or vehicles on the surfaces and assigned routes intended for their use;
- b) *routing*, which is the planning and assignment of a route to individual aircraft and vehicles to provide safe, expeditions and efficient movement from the current position to the intended position;
- c) *control*, which is the application of measures to prevent collisions and runway incursions thereby ensuring safe, expeditious and efficient ground movements; and
- d) *surveillance*, which provides identification and accurate positional information on aircraft, vehicles and other objects.

10.2.3 Guidance and control of the many vehicles that operate in stand areas present special problems in relation to the level of the SMGC system that is required. These can be dealt with by using the concept that the role of any particular stand changes with time. When an aircraft is stationary on a stand with engines running or an aircraft is moving on the stand or an aircraft is approaching the stand, then the stand is part of the movement area and appropriate SMGC system provisions are required. If a stand is occupied but the aircraft engines are not running or if the stand is vacant and not being approached by an aircraft, then the stand is not at that time part of the movement area, and SMGC system provisions are not required.

10.2.4 The tendency in A-SMCGS implementation is towards a reduction in the voice communications workload, an increase in the use of surface guidance aids and a greater reliance on avionics in the cockpit to help guide the pilot to and from the runway. ATC surveillance of aircraft and vehicles will make greater use of electronic aids, and automation will play an increasing role in the monitoring of the dynamics of surface operations.

10.2.5 The “ICAO Operational Requirements for A-SMGCS” should be consulted whenever a new implementation of an SMGC system is planned, to ensure compliance with the appropriate A-SMGCS concepts. The parameters that identify the necessary level of provision, based on visibility conditions, traffic density and aerodrome layout, are clearly set out in those Requirements.

Note.— A-SMGCS is a progressive enhancement of existing SMGC systems, providing greater capabilities as they become justified by operational considerations. It is not an alternative system that requires decommissioning of existing SMGC system implementations.

10.3 THE ROLE OF VISUAL AIDS

10.3.1 Visual aids have a role in the guidance, routing and control functions of SMGC systems. There are a number of high-level goals in the design of any system that relate specifically but not always exclusively to the provision of visual aids. These are:

- a) an SMGC system should be able to accommodate all aircraft and authorized vehicles;
- b) the guidance function should support safe operations on the aerodrome considering the visibility conditions, traffic density and aerodrome layout;
- c) pilots and vehicle drivers should be able to follow their assigned routes in a continuous, unambiguous and reliable way;
- d) visual aids should be an integral component of the surface movement system; and
- e) an SMGC system should be implemented in a modular form to allow for system growth as the operational situation changes.

10.3.2 When visibility conditions permit a safe, orderly and expeditious flow of authorized movements by visual means, the guidance function of an SMGC system will be based primarily on standardized visual aids using markings, lighting and signs. When visibility conditions are sufficient for pilots to taxi by visual reference alone, but the sole use of conventional visual aids restricts the expeditious flow of authorized movements, additional visual or non-visual systems may be needed to support the guidance function. Any additional visual aids that are developed should be standardized in accordance with ICAO practices.

10.3.3 Once a route has been assigned, then a pilot or vehicle driver requires information to follow that route. Visual aids provided for guidance indicate where an aircraft or vehicle can be safely manoeuvred. Selectively switchable taxiway centre line lights and/or variable message signs are possible means of enabling routes to be uniquely designated.

10.3.4 Pilots and vehicle drivers always require some form of routing and guidance information. At many aerodromes visual aids will also be required to be part of the control function. Surveillance information is needed to support this service.

10.3.5 The surveillance function of an SMGC system depends on the use of sensors to provide the necessary identification and positional information related to all aircraft and vehicles. In the most basic form, visual surveillance by ATC enables the correct visual aids to be activated by ATC personnel within the control tower. In the more sophisticated systems that may be required at busy, complex aerodromes and in low visibility conditions, surveillance derived from sensors such as radar, satellite-based navigation systems, inductive loops or laser, microwave and infrared detectors may be used as an input to the routing, guidance and control functions. The sensors may be used singly or the data from a number of different sensors may be fused to provide an optimized identification and location solution throughout the movement area. The performance requirements for the surveillance function are at their most demanding when the information is to be used as an input to the control function to maintain separation standards between aircraft.

10.4 VISUAL AID COMPONENTS OF AN SMGC SYSTEM

Visual aids for guidance

10.4.1 The following aids are used to provide the guidance function. The circumstances under which each one is applied are described in the relevant “Application” paragraphs in Annex 14, Volume I, Chapter 5.

Runway centre line marking

Related specification: Annex 14, Volume I, Chapter 5.

Taxiway centre line marking

Related specification: Annex 14, Volume I, Chapter 5.

Runway-holding position marking

Related specification: Annex 14, Volume I, Chapter 5.

Intermediate holding position marking

Related specification: Annex 14, Volume I, Chapter 5.

Aircraft stand markings

Related specification: Annex 14, Volume I, Chapter 5.
Guidance material: Chapter 2 of this manual.

Signs

Related specification: Annex 14, Volume I, Chapter 5.
Guidance material: Chapter 11 of this manual.

Visual aids for denoting restricted use areas

Related specification: Annex 14, Volume I, Chapter 7.

Runway edge lights (night)

Related specification: Annex 14, Volume I, Chapter 5.

Taxiway edge lights (night)

Related specification: Annex 14, Volume I, Chapter 5.
Guidance material: Chapter 9 of this manual.

Runway centre line lights

Related specification: Annex 14, Volume I, Chapter 5.

Taxiway centre line lights

Related specification: Annex 14, Volume I, Chapter 5.
Guidance material: Paragraphs 10.4.7 to 10.4.9 of this manual.

Intermediate holding position lights

Related specification: Annex 14, Volume I, Chapter 5.
Guidance material: Paragraph 10.4.13 of this manual.

Stop bars

Related specification: Annex 14, Volume I, Chapter 5.
Guidance material: Paragraphs 10.4.10 to 10.4.17 of this manual.

Runway guard lights

Related specification: Annex 14, Volume I, Chapter 5.
Guidance material: Paragraphs 10.4.18 to 10.4.26 of this manual.

Visual parking/docking guidance systems

Related specification: Annex 14, Volume I, Chapter 5.
Guidance material: Chapter 12 of this manual.

Monitoring system

Related specification: Annex 14, Volume I, Chapter 8.
Guidance material: *Aerodrome Design Manual*, Part 5.

Visual aids for routing

10.4.2 The selective switching of the lighting aids provided for guidance can indicate specific fixed routes that have been issued for aircraft or vehicle use if required by operational circumstances. Where fixed routes are in use, the same visual aids will be operated for all movements whilst the operational conditions that require such routes

persist. At aerodromes where the routing varies frequently according to operational needs, selective switching of the lighting aids can be used to clearly indicate the issued route for particular movements. To achieve these flexible capabilities, it is necessary for the lighting aids to be selectable in segments that are small enough to meet the objective of clearly indicating the correct route. It is also important that the switching can be done in a timely and accurate manner, since two closely spaced aircraft may have different assigned routes. In situations where it is desired to reduce the workload of ATC, the route switching may be carried out with the aid of a computer-based system once the route to be issued has been verified by the controller.

Visual aids for control

10.4.3 At all aerodromes, visual aids provide guidance information to pilots and vehicle drivers. Routing indication is closely related to the guidance function, and as described above, at many aerodromes routing information will be conveyed by the selective switching of the visual aids. In practice, all SMGC systems provide routing and guidance information through the use of visual aids.

10.4.4 The extent of any control that is applied by an SMGC system depends on the requirements at each aerodrome. Where practicable, the main means of exercising control of movements should be through the use of visual aids.

10.4.5 To achieve this functionality, the visual aids designed for an SMGC system may need to be augmented, but the basic characteristics of the aids remain unchanged. The main augmentations that may be introduced are increased levels of computer-added control of the aids and switching of the lighting in some cases down to the level of individual light units.

10.4.6 The visual aids that may be used to provide a control function are the following:

Signalling lamps

Related specifications: Annex 14, Volume I, Chapter 5; Annex 2, Appendix A.

Surface markings

Related specifications: Annex 14, Volume I, Chapter 5.
Guidance material: Chapter 2 of this manual.

Signs

Related specification: Annex 14, Volume I, Chapter 5.
Guidance material: Chapter 11 of this manual.

Intermediate holding position lights

Related specification: Annex 14, Volume I, Chapter 5.
Guidance material: Paragraph 10.4.13 of this manual.

Stop bars

Related specification: Annex 14, Volume I, Chapter 5.
Guidance material: Paragraphs 10.4.10 to 10.4.17 of this manual.

Runway guard lights

Related specification: Annex 14, Volume I, Chapter 5.
Guidance material: Paragraphs 10.4.18 to 10.4.26 of this manual.

Selectively switchable taxiway centre line lights

Guidance material: Paragraphs 10.4.2 and 10.4.7 to 10.4.9 of this manual.

Road-holding position lights

Related specifications: Annex 14, Volume I, Chapter 5.
Guidance material: Paragraphs 10.4.27 to 10.4.30 of this manual.

Monitoring system

Related specification: Annex 14, Volume I, Chapter 8.
Guidance material: Aerodrome Design Manual, Part 5.

Taxiway centre line lights

10.4.7 The most positive means of providing taxiing guidance is through taxiway centre line lighting. When these lights are also selectively operated, positive control of the routes of taxiing aircraft is provided. Taxiway centre line lighting is particularly effective and often the only means of providing guidance and control in poor visibility conditions. Provided the lights are of adequate intensity, the method can also be effective for day operations.

10.4.8 Where taxiway centre line lights are installed specifically as a component of an A-SMGCS, it may be considered necessary, following a specific study, to use high-intensity taxiway centre line lights in accordance with the recommendations of Annex 14, Volume I. This enhancement is likely to be required if the A-SMGCS guidance and control function is to be applied through visual aids in bright day or very low visibility conditions.

10.4.9 In practice, guidance is provided by switching on only the taxiway centre line lighting on the route to be followed to the aircraft's destination. Multiple routes may be lighted to allow more than one aircraft to taxi at the same time. For greater safety, it is desirable that the system

be so designed electrically or mechanically that it is physically possible to light only one route through a junction at one time. To exercise control, such lighting systems are also equipped with stop bars at junctions, which operate in conjunction with the centre line lights and further indicate to the crossing aircraft when it should stop and when it may proceed.

Stop bars

10.4.10 The use of stop bars is an effective means of controlling ground movements of aircraft and vehicles on the manoeuvring area and will reduce the number of incidents and accidents due to runway incursions. The provision of stop bars requires their control, either manually or automatically, by air traffic services.

10.4.11 Annex 14, Volume I, specifies, as a Standard, that a stop bar shall be provided at every runway-holding position serving a runway when it is intended that the runway will be used in runway visual range conditions less than a value of 550 m, except where:

- a) other appropriate aids and procedures are available to assist in preventing inadvertent incursions of aircraft and vehicles onto the runway; or
- b) operational procedures exist to limit, in runway visual range conditions less than a value of 550 m, the number of:
 - 1) aircraft on the manoeuvring area to one at a time; and
 - 2) vehicles on the manoeuvring area to the essential minimum.

Note.— A runway-holding position is defined as a designated position intended to protect a runway, an obstacle limitation surface, or an ILS/MLS critical/sensitive area at which taxiing aircraft and vehicles shall stop and hold, unless otherwise authorized by the aerodrome control tower.

10.4.12 Annex 14, Volume I, also recommends that a stop bar should be provided at an intermediate holding position when it is desired to supplement markings with lights and to provide traffic control by visual means.

10.4.13 At an intermediate holding position where there is no need for a stop-and-go signal, it is recommended that intermediate holding position lights be provided. In

runway visual range conditions less than a value of 550 m, this provision shall apply as a Standard.

Note.— An intermediate holding position is defined as a designated position intended for traffic control at which taxiing aircraft and vehicles shall stop and hold until further cleared to proceed, when so instructed by the aerodrome control tower.

10.4.14 The specifications for stop bars include a provision for the suppression of the taxiway centre line lights for a distance of 90 m beyond an activated stop bar in the direction that is intended for an aircraft to proceed. When the stop bar is suppressed these inter-linked taxiway centre line lights shall be simultaneously illuminated.

10.4.15 An aircraft that is stationary at a stop bar may require at least 30 seconds to move the 90 m covered by the interlocked taxiway centre line lights. Premature reselection of the stop bar after the issue of a clearance may, particularly in low visibility conditions, result in the pilot having less than the required segment of lighting guidance.

10.4.16 Stop bars shall consist of unidirectional in-pavement lights spaced at intervals of 3 m across the taxiway showing red in the direction of the approach to the runway holding position or the intermediate holding position.

10.4.17 Where stop bars are installed specifically as a component of an A-SMGCS, it may be considered necessary, following a specific study, to use high-intensity stop bars in accordance with the recommendations of Annex 14, Volume I.

Elevated and in-pavement runway guard lights

10.4.18 The provision of runway guard lights is an effective way of increasing the conspicuity of the location of the runway-holding position in visibility conditions above as well as below a runway visual range of 1 200 m. There are two standard configurations of runway guard lights, elevated and in-pavement lights, as illustrated in Annex 14, Volume I, Figure 5-26.

10.4.19 Annex 14, Volume I, specifies, as a Standard, that runway guard lights, Configuration A, shall be provided at each taxiway/runway intersection associated with a runway intended for use in:

- a) runway visual range conditions less than a value of 550 m where a stop bar is not installed; and

- b) runway visual range conditions of values between 550 m and 1 200 m where the traffic density is heavy.

10.4.20 Annex 14, Volume I, recommends that runway guard lights, Configuration A, should be provided at each taxiway/runway intersection associated with a runway intended for use in:

- a) runway visual range conditions less than a value of 550 m where a stop bar is installed; and
- b) runway visual range conditions of values between 550 m and 1 200 m where the traffic density is medium or light.

10.4.21 Annex 14, Volume I, also recommends that runway guard lights, Configuration A or Configuration B or both, should be provided at each taxiway/runway intersection where enhanced conspicuity of the taxiway/runway intersection is needed, such as on a wide-throat taxiway, except that Configuration B should not be collocated with a stop bar.

10.4.22 As the number of operations continues to increase at many airports around the world, the opportunity for runway incursions also increases. Therefore, it is further recommended to provide runway guard lights to improve the conspicuity of the location of the runway-holding position during the day and in good visibility conditions as well.

10.4.23 Runway guard lights, Configuration A, shall consist of two pairs of elevated flashing-yellow lights, and runway guard lights, Configuration B, shall consist of in-pavement flashing-yellow lights spaced at intervals of 3 m across the taxiway. The light beam shall be unidirectional in the direction of the approach to the runway holding position.

10.4.24 Where runway guard lights are intended for use during the day, it is recommended that high-intensity runway guard lights be used, in accordance with Annex 14, Volume I.

10.4.25 Where runway guard lights are installed specifically as a component of an A-SMGCS, it may be considered necessary, following a specific study, to use high-intensity runway guard lights in accordance with the recommendations of Annex 14, Volume I.

10.4.26 The installation of runway guard lights, Configuration A, has been found useful to increase the con-

spicuity of stop bars installed at runway-holding positions associated with precision approach runways.

Road-holding position lights

10.4.27 Road-holding position lights shall be used to control vehicular traffic at runway/road intersections. These lights should also be used at taxiway/road intersections.

10.4.28 Road-holding position lights should be located opposite the point at which it is desired the vehicles stop.

10.4.29 Road-holding position lights should consist of red and green signals or flashing-red lights to indicate to hold and to proceed, respectively.

10.4.30 Where a road-holding position light is used, it should be controlled as part of the SMGC system.

10.5 IMPLEMENTATION ISSUES

10.5.1 The detailed design of an SMGC system will be dependent on the operational requirements and the particular constraints of each aerodrome. The system architecture will be specific to each situation. Nevertheless, users of the system on any movement area should always have the same, standardized information presented for the same function. An example of a system architecture complying with the A-SMGCS concepts and suitable for use at a complex aerodrome having a high movement rate is shown in Figure 10-1. The way in which the visual aids are integrated into such a system is illustrated. The interrelation between the various items of equipment needed to realize the system and provide the four basic functions of guidance, routing, control and surveillance is also shown. In particular, it can be seen that the lighting aids and all other parts of the system are interdependent.

10.5.2 The selective switching of lighting is an important capability in the implementation of an A-SMGCS. The "ICAO Operational Requirements for A-SMGCS" assume the continuing use of this technique as a means of selectively indicating routes, providing dedicated guidance and assisting the control function. The selection can be done manually in response to visual observation from the control tower. In some cases, surveillance sensors can be used to assist the manual operation. In other cases a degree of automation may be introduced, as for example in the case of the reactivation of a stop bar after a fixed time interval. The control of stop bars through the use of position sensors can

be illustrated by the following example. It should be noted that the example given assumes certain ATC procedures. Different procedures require appropriate system designs to be developed.

10.5.3 Stop bars locations are provided with three aircraft position sensors as shown in Figure 10-2. Various types of position sensors, or a control signal from the A-SMGCS, can be used: position sensor 1, located across the taxiway and 70 m before the stop bar; position sensor 2, located across the taxiway and immediately after the stop bar; and position sensor 3, located across the runway and about 120 m beyond the threshold. When an aircraft is cleared to taxi for take-off, the pilot taxis following the taxiway centre line lights which remain on only up to the stop bar at the runway-holding position. When the aircraft crosses position sensor 1 (see Figure 10-2), a light appears on a special control board in the control tower. This advises

the controller that an aircraft is nearing the stop bar and that the pilot is expecting clearance to enter the runway. To permit the aircraft to cross the stop bar (see Figure 10-3), the controller not only issues a clearance through radio-telephony but also switches off the stop bar by pressing a button. This automatically illuminates that part of the taxiway centre line lighting beyond the stop bar. When the aircraft crosses position sensor 2 (see Figure 10-4), the stop bar is automatically switched on again to protect the runway. When the aircraft commences the take-off run and crosses position sensor 3 (see Figure 10-5), that portion of taxiway centre line lighting between the stop bar and position sensor 3 is automatically switched off. In the event an aircraft crosses the stop bar without authorization from the controller, position sensor 2 serves as a safety barrier (see Figure 10-6) and the system alerts the controller both visually, through a light on the control board, and by sounding an alarm.

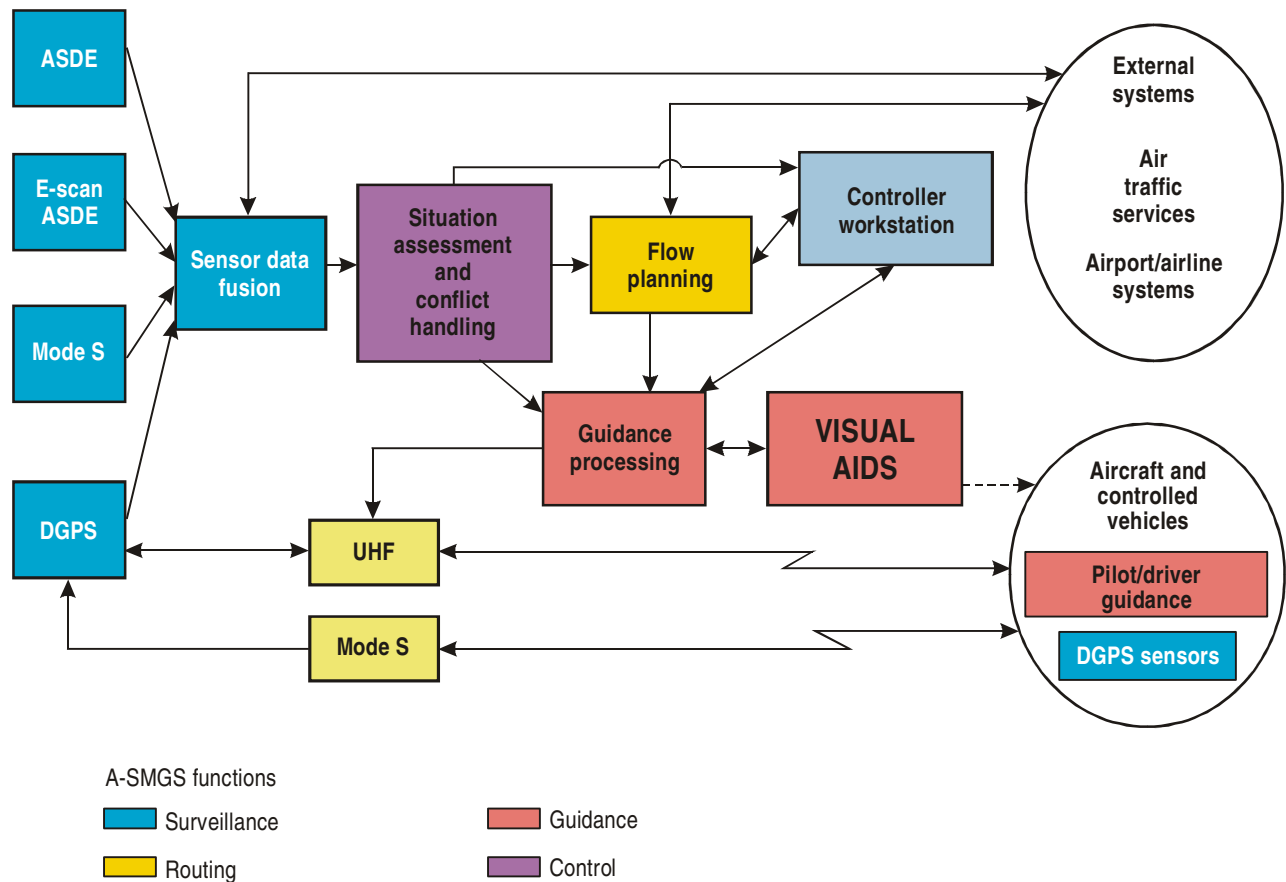

Figure 10-1. An example of A-SMGCS system architecture

10.5.4 By reference to Figure 10-1, an example may be given of the way in which selective switching of the taxiway centre line lighting can be implemented and used to facilitate aircraft movements.

10.5.5 All SMGCS implementations use some form of surveillance. In the most basic form, air traffic service personnel carry out the necessary surveillance using visual observation techniques. However, as can be seen from Figure 10-1, this function can be reliably provided by the fusion of data from a number of different types of sensors. The selection of sensors that are most appropriate to any particular implementation architecture is part of the system design process.

10.5.6 In a similar way, by using sensor-derived surveillance and other data, the selection and issue of a designated taxi route can also be implemented using computer-based systems. The output from such systems can then be used to selectively control the output of the taxiway centre line lighting. In this way, a pilot can be provided with a visual indication of the designated route together with the visual information necessary to guide the aircraft along that route.

10.5.7 Adjacent blocks of lighting ahead of the aircraft are selected simultaneously to indicate the designated route. The size of the control blocks varies. Depending on the topography of the taxiway system and the SMGC architecture, a block may be as little as one light. At the other extreme, it may be as large as the complete route from the aircraft stand to the runway-holding position.

10.5.8 The system is so designed that the length of taxiway centre line lighting available to the pilot is always such that the speed at which the aircraft can be taxied is not dependent on the extent of the route that is in view.

10.5.9 At taxiway intersections, only one route is illuminated at any time.

10.5.10 Once the surveillance system has detected that an aircraft has passed through a block, the lighting behind that aircraft is switched off in accordance with the relevant system protocol.

10.5.11 To provide guidance and control by selective switching of stop bars and taxiway centre line lights, the following design features should be incorporated in the system:

- a) a taxiway route should be terminated by a stop bar;
- b) control circuits should be so arranged that when a stop bar is illuminated, the appropriate section of taxiway centre line lights beyond it is extinguished and deactivated;
- c) the system should be so designed that a display of the taxiway layout and lighting system should be provided on a control panel capable of indicating the sections of centre line lights and stop bars which are activated;
- d) if necessary, a control should be provided, permitting air traffic controllers to override the system at their discretion and to deactivate a route which crosses an operational runway;
- e) system faults or incorrect operation of the system should be indicated by a visual monitor on the control panel.

10.5.12 It is to be anticipated that new SMGC systems will employ increased levels of automation in accordance with the "ICAO Operational Requirements for A-SMGCS".

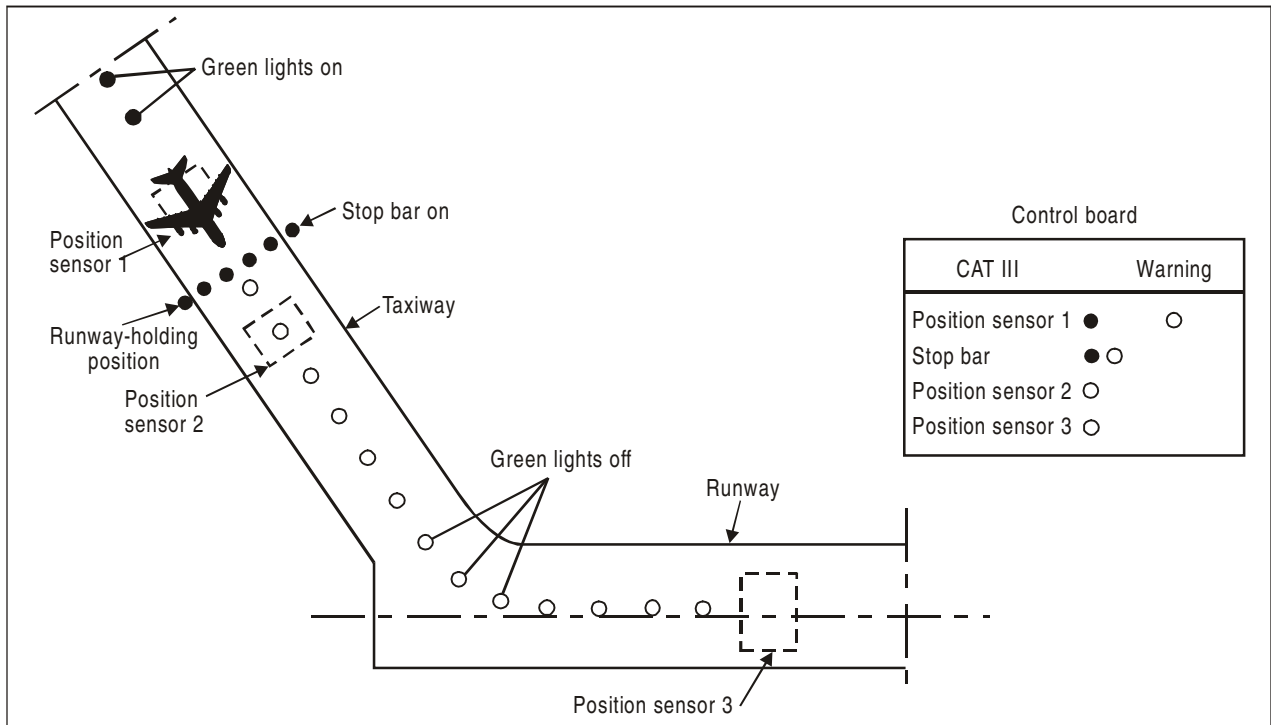

Figure 10-2. Control of stop bar through position sensors — Aircraft approaching the stop bar

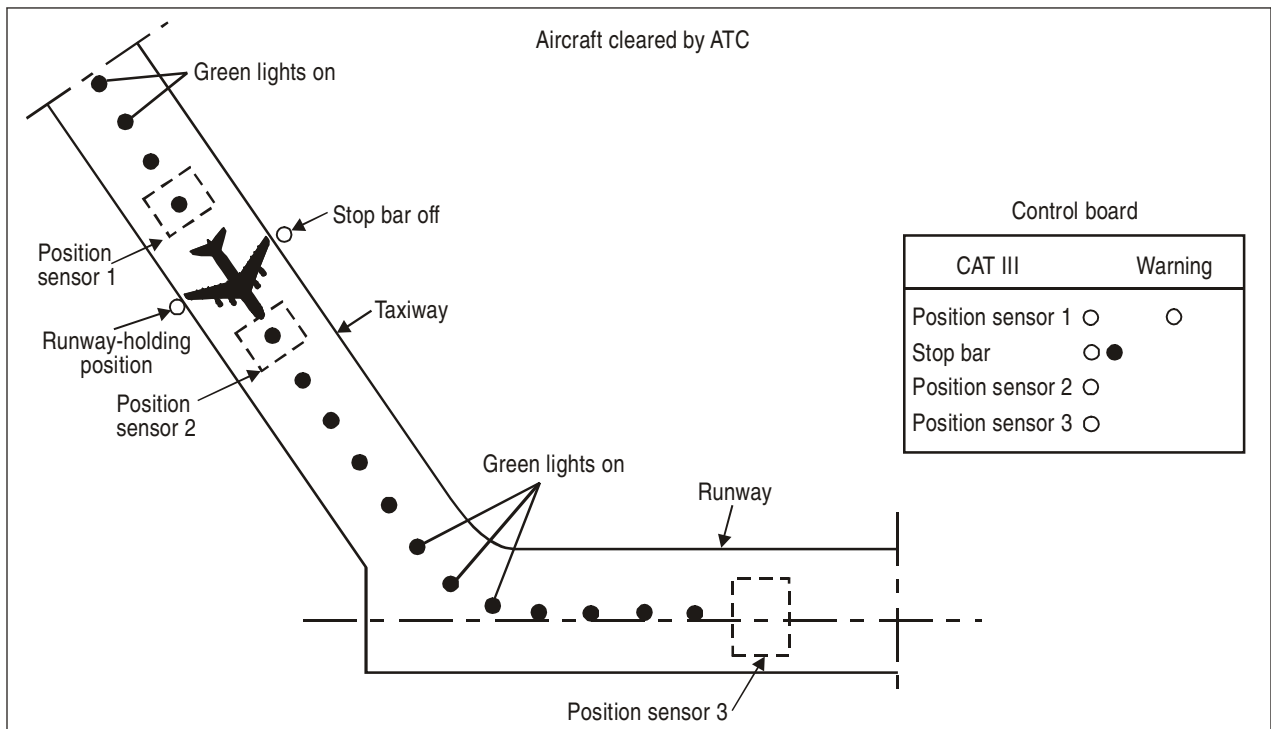

Figure 10-3. Control of stop bar through position sensors — Aircraft crossing the stop bar

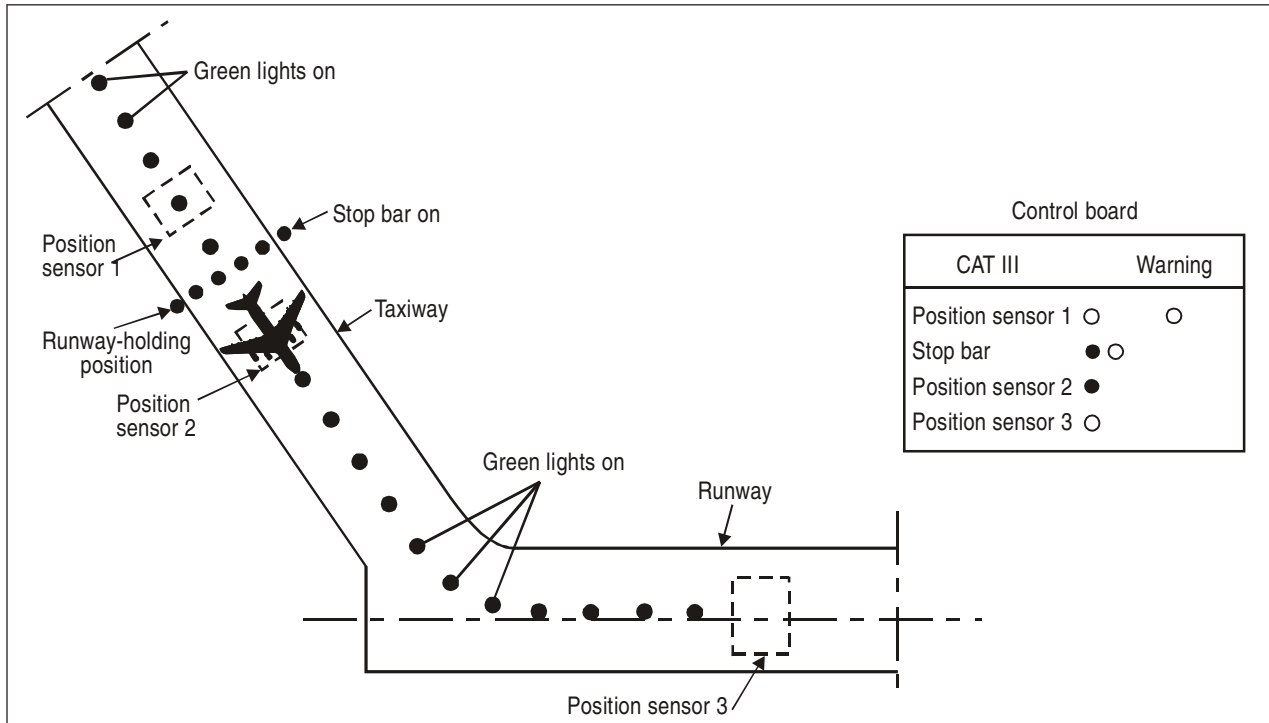

Figure 10-4. Control of stop bar through position sensors — Aircraft crossing position sensor 2

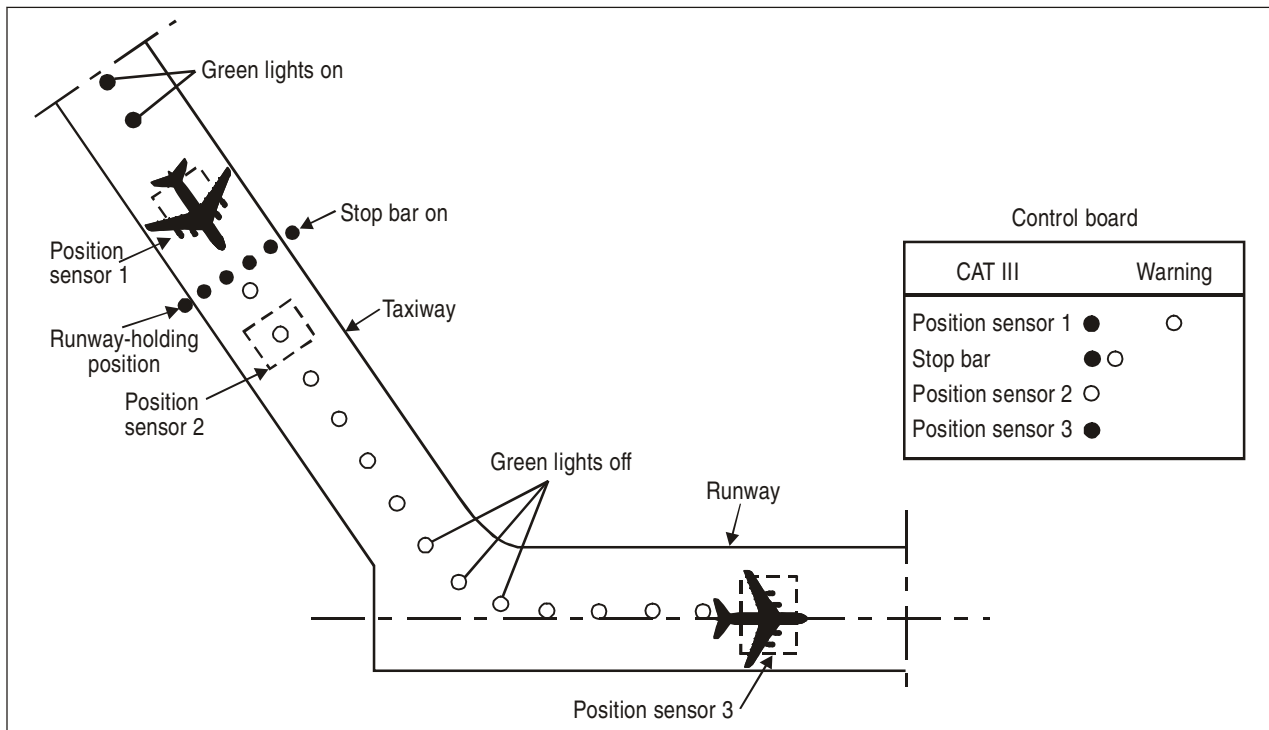

Figure 10-5. Control of stop bar through position sensors — Aircraft crossing position sensor 3 and another aircraft approaching the stop bar

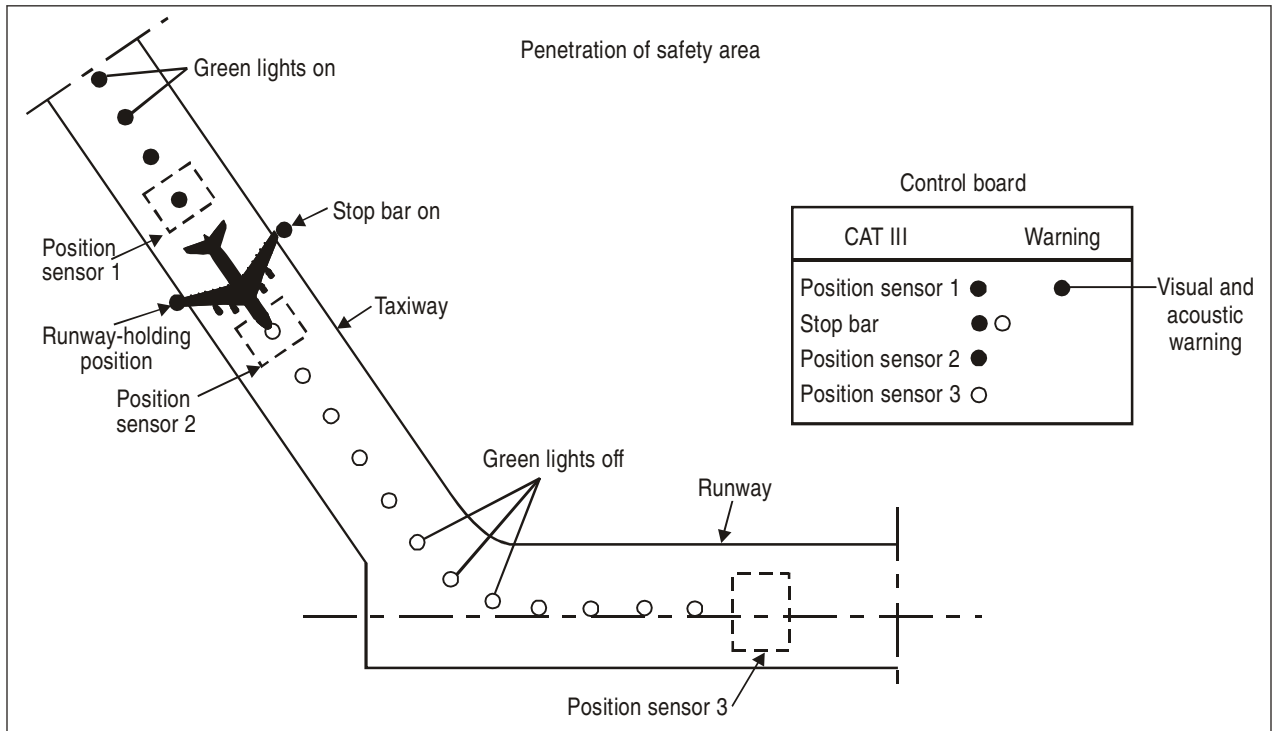

Figure 10-6. Control of stop bar through position sensors — Aircraft crossing the stop bar without clearance

Chapter 11

Signs

11.1 GENERAL

11.1.1 The achievement of safe and efficient aircraft taxiing and ground movement at aerodromes requires the provision of a system of signs for the use of pilots and vehicle drivers on the movement area.

11.1.2 Pilots and vehicle drivers use the signs to identify their position on the movement area. By relating this data to ground map information available in the cockpit or in the vehicle, they can ensure that they are on their assigned route at all times. They can also, as required, report their position to ATC.

11.1.3 At some locations, the signs convey mandatory instructions related to that particular position, thus contributing to the safety of operations.

11.1.4 Signs at intersections expedite movements by indicating the layout of the taxiways at that position. Provided that the sign is seen in sufficient time, pilots and vehicle drivers can then easily identify the exit from the intersection that corresponds to their assigned route.

11.1.5 All signs are classified as either mandatory or information signs.

11.1.6 A mandatory sign shall be provided to identify a location beyond which a vehicle or taxiing aircraft shall not proceed unless authorized by the air traffic management service.

11.1.7 An information sign shall be provided where there is an operational need to indicate, by a sign, a specific location, or routing (direction or destination) information, or to provide other information relevant to the safe and efficient movement of aircraft and vehicles.

11.2 DESIGN

11.2.1 The system of signs specified in Annex 14, Volume I, Chapter 5, 5.4 and Appendix 4, meets a number of design criteria.

11.2.2 All signs conform to a colour code that clearly indicates the function of each sign. Mandatory signs use red and white, and information signs use yellow and black. The choice of colours was influenced by colour conventions in other modes of transport where colours have specific and well-understood meanings. It was also influenced by the need to use pairs of colours which, in combination, provide signs that are legible in the widest possible range of conditions. Contrast ratios between the elements of the sign are a major factor in determining the legibility of a sign.

11.2.3 There are four basic attributes related to the design of signs:

- a) conspicuity;
- b) legibility;
- c) comprehensibility; and
- d) credibility.

11.2.4 Each of these attributes is important. To meet the operational requirements, all signs must be readily seen in the complex aerodrome environment, and the inscription on the sign face must be easy to read. The message being conveyed by the sign must be readily understood by pilots and vehicle drivers, and it must also provide information that is clearly correct.

11.2.5 The overall size, colour and luminance of a sign determine the level of conspicuity. The size, font and layout of the inscriptions together with the luminance contrast between the inscription and the sign face determine the legibility of the signs.

11.2.6 Full compliance with the criteria in Annex 14, Volume I, Appendix 4, concerning the sign face size is necessary to maximize the conspicuity of the signs and to ensure that the sign characters are legible. The design criteria require a sign face that is always twice the height of the inscription. The width is determined by the overall

length of the inscription to which must be added a border of at least 0.5 times the inscription height at either end of the sign. For signs containing only one designator, the lateral border width is required to be equal to the inscription height. This ensures that a sign face of suitable size is provided in all situations. The requirements of Annex 14, Volume I, Appendix 4, paragraph 11, should be met for mandatory signs.

11.2.7 The font size chosen depends on the maximum range at which the inscription is required to be legible. For an aircraft taxi speed of 30 kt and assuming a reading time of 10 seconds, plus a small allowance for an initial search time to locate the sign, the required font height is at least 30 cm. A font size of 40 cm is applied to enhance the sign performance especially in locations where the level of safety is of particular importance. The font to be used for signs is specified in detail in Annex 14, Volume I, Appendix 4.

11.2.8 The luminance of the signs is specified to maximize the useful range of the signs in reduced visibility conditions.

11.2.9 The position of signs and the location of the various elements of the sign message strongly influence the comprehensibility of the sign system. The layout of the signs, particularly for applications at complex intersections where several sign elements are collocated, is specifically designed to ensure the speedy and accurate assimilation of the information displayed. The inscriptions specified are chosen to ensure that the information is easily understood by all users. An example of a complex sign layout is given in Figure 11-1.

11.2.10 For operations that take place in low visibility or at night, the illumination of the sign face is an important design parameter. The sign luminances that are specified in Annex 14, Volume I, Appendix 4, have been found to meet the operational criteria in these circumstances. Two sets of luminances are given. The higher luminances are only essential during operations in runway visual range conditions less than a value of 800 m. At night in good visibility conditions, the luminance of signs can be reduced as indicated provided that sign conspicuity and legibility criteria are maintained.

11.2.11 To maximize legibility, it is important that the equipment is designed to have a uniform luminance over the complete sign face. Similarly, the specified luminance ratios between the colours of the sign should always be complied with.

11.3 VARIABLE MESSAGE SIGNS

11.3.1 Conventional signs displaying a fixed message show the same information at all times irrespective of the operational circumstances. This can result in situations that are at least illogical and which could cause operational problems. For example, a pilot taxiing for departure in VMC will be expected to pass a mandatory Category I, II, III or joint II/III holding position sign without obtaining clearance from ATC. This procedure is followed on the basis that the sign is not applicable at the time when the manoeuvre takes place. The potential for any misunderstanding could be removed if the sign information were only visible when the information being displayed is applicable. Selective use of taxiways as part of a full surface movement guidance and control system or as a means of maintaining separations between very large aircraft on close parallel taxiways are other examples of the need for more flexibility in the way in which sign information is displayed. It is recommended in Annex 14, Volume I, 5.4.1.2, that variable message signs be provided to meet the operational needs described above.

11.3.2 Therefore, a variable message sign should be provided when:

- a) the instruction or information displayed on the sign is relevant only during a certain period of time; and/or
- b) there is a need for variable pre-determined information to be displayed on the sign to meet the requirements of surface movement guidance and control systems.

11.3.3 Variable message signs can be designed to provide high brightness without glare and facilitate the selective display of information. Technologies that could be used include fibre optic or light emitting diodes. The use of such technologies to create the sign message enhances range performance compared with that obtained by using transilluminated signs. The luminance of a fibre optic or light emitting diode light point can be approximately 10 000 cd/m² compared with the value of 300 cd/m², which is the highest value normally used for transilluminated signs.

11.3.4 The following guidelines should be applied to the design of any variable message sign to be used on an aerodrome movement area:

- a) the sign should have a blank face when not in use. A pilot must not see an image or “ghost” of the message;

- b) the sign should not present a message that could lead to an unsafe action by a pilot in the event of failure of the sign;
- c) the sign should have a short response time, i.e. the time required for the message to change should be not greater than five seconds;
- d) different luminance levels will be required for day/night operations and in good/poor visibilities;
- e) care should be taken to ensure that the field of view of the sign is sufficient over the full range of viewing angles that are required for taxiway signs; and
- f) the sign should only include colour and inscription elements that conform to the basic conventions that are to be followed in the design of mandatory and information signs.

11.4 MANDATORY INSTRUCTION SIGNS

11.4.1 A mandatory instruction sign identifies a location on the movement area that a pilot or vehicle driver should not pass without specific authorization by ATC. Mandatory instruction signs are therefore an important element of the safety provisions on movement areas.



Figure 11-1. Example of a complex sign layout

11.4.2 Mandatory instruction signs shall always be located on each side of the taxiway or the runway. This enables pilots to have an uninterrupted view of the signs when they are located close to an intersection that can be approached from more than one direction.

11.4.3 Mandatory instruction signs include runway designation signs, Category I, II or III holding position signs, runway-holding position signs, road-holding position signs and NO ENTRY signs. Examples of such signs are shown in Figure 11-2.

11.4.4 A mandatory instruction sign shall always be provided at a taxiway/runway intersection or a runway/

runway intersection on each side of the runway-holding position. Thus Annex 14, Volume I, specifies that:

- a) a pattern “A” runway-holding position marking shall be supplemented at a taxiway/runway intersection or a runway/runway intersection with a runway designation sign; and
- b) a pattern “B” runway-holding position marking shall be supplemented with a Category I, II or III holding position sign.

11.4.5 As a consequence, where a single runway-holding position is provided at an intersection of a taxiway and a precision approach Category I, II or III runway,

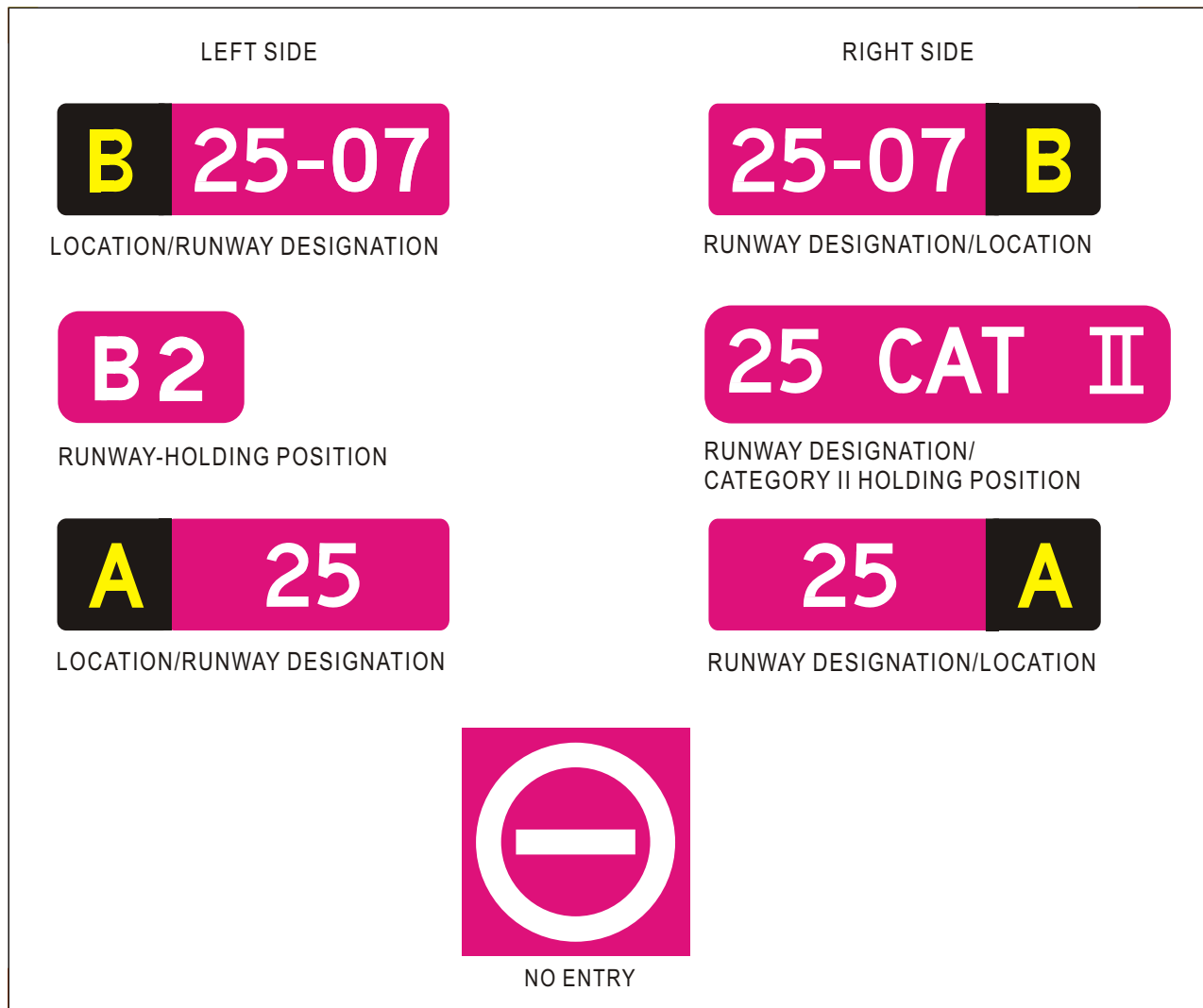

Figure 11-2. Mandatory instruction signs

the runway-holding position marking shall always be supplemented with a runway designation sign. Where two or three runway-holding positions are provided at such an intersection, the runway-holding position marking closest to the runway shall be supplemented with a runway designation sign, and the markings farthest from the runway shall be supplemented with a Category I, II or III holding position sign, as appropriate.

11.4.6 Examples of sign positions at taxiway/runway intersections are shown in Figure 11-3.

Note.— A runway-holding position is defined as a designated position intended to protect a runway, an obstacle limitation surface, or an ILS/MLS critical/sensitive area at which taxiing aircraft and vehicles shall stop and hold, unless otherwise authorized by the aerodrome control tower.

11.4.7 A runway-holding position shall be established on a taxiway if the location or alignment of the taxiway is such that a taxiing aircraft or vehicle can infringe an obstacle limitation surface or interfere with the operations of radio navigation aids. At such runway-holding positions, Annex 14, Volume I, specifies that a pattern “A” runway-holding position marking shall be supplemented with a runway-holding position sign (the “B2” sign in Figure 11-2) on each side of the runway-holding position.

11.4.8 Location signs should be associated with a runway designation sign wherever it is important to ensure that there can be no possible ambiguity in the authorization process. Without exact knowledge of location, it is possible for pilots taxiing at an aerodrome that has multiple runway/taxiway intersections to misinterpret an authorization issued for another aircraft as being applicable to their movement and mistakenly manoeuvre onto the runway. Thus, Annex 14, Volume I, recommends that a runway designation sign at a taxiway/runway intersection should be supplemented with a location sign in the outboard (farthest from the taxiway) position, as appropriate.

11.4.9 A NO ENTRY sign shall always be provided when entry into an area is prohibited.

11.4.10 For road-holding positions where a road enters a runway, the provisions of Annex 14, Volume I, 5.4.7, should be applied. An example of a road-holding position sign is shown in Figure 11-4. Since these signs are to be used by aerodrome personnel, it is important that the inscriptions on the sign face are in a language that is comprehensible to all road users at that location.

11.5 INFORMATION SIGNS

11.5.1 Information signs enable pilots and vehicle drivers to continuously monitor their position on the movement area. These signs are intended to be an aid to the safe and efficient navigation of all aircraft and vehicles.

11.5.2 Information signs shall include: direction signs, location signs, destination signs, runway exit signs, runway vacated signs and intersection take-off signs.

11.5.3 Examples of information signs are shown in Figure 11-5. Sign systems displaying a combination of location and direction information are the most commonly used. In Figure 11-5, four examples are given of this type of application. The two simplest examples are alternative ways of indicating prior to a position, where only two taxiways intersect, the designation of the taxiway on which the aircraft or vehicle is currently located and the designation of the crossing taxiway. From this information and reference to an aerodrome map, pilots and vehicle drivers can uniquely identify their exact location and the direction that they must take at the junction to remain on their assigned route.

11.5.4 It is only for this simplest of taxiway layouts that the option of placing the location information at the end of the sign array is permitted. At all other, more complex intersections the position of the location sign and the associated direction signs must correspond to the convention that the sign layout should directly reflect the intersection geometry. All taxiways requiring a turn to the left must be indicated by a sign inscription placed to the left of the location sign, and all turns to the right must be indicated by a sign inscription placed to the right of the location sign. In addition, the order in which the crossing taxiway information is displaced from the location sign is determined by the magnitude of the turn required to enter that designated taxiway. Thus taxiways that require the smallest change of direction are placed closest to the location sign and those requiring the greatest change of direction are placed furthest from the location sign.

11.5.5 During the development of the signage system, it was demonstrated that by using the sign layout adopted in the standard described above, pilots needed less time to read and interpret the information than with any other layout. Furthermore, they did not make the mistakes in interpreting the taxiway configuration that occurred when testing other sign layouts.

11.5.6 The clear differentiation between location signs and all other information signs that is secured by the

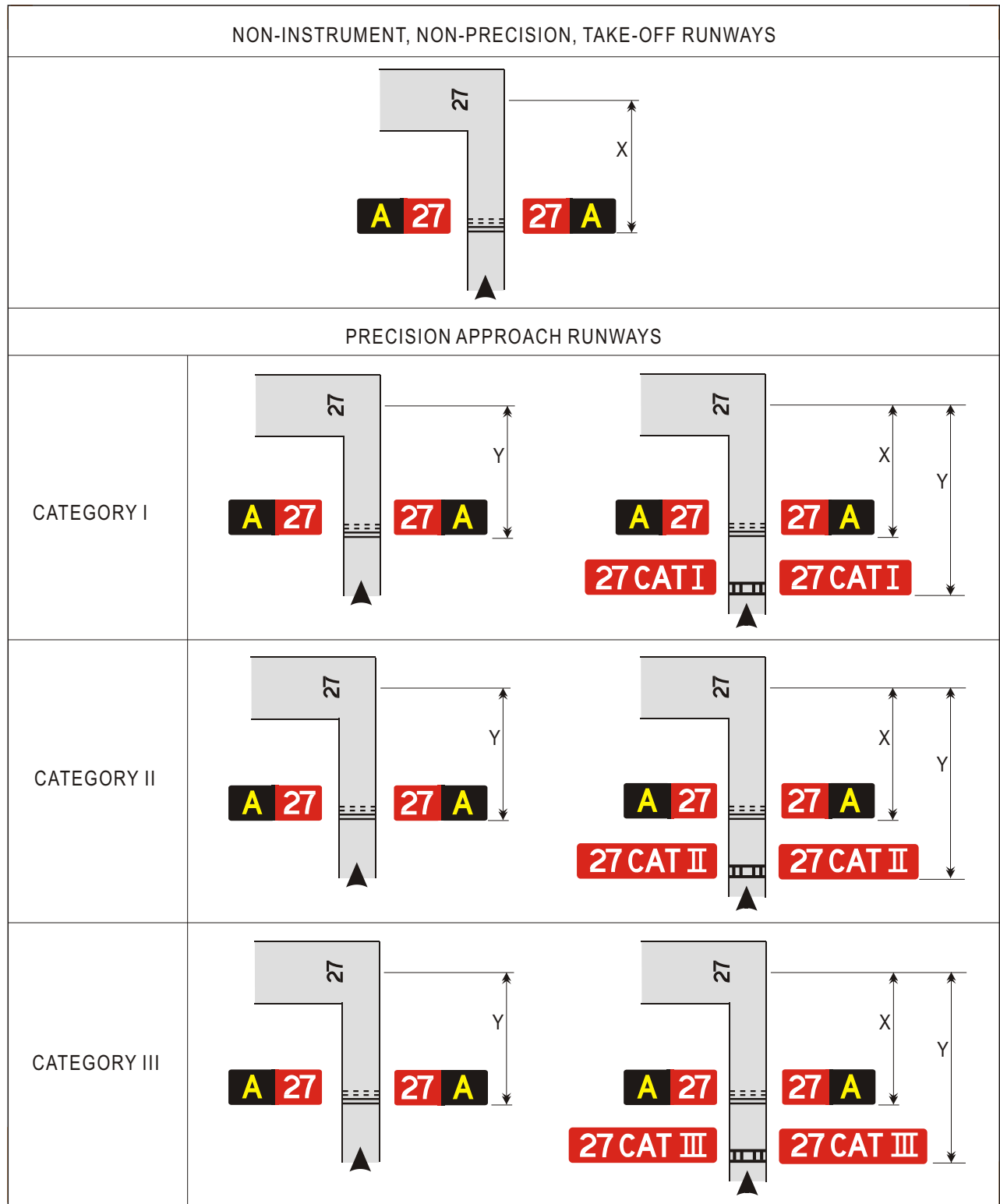

Note.— Distance *X* is established in accordance with Annex 14, Volume 1, Chapter 3, Table 3-2. Distance *Y* is established at the edge of the ILS/MLS critical/sensitive area.

Figure 11-3. Examples of sign positions at taxiway/runway intersections

reversal of the yellow/black colour combination is also an important element of the system. Location signs are an essential element of the signage at taxiway intersections, but they also have an important function wherever it is necessary to uniquely identify a position on the movement area. For example, a suitably sited location sign can expedite position reporting when an aircraft is manoeuvring off the runway.

11.5.7 Where information is displayed to a pilot on the runway, location information is omitted from the sign system. Only direction information is displayed in this situation.

11.5.8 Where it is necessary to provide intermediate holding positions on a taxiway at locations other than a runway/taxiway intersection, the location signs should consist of the taxiway designator supplemented by a number.

11.5.9 An example of the way in which designating letters are assigned to a taxiway system is shown in Figure 11-6. In this figure, taxiways A, C and D are typical taxiways that may require the designation of intermediate holding positions to facilitate ground movement operations.

11.6 SIGN LOCATION

11.6.1 Signs have to be readily seen by pilots and vehicle drivers as they manoeuvre their aircraft/vehicles on the movement area. This is best achieved when the signs can be read when pilots are following the guidance that is derived from their view of the taxiway ahead of the aircraft. Signs should therefore be placed as close to the edge of the pavement as is practicable.

11.6.2 When choosing the location of a sign, the provisions of Annex 14, Volume I, 5.4, shall be followed. The taxiway environment is such that the guidance on siting must be followed if damage due to impact with engine pods or propellers or as a result of jet blast effects is to be avoided.

11.7 SIGN EVALUATION

General

11.7.1 The physical characteristics of taxiway signs are determined by the operational requirements reflected in the provisions of Annex 14, Volume I, Appendix 4. The colours used in any sign should conform to the specifications given in Annex 14, Volume I, Appendix 1, Figures 1.2 to 1.4.

11.7.2 To achieve the specified luminance performance for lighted signs, it is generally found that transilluminated signs best meet the requirements. The uniformity of the illumination influences the legibility of a sign. Unevenly lit signs are difficult to read and are therefore not acceptable in a taxiway signage system.

11.7.3 Before a sign is installed, it should be demonstrated that the requirements of Annex 14, Volume I, Appendix 4, are met by the sign design. It is important that both luminance and colour specifications are fully complied with. To demonstrate this compliance, it is necessary to carry out tests on a sign that fully represents the size, colour, inscription layout and lighting system that will be used in service.

11.7.4 The dimensions and location of the reference grid points used for testing sign luminance should always be



Figure 11-4. Road-holding position sign

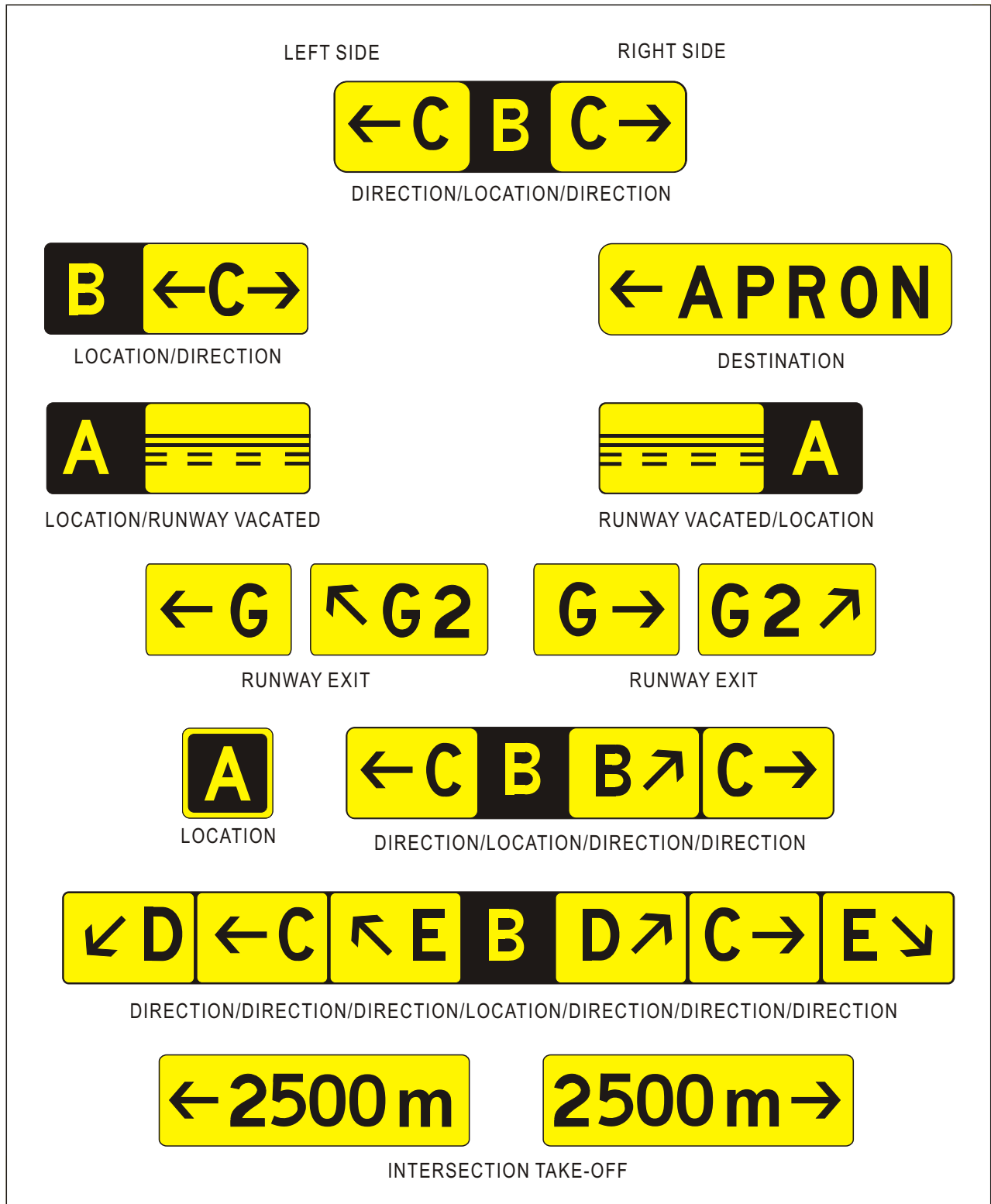

Figure 11-5. Information signs

strictly in accordance with the specifications of Annex 14, Volume I, Appendix 4, Figure 4.1. Relaxation of the test specifications in terms of grid size or grid point location is not an acceptable means of making a specific sign compliant with the requirements.

11.7.5 When a sign is tested for compliance, all parameters should be evaluated including font size, inscription location, the size of the borders around the inscription and the overall dimensions of the sign face.

11.7.6 Taxi guidance signs shall be frangible but shall also be able to withstand significant wind velocities. For design purposes, a wind speed of at least 60 m/s can be used. In some places, such as any location that is close to

the point on a runway where large aircraft are rotated during the take-off run, higher design wind speed values may be appropriate. However, at some locations in the movement area, signs may be exposed to wind velocities of up to 90 m/s caused by jet blast.

11.7.7 Structural members supporting a sign face should not constitute part of the sign face dimensions. When the structure of the design overlaps the sign face, the dimensions of the face should be adjusted accordingly to ensure that the correct area of sign face is provided.

11.7.8 The rear of the sign should be marked in a single conspicuous colour except where signs are mounted back-to-back.

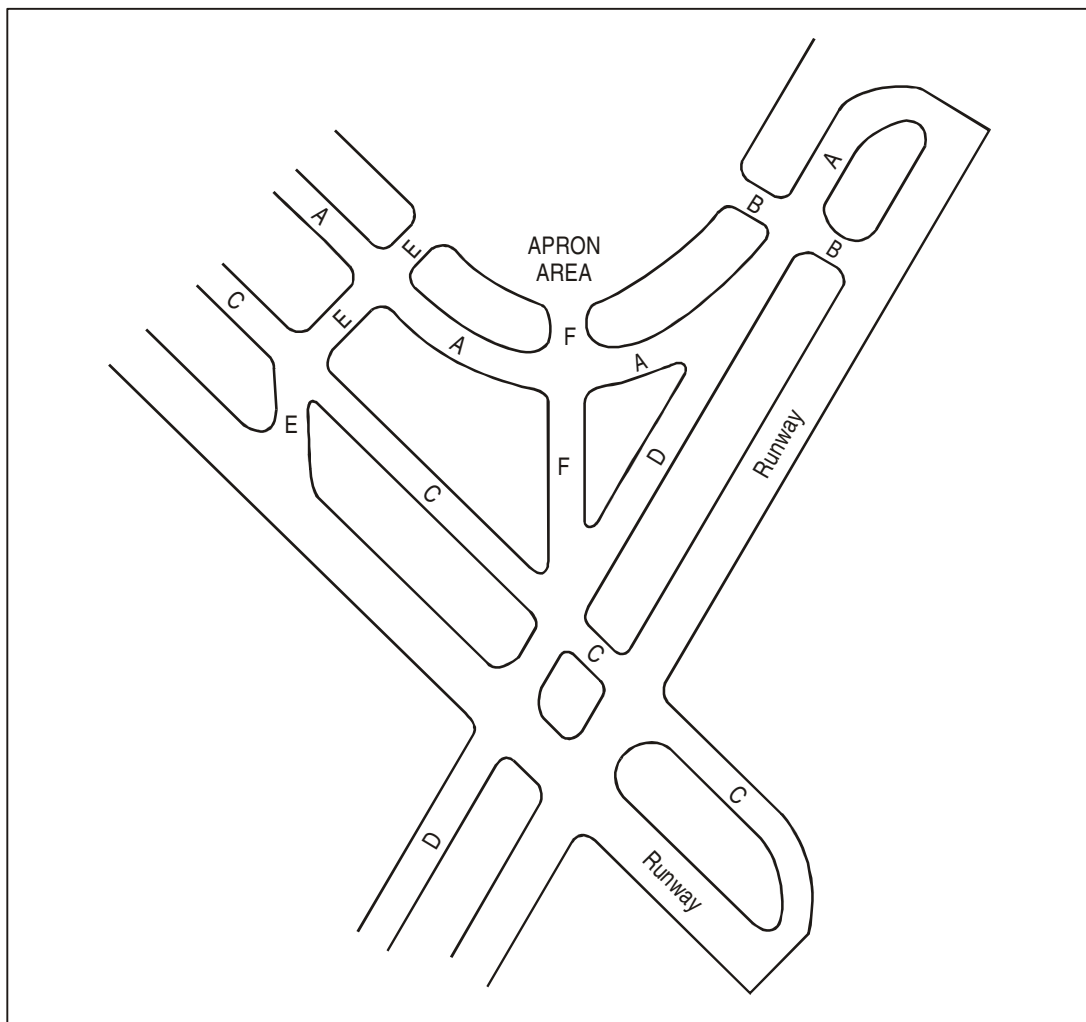

Figure 11-6. Assignment of letters to taxiways

11.7.9 Examples of typical signs that comply with these specifications are shown in Figure 11-7.

Evaluation procedures

11.7.10 To evaluate the physical characteristics of a sign, the following procedures should be applied:

- a) assess the category of operation for which the sign is to be used;
- b) measure the height and width of the sign face, excluding the holder frame where applicable;
- c) measure the height of all characters;
- d) measure the stroke width of each character and ensure that the stroke width is consistent around the characters, particularly those that contain curved components;
- e) measure the width of each character;
- f) measure the space around the characters, top, bottom, right and left;
- g) measure the border width where applicable;
- h) measure the space between words where applicable;
- i) where two types of signs are in one unit (e.g. taxiway mandatory and information signs), measure the separation between the signs; and
- j) compare the measured dimensions and spacings with the recommendations given in Annex 14, Volume I, Appendix 4.

11.7.11 To evaluate the photometric performance of a sign, the following procedures should be applied:

- a) evaluate the photometric performance of the sign in a darkened environment;
- b) mark out the grid on the sign face as shown in Annex 14, Volume I, Appendix 4, Figure 4.1 (exclude any framework). Ensure that the rows/columns of grid points are correctly aligned parallel to both the top and left edge of the sign face;
- c) at an appropriate range from the sign, measure the luminance and colour coordinates at each applicable grid point ensuring that the area used for each indi-

vidual measurement does not exceed that prescribed by a circle of 3 cm in diameter centred on the grid point. For externally lit signs, ensure that the measurement is taken from behind the light source;

- d) calculate the average luminance level for each colour and compare the values with the minimum values recommended in Annex 14, Volume I, Appendix 4;
- e) ensure that uniformity of luminance has been achieved by calculating the ratio between the maximum and minimum luminance values for each colour and comparing it with the maximum recommended ratio in Annex 14, Volume I, Appendix 4;
- f) for a mandatory (red and white) sign, confirm that the maximum and minimum ratios between the average red luminance and the average white luminance are within the recommended range specified in Annex 14, Volume I, Appendix 4;
- g) assess the ratios of adjacent luminance levels in the vertical and horizontal planes and compare them with the recommended maximum ratio given in Annex 14, Volume I, Appendix 4 (assess the ratio between adjacent points of the same colour only); and
- h) calculate the average of the colour coordinates for each colour and confirm that the values are within the boundaries recommended in Annex 14, Volume I, Appendix 1.

Note.— Signs of different lengths may have different photometric performances.

Determining the width of a sign face

11.7.12 The examples in Tables 11-1 and 11-2 provide guidance on how to determine the width of a sign face.

Note.— The width of the space between character groups or character groups and symbols should be equal to the average height of the letter used:

<i>Letter height</i> (mm)	<i>Average letter width</i> (mm)
400	280
300	210
200	140



Figure 11-7. Examples of typical sign designs

**Table 11-1. Inscription: 27 CAT III
(letter height 400 mm)**

Item	Width (mm)
½ H	200
2	274
character space	76
7	274
character group space	280
C	274
character space	50
A	340
character space	26
T	248
character group space	280
III	440
½ H	200
Total width	2 962

**Table 11-2. Inscription: APRON →
(letter height 300 mm)**

Item	Width (mm)
½ H	150
A	255
character space	57
P	205
character space	71
R	205
character space	57
O	214
character space	71
N	205
character group space	210
→	300
½ H	150
Total width	2 150

Chapter 12

Visual Parking and Docking Guidance Systems

12.1 INTRODUCTION

Precise positioning of aircraft

In many cases aircraft are required to park in a prescribed position to ensure the required clearance from other aircraft. Precise positioning of aircraft is particularly required when special passenger loading facilities connect the terminal building to the aircraft. Also, where fixed servicing installations are provided for refuelling, electric ground power, water, ground communication lines, compressed air, and so on, accurate positioning of aircraft is of importance for their safe and efficient operation. A system based on markings and inset lights and used for the positioning of aircraft at terminals not equipped with passenger boarding bridges is known as an apron parking guidance system. At terminals equipped with passenger boarding bridges, a more sophisticated system is needed for the docking of aircraft. Such a system is known as a visual docking guidance system. The operational requirements of the docking guidance system are included in Appendix 1, and those of the parking guidance system in Appendix 2.

12.2 AIRCRAFT STAND MANOEUVRING GUIDANCE LIGHTS

In 2.3.1, it was mentioned that for manoeuvring aircraft under poor visibility conditions, closely spaced lights similar to the taxiway centre line lights are needed on aircraft stands in addition to markings. These lights, which are called aircraft stand manoeuvring guidance lights, should be omnidirectional so that they are visible to a pilot approaching along a taxiway at a right angle to the stand centre line. Low-intensity taxiway lights emitting yellow light are normally used. An intensity of approximately 60 cd of yellow light is needed to support operations down to a visibility equivalent to an RVR of 50 m. The surface

temperature of the light fittings must be sufficiently low so as not to affect aircraft tires coming in contact with them. The lights are normally spaced at 15 m intervals.

12.3 VISUAL DOCKING GUIDANCE SYSTEM

12.3.1 While aircraft stand manoeuvring guidance lights will provide adequate guidance to initiate the turn on and take up a position on the centre line, they are not necessarily sufficient to achieve the azimuth accuracy necessary for nose-in stands equipped with passenger boarding bridges. Furthermore, to stop the aircraft at the correct position, stopping guidance is essential. Visual docking guidance systems are therefore installed at terminals equipped with passenger boarding bridges.

12.3.2 The Annex 14, Volume I specifications for the visual docking guidance system conform to the operational requirements in Appendix 1. Care should be exercised when choosing such a system. The basic features of a few types of visual docking guidance systems which have been found to satisfy most, if not all, of the operational requirements and specifications are outlined in the following paragraphs.

Systems using graphical display based on aircraft position sensors

12.3.3 A visual docking guidance system which uses a graphical display and laser-based sensors to provide azimuth guidance, distance-to-go and stopping position information is detailed in Figure 12-1. This system consists of a real-time LED (light emitting diode) display unit, a control unit and a laser scanning unit all housed in the same cabinet. The cabinet is attached to the terminal building or other support close to the extension of the aircraft stand

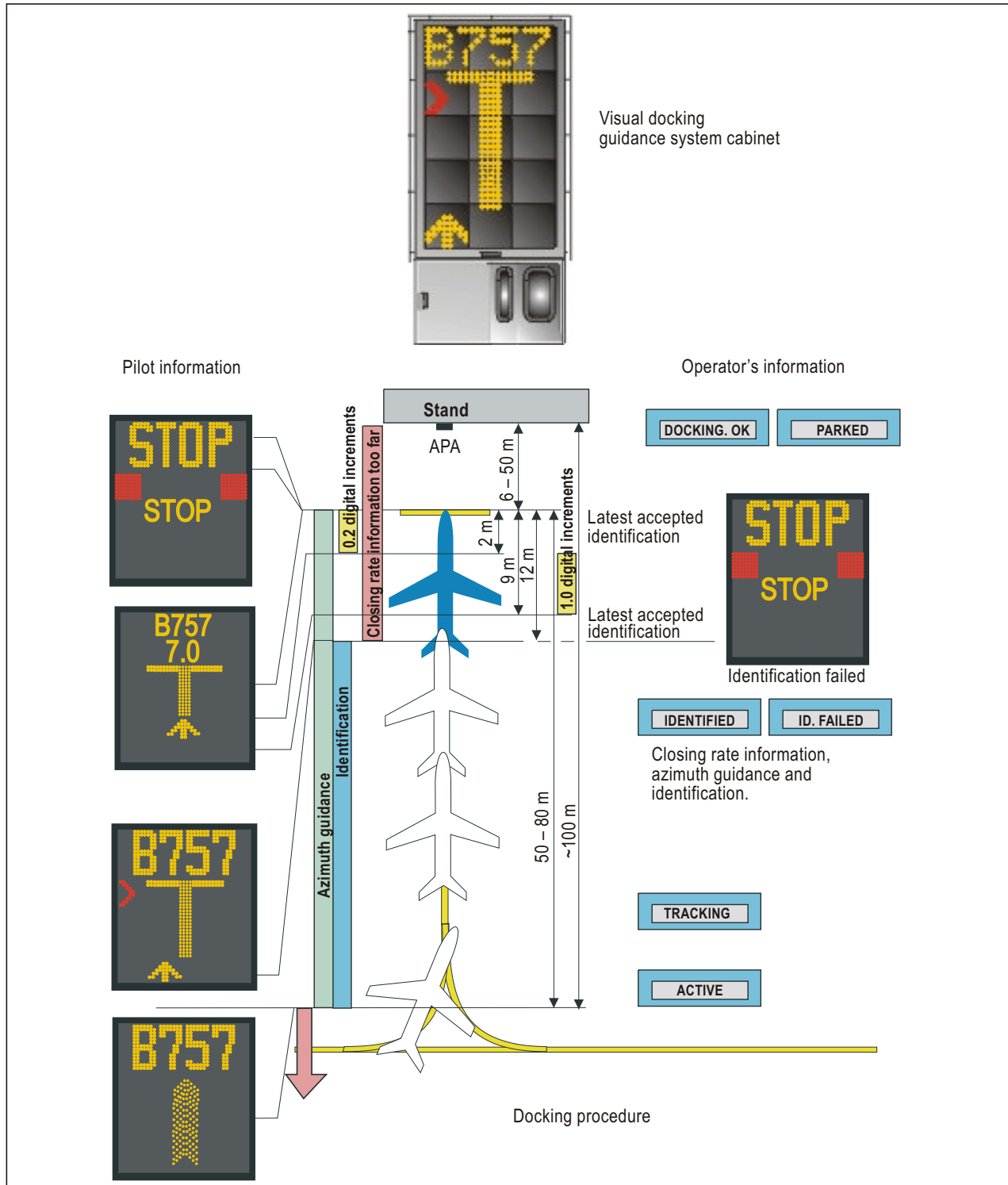

Figure 12-1. A visual docking guidance system using a graphical display and laser-based sensors to provide azimuth guidance, distance-to-go and stopping position information

centre line. The system also includes an operator control panel comprising an alphanumeric display screen and an emergency stop push-button. The operator control panel is mounted at apron level.

12.3.4 The display unit incorporates three different indicators for alphanumeric, azimuth and distance-to-go information, all of which are clearly visible from both pilot positions in the aircraft. The display comprises an array of LED indicators, yellow and red indicator boards, each housing a processor board connected in series to the control unit via a ribbon cable. A serial communication protocol is used for the communication between the control unit and the LED-modules. The upper two rows are used for alphanumeric information, the third row for azimuth information and the central vertical bar for distance-to-go information.

12.3.5 The alphanumeric display, shown in yellow, will present information such as abbreviations for aircraft type, airport code and flight number. Special text information for guidance is also displayed to the pilot in the docking phase. The azimuth guidance indicator, displayed as a red arrow, gives information to the pilot on how to direct the course of the aircraft. A yellow vertical arrow shows the actual position of the aircraft in relation to the aircraft stand centre line. The system supports multiple convergent centre lines as well as curved centre lines. The distance-to-go indicator, shown in yellow, comprises 32 horizontal elements which will display as a vertical bar that symbolizes the centre line. Each horizontal element represents a distance of 0.5 m.

12.3.6 By using anti-reflective material in the display window and dark coloured LED-boards, together with automatic adjustment of the LED light intensity, the displayed information is legible in all light conditions.

12.3.7 The laser scanning unit is housed in the lower part of the display unit cabinet. The unit, based on three-dimensional technology, comprises a laser range finder and scanning mirrors. The unit also incorporates a fixed mirror for use during self-testing of the system.

12.3.8 Three-dimensional profiles for selected aircraft using specific parameters for the geometry of the aircraft are programmed into the visual docking guidance system. During the docking procedure, the laser equipment measures the corresponding parameters of the approaching aircraft.

12.3.9 The docking procedure, as illustrated in Figure 12-1, can be activated by:

- a) the operator of the visual docking guidance system who will select the aircraft type from the operator control panel;
- b) remote selection of aircraft type by a gate management system, which will have to be confirmed by the operator of the visual docking guidance system at the operator control panel; or
- c) automatic selection of aircraft type by a gate management system based on information from the flight information display system (FIDS).

12.3.10 Before any docking procedure can be activated, a self-test will be performed by the system. The correct position of a permanent test object located in a known position will be checked. A failed test will result in an error message on the LED display. If the self-test is successful, the aircraft type will be shown on the LED display unit as well as on the operator control panel. Floating arrows on the azimuth and distance-to-go will indicate that the system is ready for operation. The laser scanning unit is now activated, and the operator control panel will indicate the aircraft type and the status of the laser scanning unit as “ACTIVE”.

12.3.11 When the aircraft is detected by the laser rangefinder, usually more than 50 m before the stop position, the distance-to-go LED display will be activated. The azimuth display, the yellow arrow, will indicate the lateral position of the aircraft with respect to the aircraft stand centre line, and a red flashing arrow will indicate the direction of any required course adjustment. The operator control panel will show “TRACKING”.

12.3.12 During the approach of the aircraft towards the stop position, the aircraft type will be verified by the system by comparing captured data to those programmed for the selected aircraft. If aircraft type verification is not established within 12 m from the stop position, the LED display unit will show “STOP/ID FAIL”. If the captured data will verify the aircraft type, the operator control panel will show “IDENTIFIED”.

12.3.13 When the aircraft is within a specified distance (12 m or 16 m) from the stop position, the height of the distance-to-go indicator will gradually decrease (the horizontal elements of the yellow bar will be switched off one by one) as the aircraft approaches the stop position. When the aircraft has reached the stop position, the alphanumeric display will indicate “STOP” together with two red stop symbols. When no movement of the aircraft can be detected after a preset time period, the alphanumeric display will change from “STOP” to “OK” or “TOO FAR”,

as the case may be. This will also be indicated on the operator control panel. After an additional preset time period, the status on the operator control panel will change to "PARKED".

12.3.14 Another visual docking guidance system that uses a graphical display of the pattern of interference fringes formed by optical gratings (Moiré technique) to provide azimuth guidance and a laser radar to provide distance-to-go and stopping position information is detailed in Figure 12-2. This system consists of a display unit, a control unit and a laser radar unit all housed in an aluminium enclosure. The enclosure is attached to the terminal building or other support close to the extension of the aircraft stand centre line. The system also includes an operator control panel comprising a display terminal and an emergency stop button. The operator control panel is normally located in the passenger boarding bridge or at ground level.

12.3.15 The display unit incorporates three different indicators for alphanumeric, azimuth and distance-to-go information. The alphanumeric and distance-to-go indicator will provide information to both the pilot and the co-pilot. The azimuth indicator will provide guidance only to the pilot. To provide azimuth information to the co-pilot, an additional co-pilot azimuth guidance unit will be required.

12.3.16 The alphanumeric indicator will display horizontal text information, such as aircraft type, "STOP", failure codes, etc. It consists of four alphanumeric display panels each of which is a 7 by 5 yellow fluorescent dot matrix. Illumination is provided by a fluorescent tube.

12.3.17 The distance-to-go indicator provides information based on a laser range measurement technique. The laser measures the distance to the aircraft, and the display presents the measured distance relative to the parking position in analogue and/or numeric format. Distance measuring is updated 10 times a second. Distance-to-go information is provided over the last 15 m of aircraft approach to the parking position in steps of 0.75 m. The distance-to-go indicator consists of three alphanumeric display panels forming a vertical bar. Each display panel is a 7 by 5 yellow fluorescent dot matrix. Illumination is provided by a fluorescent tube.

12.3.18 When the system is activated for docking, a distance sensor transmits laser pulses in the vertical plane to detect an approaching aircraft. When the laser pulses hit the aircraft, the pulses are reflected to the receiver. Distance measuring is performed 10 times per second. The system is able to detect an aircraft at more than 100 m distance. Data on distance measuring is sent to the control unit, which will process the data relative to the parking position prior to

distance-to-go information being presented on the display unit. The whole operation of collecting measuring data, processing the data and showing the information on the display unit takes less than 0.2 seconds.

12.3.19 The azimuth guidance indicator, based on the Moiré technique, provides the pilot with continuous and real-time azimuth guidance information. The azimuth guidance indicator consists of a front grating and a rear grating. Light passes through the superimposed gratings and creates a Moiré arrow pattern. Small relative movements between the gratings result in large changes in the pattern. Illumination is provided by compact fluorescent tubes. Reduced illumination is applied during night to prevent operational problems caused by glare.

12.3.20 When approaching the aircraft stand, the pilot steers the aircraft in the direction indicated by the arrow pattern until the arrow becomes a straight line. When the azimuth guidance display shows a straight vertical black line, the aircraft is established correctly on the centre line.

12.3.21 The control unit is based on an industrial control computer. Aircraft data, such as length, wing span, and distances to nose, pilot's eyes, nose wheel, main landing gear, and doors 1 and 2, for more than 500 different aircraft types and series are stored in the computer. Event-recording facilities may also be included in the control unit.

12.3.22 The visual guidance docking system can be interfaced with an airport operations database (AODB) or flight information display system (FIDS). It can thus provide the ground crew with flight information, such as the flight number, departure point and destination.

12.3.23 The system can be activated either automatically or from the operator control panel. Manual activation is carried out by selecting the incoming aircraft on the operator control panel. Automatic activation can be provided by connecting the system to the AODB/FIDS at the airport.

12.3.24 The system displays the aircraft type on the alphanumeric indicator. This gives the pilot the opportunity to halt the approach to its parking position if the aircraft type being processed in the system is incorrect.

12.3.25 During aircraft docking the system is being monitored and if a fault or operational error is detected, the alphanumeric indicator will display "STOP" and the error code and the operator control panel will display the error message.

12.3.26 The emergency stop button is used when the operator decides that the approaching aircraft is in jeopardy.

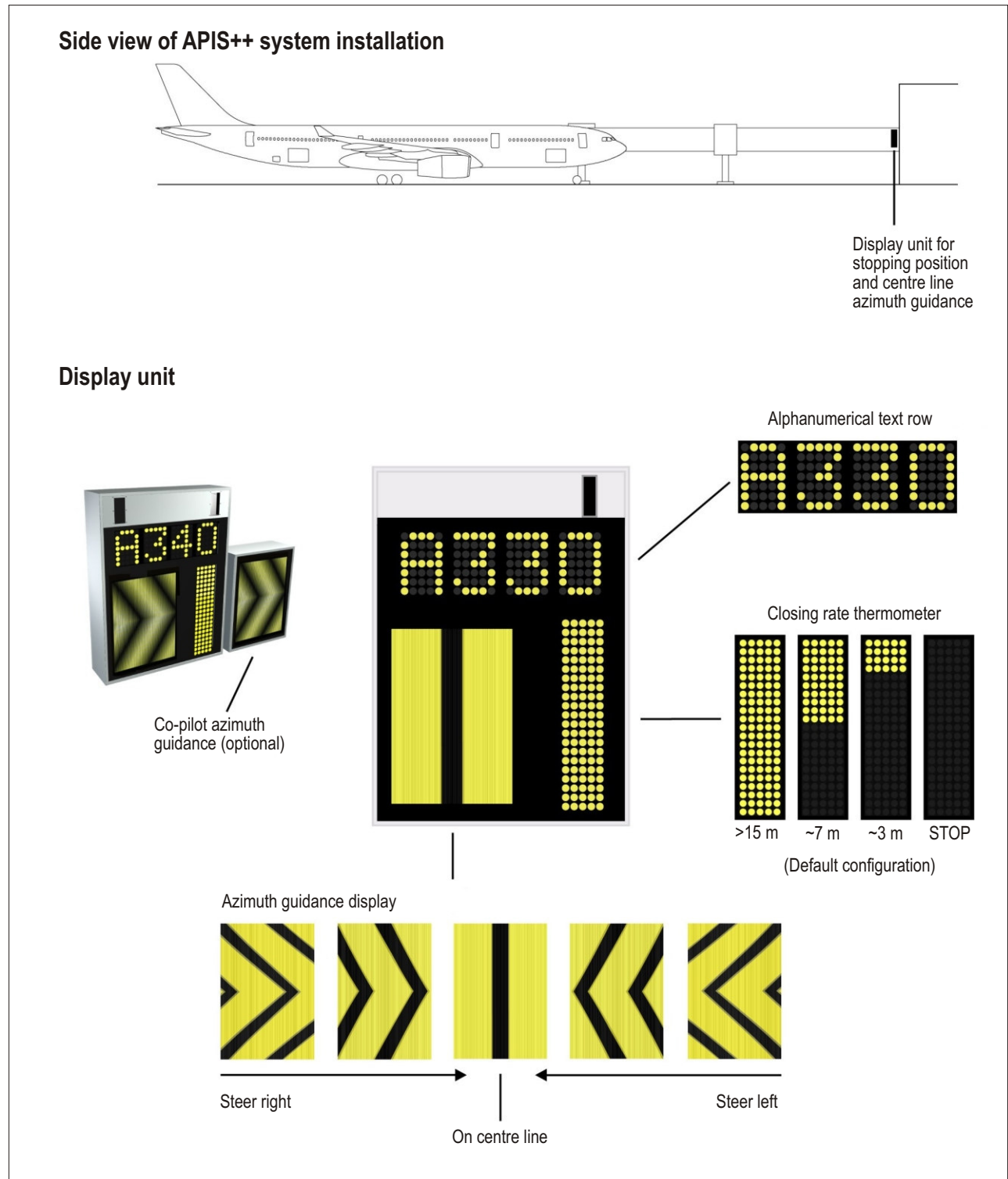

Figure 12-2. A visual docking guidance system using a graphical display (Moiré technique) to provide azimuth guidance and a laser radar to provide distance-to-go and stopping position information

When the emergency stop is activated, the visual docking guidance system will display azimuth guidance and distance-to-go information, and the alphanumeric indicator will display “STOP”. After a preset time period, the alphanumeric indicator will display “ESTP” (emergency stop) and “STOP” until the emergency stop button is released. During the time the emergency stop is activated, all interlocks to other stand equipment are normally released. When the emergency stop button is released, the system will revert to the status it had before the emergency stop was activated.

Systems using lights alone

12.3.27 A visual docking guidance system which uses lights alone to provide guidance is described in Figures 12-3 and 12-4. The system consists of two elements: an azimuth guidance unit and a stopping position indicator. The azimuth guidance unit is installed on the extension of the stand centre line ahead of the aircraft (see Figure 12-3). The stopping position indicator is also installed on the extension of the stand centre line, but it is not collocated with the azimuth guidance unit (see Figure 12-4).

12.3.28 The azimuth guidance unit functions as follows. If the stand centre line is taken as the origin, and angles located to the left of the stand centre line are considered as negative and those to the right as positive, the pilot gets the following five indications when facing the unit:

- a) from $-10^{\circ}37'$ to $-6^{\circ}37'$, the left beam is red and the right beam green;
- b) between $-6^{\circ}37'$ and $-0^{\circ}7'$, the left beam which was red throughout its height gradually turns green, whereas the right beam remains green;

- c) between $-0^{\circ}7'$ and $+0^{\circ}7'$, the two beams are green;
- d) between $+0^{\circ}7'$ and $+6^{\circ}37'$, the left beam remains green, while the right beam which was green throughout its height gradually turns red;
- e) between $+6^{\circ}37'$ and $+10^{\circ}37'$, the left beam is completely green and the right beam is completely red.

12.3.29 From the above it follows that, if the pilot sees two green beams throughout their height, the aircraft is on or close to the stand centre line. If the aircraft is to the left of the stand centre line, the pilot will see the left beam partially or totally red, depending on the extent of deviation, and the right beam green. The pilot must then move to the right in order to see both beams green. On the other hand, if the aircraft is to the right of the stand centre line, the pilot will see the right beam partially or totally red and the left beam green. The pilot must then move to the left to see both beams green.

12.3.30 The stopping position indicator of the system uses green and red colours to indicate the precise stopping positions. It is located in front of the pilot and above the pilot's eye height as indicated in Figure 12-4. The unit consists of an internally illuminated horizontal slot with three stopping positions marked on it. Each stopping position is identified by the type of aircraft to which it is applicable. When the aircraft enters the stand, the entire horizontal slot will appear green to the pilot. As the aircraft moves forward along the stand centre line, the left-hand portion of the slot becomes red and then the length of the red sector gradually increases. The aircraft reaches the stopping position when the interface of the red and green sectors is in line with the stop mark (on the slot) for that aircraft type.

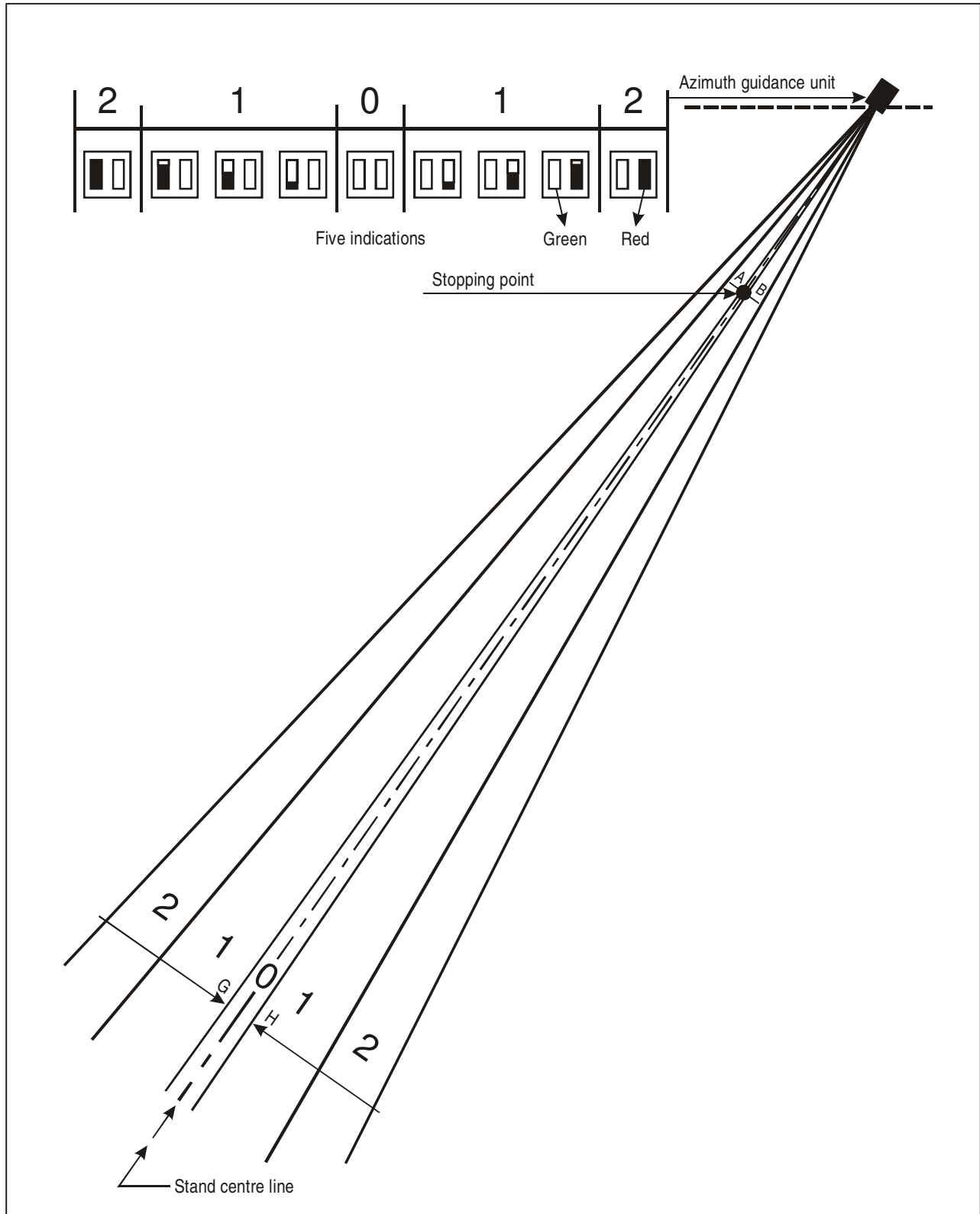

Figure 12-3. The azimuth guidance unit of a visual docking guidance system using lights

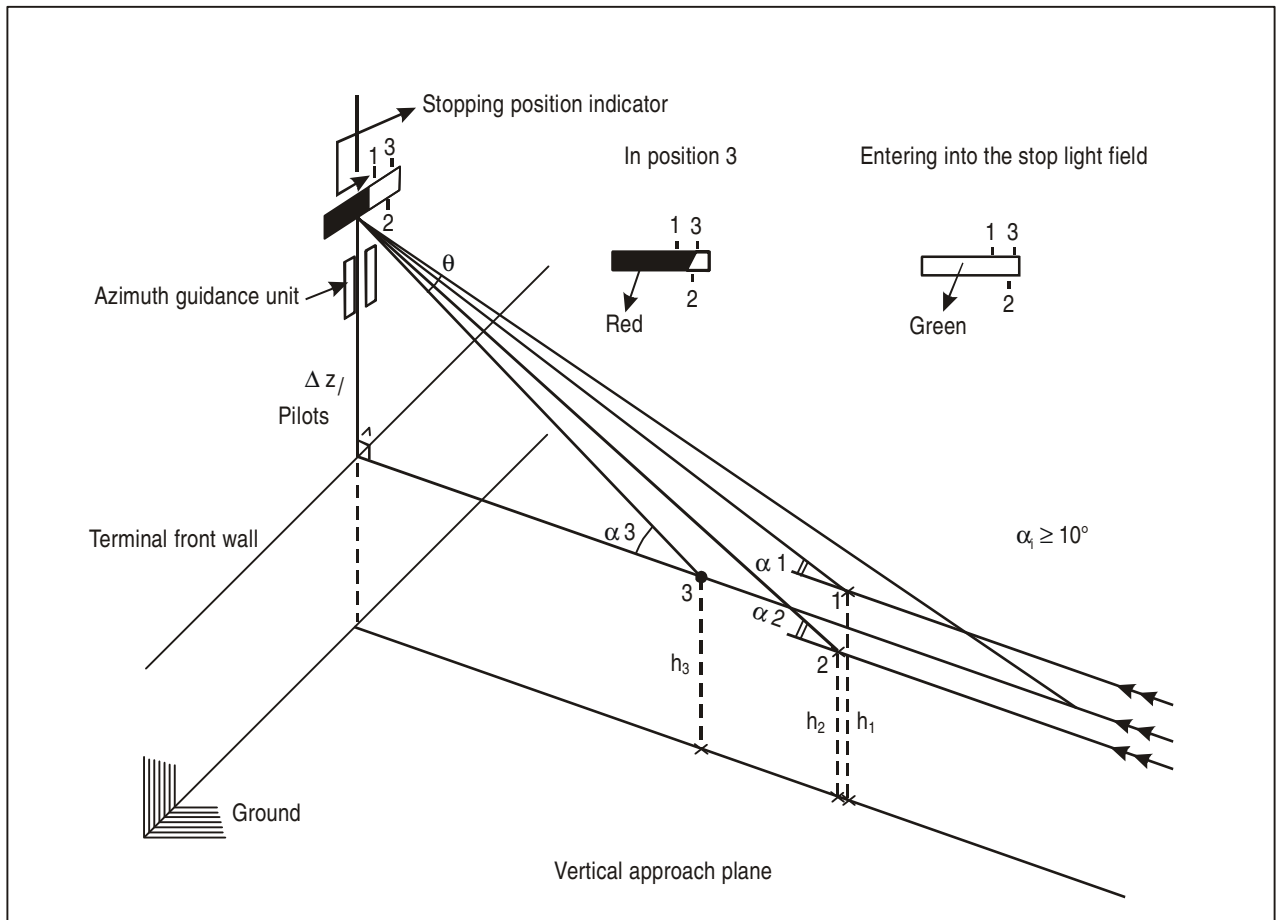

Figure 12-4. The stopping position indicator of a visual docking guidance system using lights

Chapter 13

Apron Floodlighting

13.1 INTRODUCTION

13.1.1 The following material is provided in order to give guidance in the application of Annex 14, Volume I, 5.3.21.

13.1.2 An apron is a defined area on a land aerodrome intended to accommodate aircraft for the purpose of loading and unloading passengers, mail or cargo; refuelling; parking or maintenance. Aircraft would normally be expected to move into these areas under their own power or by towing, and adequate lighting is necessary to enable these tasks to be performed safely and efficiently at night.

13.1.3 The part of the apron containing the aircraft stands requires a relatively high level of illuminance. The size of each aircraft stand is largely determined by the size of the aircraft and by the amount of space necessary to manoeuvre the aircraft safely into and out of this position.

13.2 FUNCTIONS

13.2.1 The primary functions of apron floodlighting are to:

- a) assist the pilot in taxiing the aircraft into and out of the final parking position;
- b) provide lighting suitable for passengers to embark and disembark and for personnel to load and unload cargo, refuel and perform other apron service functions; and
- c) maintain airport security.

Aircraft taxiing

13.2.2 The pilot mainly relies on apron floodlighting when taxiing on the apron. Uniform illuminance of the pave-

ment within the aircraft stand and elimination of glare are major requirements. On taxiways adjacent to aircraft stands, a lower illuminance is desirable in order to provide a gradual transition to the higher illuminance on the aircraft stands.

Apron service

13.2.3 These functions require uniform illuminance of the aircraft stand area of a sufficient level to perform most of the tasks. In case of unavoidable shadows, some tasks may require supplementary lighting.

Airport security

13.2.4 Illuminance should be sufficient to detect the presence of unauthorized persons on the apron and to enable identification of personnel on or near aircraft stands.

13.3 PERFORMANCE REQUIREMENTS

Choice of light source

13.3.1 Various light sources can be applied. The spectral distribution of these lights shall be such that all colours used for aircraft markings connected with routine servicing, and for surface and obstruction markings, can be correctly identified. Practice has shown that incandescent halogen, as well as different high-pressure gas discharge lamps, is suitable for this purpose. Discharge lamps, by the nature of their spectral distribution, will produce colour shifting. Therefore it is imperative to check the colours produced by these lamps under daylight as well as artificial light to ensure correct colour identification. Occasionally it may be advisable to adjust the colour scheme used for surface and obstruction markings. For economic reasons high-pressure sodium or high-pressure mercury halide lamps are recommended.

Illuminance

13.3.2 An average illuminance of not less than 20 lux is needed for colour perception and is considered the minimum requirement for the tasks to be carried out on the aircraft stands. In order to provide optimum visibility, it is essential that illuminance on the aircraft stand be uniform within a ratio of 4 to 1 (average to minimum). In this connection the average vertical illuminance at a height of 2 m should not be less than 20 lux in relevant directions.

13.3.3 To maintain acceptable visibility conditions, the average horizontal illuminance on the apron, except where service functions are taking place, should not be less than 50 per cent of the average horizontal illuminance of the aircraft stands, within a uniformity ratio of 4 to 1 (average to minimum) in this area.

13.3.4 It is recognized that some visual tasks require additional supplementary lighting, e.g. portable lighting. However, the use of vehicle headlights for purposes other than guidance during driving should be avoided.

13.3.5 For security reasons, additional illuminance greater than that specified above may be required.

13.3.6 The area between the aircraft stands and the apron limit (service equipment, parking area, service roads) should be illuminated to an average horizontal illuminance of 10 lux. If the higher-mounted floodlights do not light this area adequately, then glare-free lighting of the street-lighting type could be used. Some examples of illuminance on aprons are presented in Figures 13-1, 13-2, 13-3 and 13-4.

Glare

13.3.7 Direct lamplight from the floodlights shall be avoided in the direction of a control tower and landing aircraft. Aiming of floodlights should be, as far as practicable, in the directions away from a control tower or landing aircraft. Direct light above the horizontal plane through a floodlight should be restricted to the minimum (see Figures 13-5 and 13-6).

13.3.8 To minimize direct and indirect glare:

- a) the mounting height of the floodlights should be at least two times the maximum aircraft eye height of pilots of aircraft regularly using the airport (see Figure 13-6);
- b) the location and height of the masts should be such that inconvenience to ground personnel due to glare is kept to a minimum.

In order to meet these requirements, floodlights will have to be aimed carefully, giving due consideration to their light distribution. Light distribution may have to be adapted by the use of screens.

Emergency lighting

13.3.9 To cover the possibility of a power failure, it is recommended that provision be made for sufficient illumination to be available to ensure passenger safety (see also 13.4.3).

13.4 DESIGN CRITERIA

Lighting aspects

13.4.1 In addition to the design criteria derived from the performance requirements, the following aspects should be considered in designing an apron floodlighting system:

- a) the height of the apron floodlighting masts should be in accordance with the relevant obstacle clearance requirements as shown in Annex 14, Volume I, Chapter 4;
- b) obstructions in the view of control tower personnel should be avoided. In this respect special attention should be paid to the location and the height of the floodlighting towers; and
- c) the arrangement and aiming of floodlights should be such that aircraft stands receive light from different directions to minimize shadows. Better results are obtained by uniform illuminance of the total area than by directing individual floodlights at the aircraft (see Figures 13-7 and 13-8).

Physical aspects

13.4.2 During the design stage of an airport, due consideration should be given to the physical aspects of the apron in order to provide efficient apron floodlighting. The ultimate choice of the location and height of the floodlights depends upon:

- a) dimensions of apron(s);
- b) arrangement of aircraft stands;

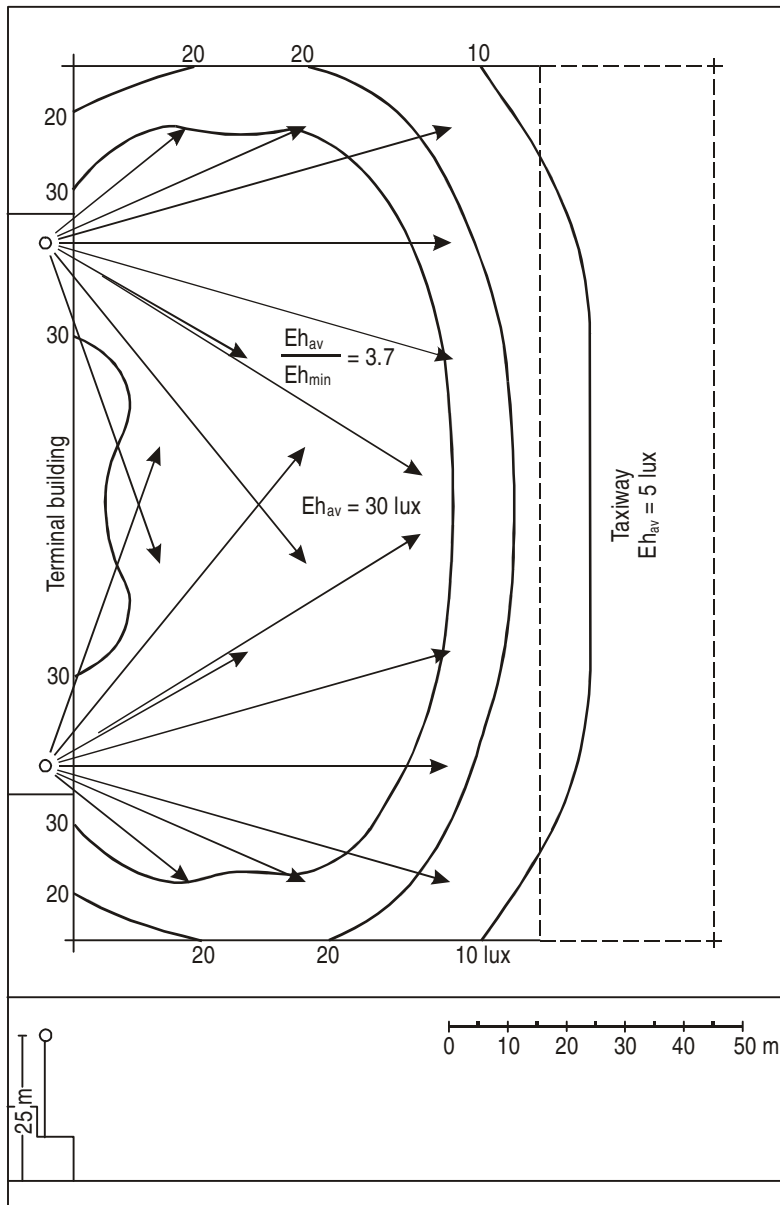

Figure 13-1. Typical isolux curves for horizontal illuminance (Example A)

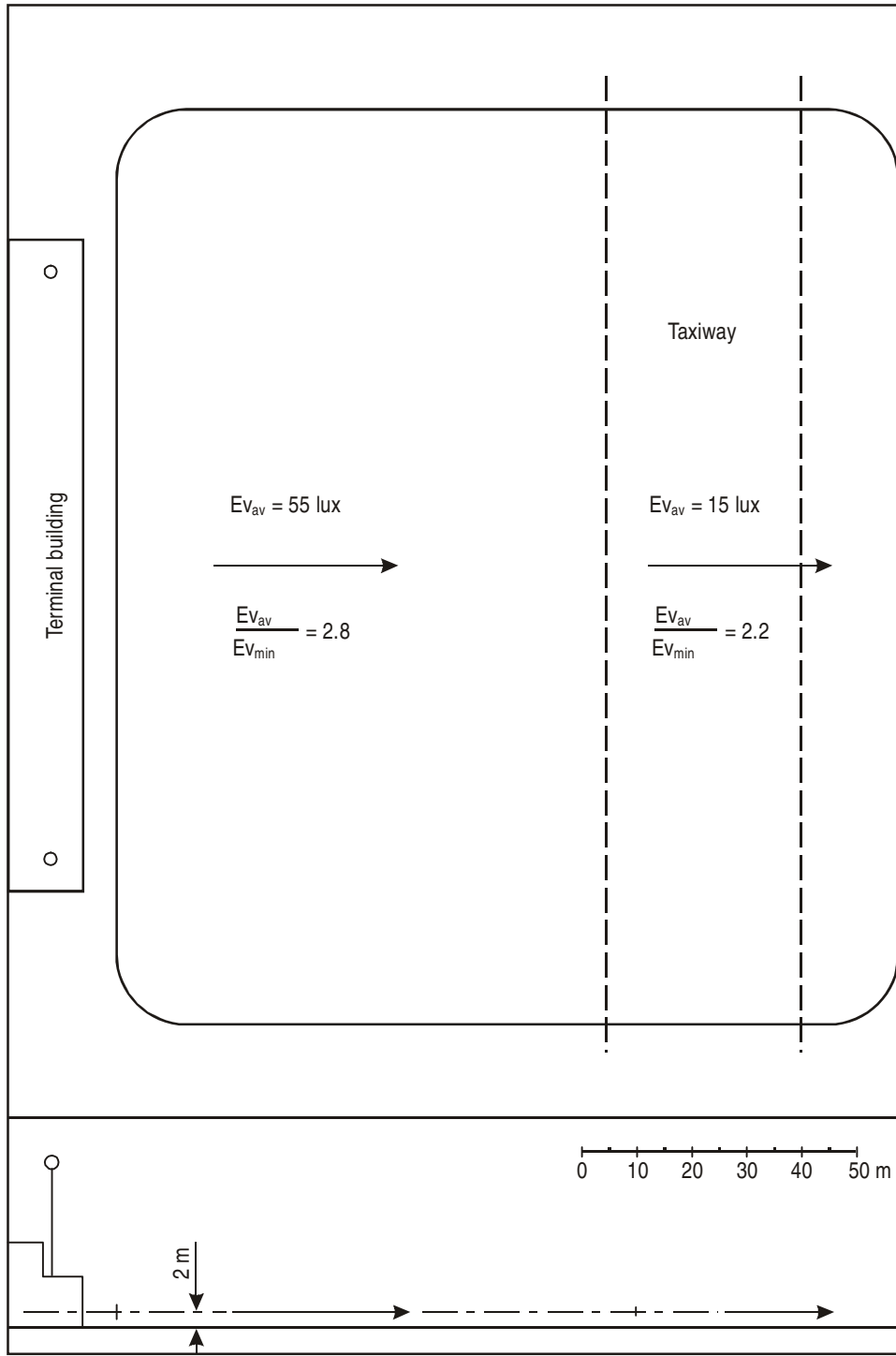

Figure 13-2. Typical average vertical illuminance at 2 m height (Example A)

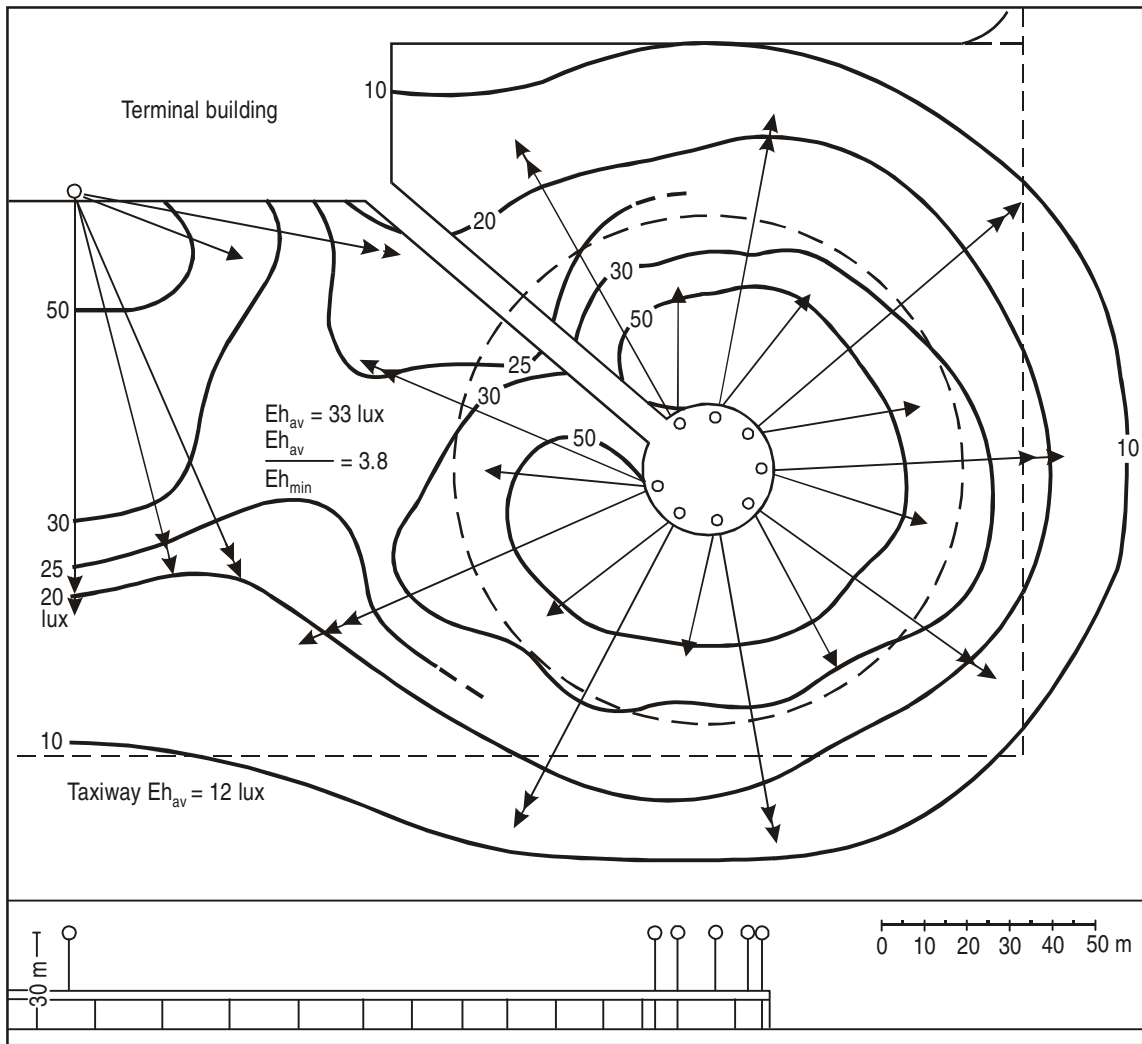

Figure 13-3. Typical isolux curves for horizontal illuminance (Example B)

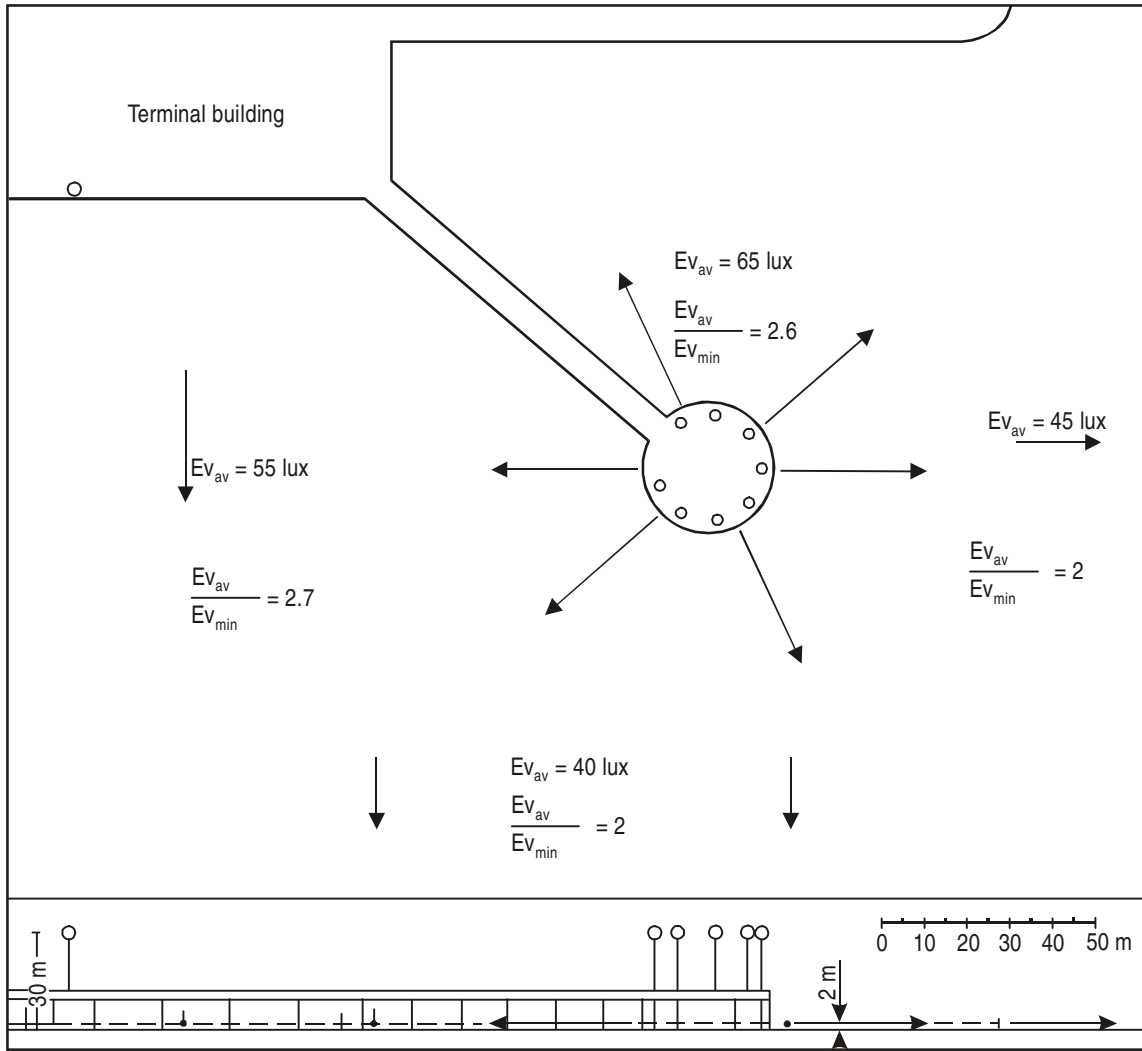

Figure 13-4. Typical average vertical illuminance at 2 m height (Example B)

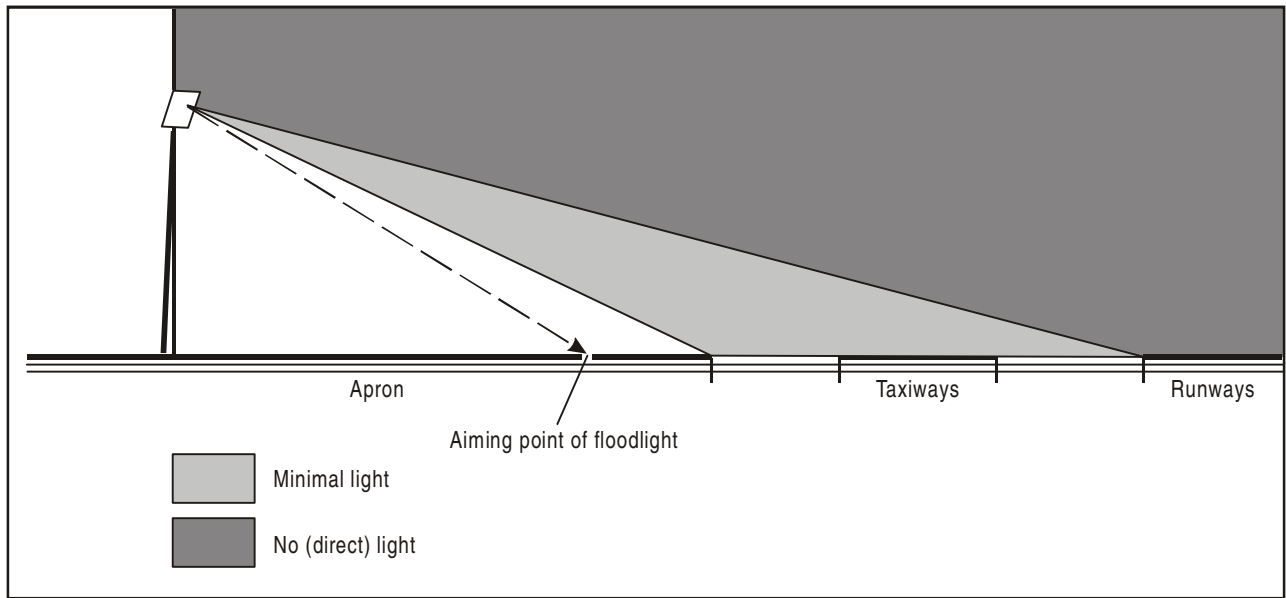

Figure 13-5. Aiming to avoid glare

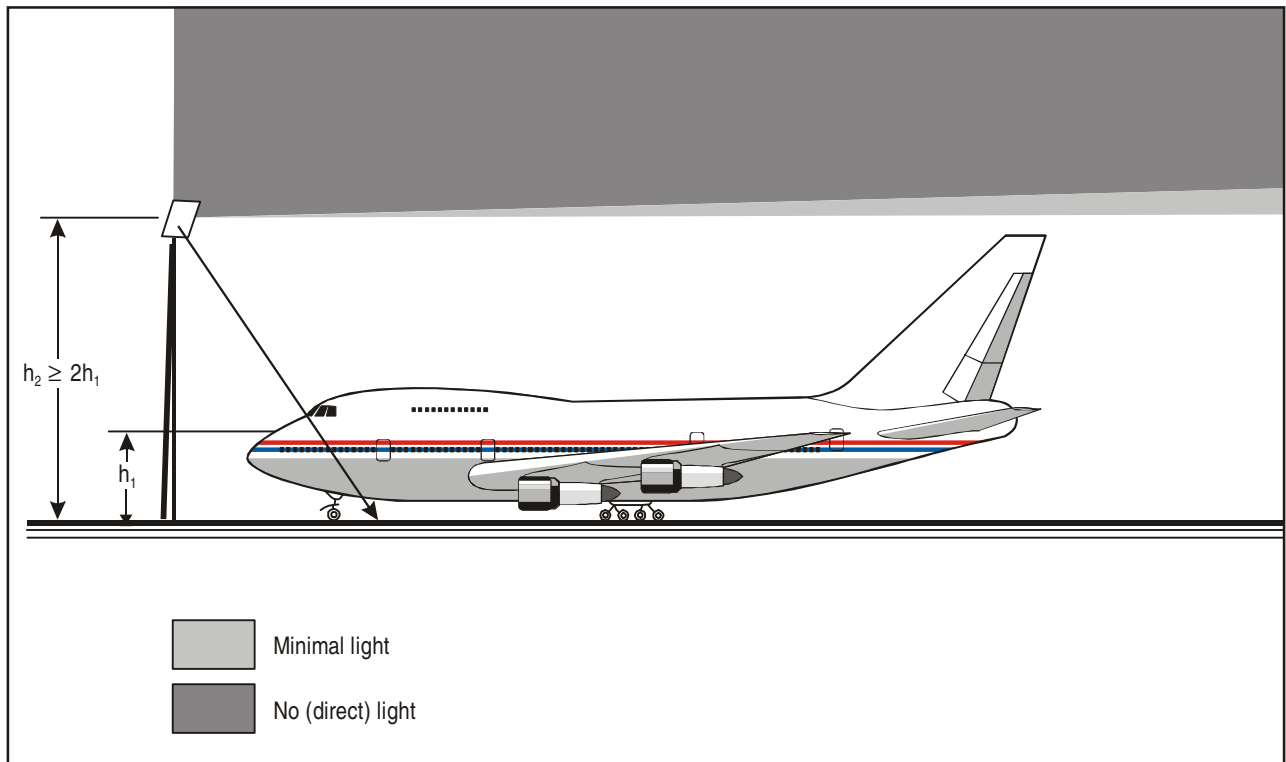

Figure 13-6. Mounting height to avoid glare

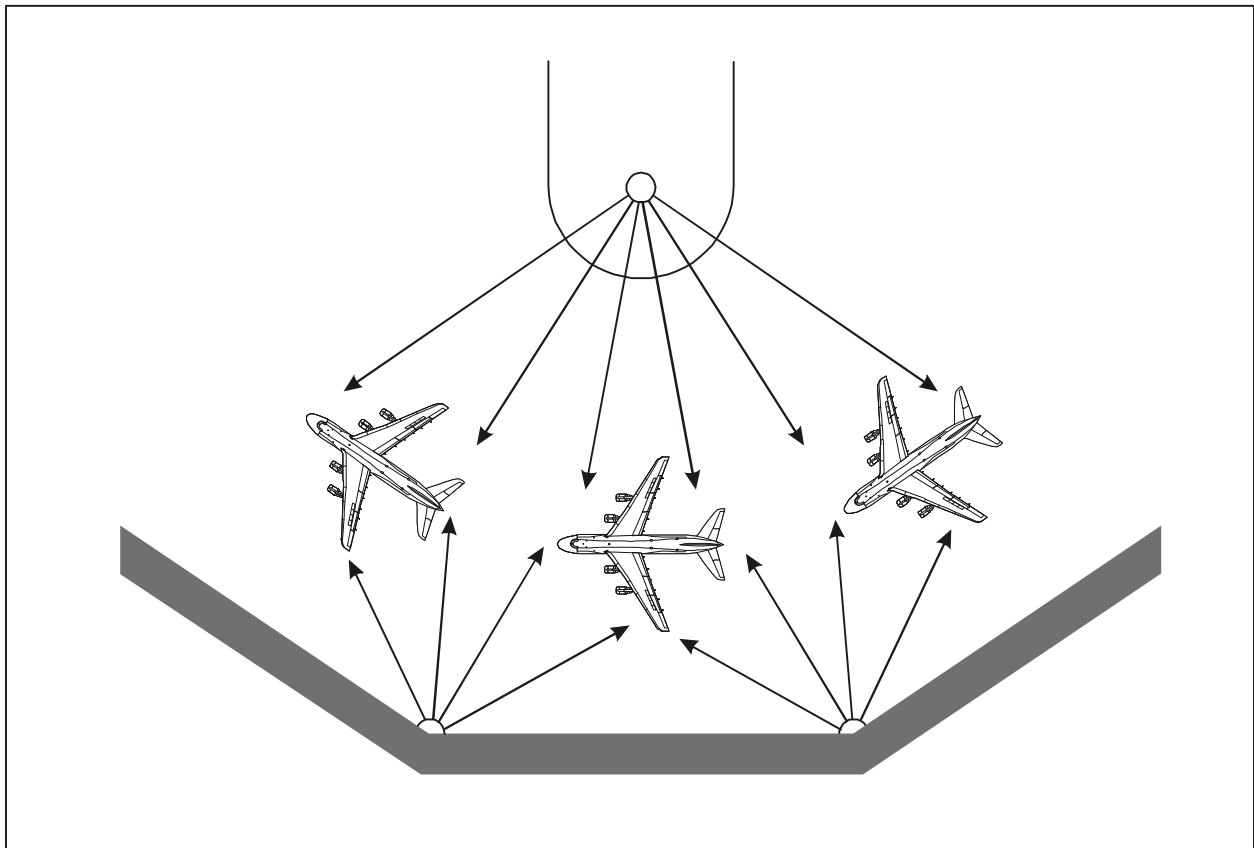

Figure 13-7. Typical floodlight arrangement and aiming for parallel parking

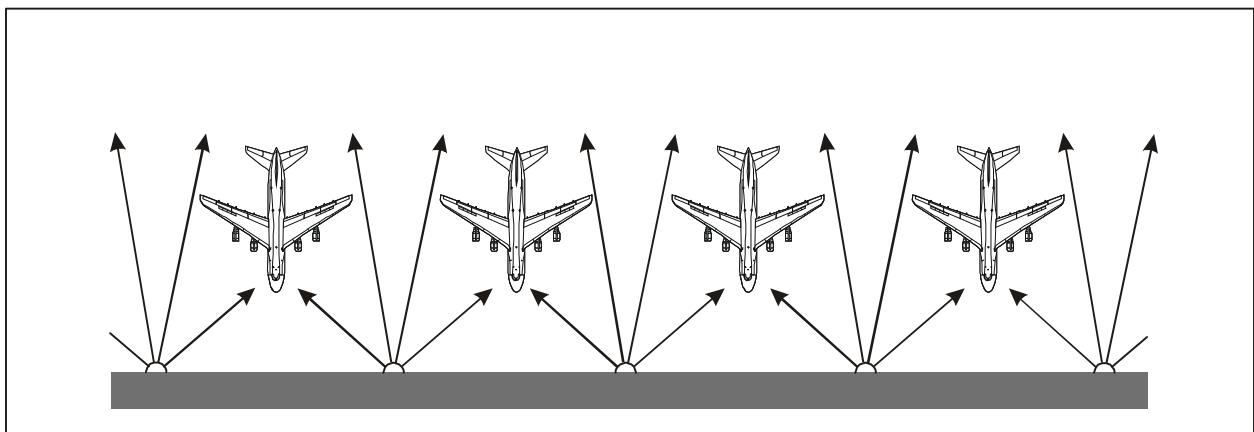

Figure 13-8. Typical floodlight arrangement and aiming for nose-in parking

- c) taxiway arrangement and traffic scheme;
- d) adjacent areas and buildings, especially control tower(s); and
- e) location and status of runway(s) and helicopter landing areas.

Note.— Guidance material concerning the dimensions of apron and parking stands will be found in the Aerodrome Design Manual, Doc 9157, Part 2.

Electrical aspects

13.4.3 If discharge lamps are used, a three-phase electrical supply system should be utilized to avoid strobo-

scopic effects. If high-pressure discharge lamps are used, emergency lighting can be arranged by either halogen incandescent lamps or by special circuitry of some of the high-pressure discharge lamps.

Maintenance aspects

13.4.4 The lighting system should be so designed that maintenance expense can be held to a reasonable value. If access to lights is difficult, it is most economical to change lamps on a group replacement basis. Since the cost of replacing lamps in high-mounted lights can be significant, long-life lamps should be used. Where possible, the lights should be so placed that they will be easily accessible without using special equipment. Tall poles could be equipped with polesteps or raising and lowering devices for servicing.

Chapter 14

Marking and Lighting of Obstacles

14.1 GENERAL

Operational requirements

14.1.1 The safety of flying at low levels under visual flight rules (VFR) depends significantly on the pilot being able to see any obstruction that constitutes an obstacle to flight in sufficient time to carry out an evasive manoeuvre in an unhurried and controlled manner. The most demanding circumstances occur when flights take place in a visibility close to the limiting value for that class of operation. Obstacles cannot be seen at ranges in excess of the prevailing visibility and will often be seen at lesser ranges. The shortfall in obstacle range performance is what constitutes the flight hazard. In practical terms, flight safety considerations require the conspicuity of obstacles to be enhanced so that their visual range is at least the same as the prevailing visibility in marginal weather conditions.

14.1.2 At night, similar considerations arise. Pilots have the same need to see obstacles in sufficient time to carry out any necessary evasive manoeuvre.

14.1.3 In all circumstances, pilots should be able to determine the location and extent of the obstacle. By night, this always requires the application of measures to delineate the obstacle in some detail. By day, enhancement of the cues that enable the obstacle to be located easily is important, but in many circumstances cue enhancements to delineate the extent of the obstruction are not essential. In the daytime, if the pilot can see the obstacle, then in many circumstances the size and shape can also be readily appreciated.

14.1.4 In one State, it is assumed that pilots of aircraft travelling at 165 kt or less should be able to see obstruction lights in sufficient time to avoid the structure by at least 600 m horizontally under all conditions of operation. Pilots operating between 165 kt and 250 kt should be able to see the obstruction lights at 1.9 km, unless the weather deteriorates to 1.5 km visibility at night during which time

2 000 cd would be required to see the lights at the same distance. A higher intensity with greater visibility at night can generate an annoying signal to local residents. In addition, aircraft in these speed ranges can normally be expected to operate under instrument flight rules (IFR) at night when the visibility is 1.5 km.

14.1.5 In another State, the rationale for the identification of the required obstacle light intensity is based on the assumption that lights should have a range equal to the lowest visibility in which a pilot can fly under VFR, i.e. 3.7 km.

Types of obstacles

14.1.6 Obstacles can be created in both the aerodrome and en-route environments by a range of structures; some of the most common are transmission masts, pylons, bridges, cooling towers, communication masts and cables. All such obstacles are within the purview of Annex 14, Volume I, although those specifications are specifically published in relation to aerodrome operations.

Implementation

14.1.7 Many obstacles are considered by residents to have a negative visual impact on the local environment. Operational requirements are therefore inevitably influenced by a conflict of interests in that pilots require enhancement of the conspicuity of obstacles whilst environmentalists require that obstacles should be inconspicuous. The basic requirement is therefore to make obstacles conspicuous when viewed from aircraft without significantly increasing the conspicuity of obstacles when viewed from the ground.

14.1.8 The method of obstacle visibility enhancement chosen must be capable of operating effectively at all times. A high level of reliability and availability is therefore required, implying that the characteristics of the system that is installed must be capable of being maintained over prolonged periods.

14.2 CONSPICUITY ENHANCEMENT TECHNIQUES

14.2.1 The techniques recommended in Annex 14, Volume I, Chapter 6, for the enhancement of obstacle conspicuity fall mainly into two categories, marking and lighting. A third method in which the size of the obstacle is increased by attaching additional structural material is also used in some applications. An example of this latter method is the placing of spheres at intervals along cables. The marking of surfaces of obstacles with large alternating areas of contrasting colour chosen to produce bands or squares of high or low reflectance is a requirement that is particularly applied to obstacles such as buildings, masts and towers. When first applied to the structure, such colouring media can be effective in making the obstacle conspicuous by day over a wide range of viewing conditions. However, the cost and difficulty of maintaining the initial characteristics of this solution are significant. Furthermore, at night the system must be supplemented by a lighting installation.

14.2.2 Lighting systems that are operationally effective are extensively used. These systems provide pilots with adequate information on the location and extent of the objects to which they are applied. Experience has shown that, at night, steady lights of an appropriate colour and intensity meet operational requirements in a manner that satisfies both pilots and local residents.

14.2.3 The recommended practices for enhancing the conspicuity of obstacles have a number of practical difficulties associated with them. As already mentioned, the enhancement of contrast through use of paint, or similar colouring materials, is only effective for day flying and must always be supplemented by lighting at night. Application and maintenance costs are high, and these problems are exacerbated by access issues, particularly on tall structures.

14.2.4 Whilst patterns of steady red lights can be provided that adequately indicate obstacles to pilots at night, by day the intensity of the lights has to be substantially increased to produce the same range performance. Signals having these high levels of output can, in practice, only be provided by the use of white flashing lights. Lights of this type are used extensively in some States. The size and weight of the equipment for this type of lighting make it impracticable to apply this solution to some obstacles. Furthermore, the signal characteristics of flashing lights are not acceptable to some local residents in daytime and are strongly objected to in many locations at night, even if the intensity levels are reduced. These adverse conditions cause

particular difficulties away from urban environments where ambient light levels are generally low.

14.3 MARKING

14.3.1 The circumstances in which an obstacle should be marked and techniques for the application of markings are described in Annex 14, Volume I, Chapter 6. The techniques that are used are those that overall provide the best enhancement of the conspicuity of objects, although they are not effective in some circumstances.

14.3.2 If an object is viewed against a sky background, the greatest range will be achieved if the object is black. In overcast conditions, objects that are coloured orange can have a visual range which almost matches that obtained with black. In sunny conditions, when flying down sun, black, orange or white surfaces all produce similar and useful visual ranges. When flying up sun, the contrast associated with orange is reduced but that of white increases. Thus, for identical objects an orange and white paint scheme is generally as effective as black. Furthermore, when viewed against a complex terrestrial background, the orange and white colour scheme provides significant operational contact range benefits.

14.3.3 By day, it is theoretically possible to match or exceed the range of coloured objects with a suitably specified light. To achieve operationally significant range benefits in all daytime weather conditions requires the use of intensities that are not practical in some applications. This is particularly true for small structures where the size and weight of the light units makes such solutions impracticable.

14.3.4 The visual range of a tall, slender lattice structure, such as a radio or television mast, is a complex function of the reflectance of the structural members, their area and spacing, the sky conditions, the direction of the sun, the direction from which the mast is viewed, as well as the transmissivity of the atmosphere and the background against which it is seen. When the visual range of the mast is low, the structural members of the tower can be resolved by a pilot even when viewing the object at the limit of visibility. On the other hand, when the visual range is great, the structural members cannot be resolved and the mast must be considered as a large object having low contrast with the background. In this case, the contrast is determined from the average brightness of the overall area of the mast, the structural members and background within the envelope of the mast.

14.4 LIGHTING CHARACTERISTICS

14.4.1 The characteristics of obstacle lighting are specified in Annex 14, Volume I, Table 6-3 and Appendix 6. Depending on the particular application low-, medium- or high-intensity lights are required. In some circumstances, a combination of light types is used.

14.4.2 Obstacle lights emit either white or red light except for one application where blue light may be used. Some types of lights provide a steady signal, other types have a flashing characteristic. Where a flashing light is used, the repetition rate is specified. This varies between types of lights.

14.4.3 To provide pilots with the optimal signal, the repetition rate should be approximately 90 flashes per minute. Rates between 60 and 120 flashes per minute are generally assessed by pilots as providing the necessary conspicuous signal. These rates ensure that contact can be maintained with the lights after initial acquisition. Lower frequencies result in there being an undesirably long interval between signals. This makes the lights difficult to locate and retain in the instantaneous field of view of the pilot. Design considerations may result in the use of repetition rates that are less than the optimum values, but such lights are still found to be operationally effective. Conversely, frequencies higher than these values can be annoying to any observer.

14.4.4 Obstacle lighting should be visible at all angles of azimuth. Achievement of this characteristic necessitates the use of multiple fittings in applications such as cooling towers. The vertical beam spread specified ensures that sufficient lights can be seen by pilots to identify the location and extent of any object that is an obstacle to the safe navigation of aircraft.

14.4.5 The intensities specified in Annex 14, Volume I, Table 6-3, have been chosen to give an adequate visual range in the most demanding conditions in which it is intended the lights shall be used. The relationship between intensity and visual range for a number of circumstances is shown in Table 14-1. The intensities shown cover the full range of high, medium and low intensities used in the provision of obstacle lighting.

14.4.6 The operational benefits of high-intensity lighting in day conditions are illustrated in Figure 14-1. Range performance data for lights of 200 000 cd, 20 000 cd and 2 000 cd are presented for a range of meteorological conditions.

14.4.7 To be of operational benefit, a light must produce a visual range in excess of the range of the unlit object on which it is located. The unlit range of the object may be equal to the meteorological visibility. By definition, it can never be greater and in practice it will often be less. For specification and design purposes, it can be assumed

Table 14-1. Relationship between intensity and visual range

Time period	Meteorological visibility (km)	Distance (km)	Intensity (cd)
Day	1.6	2.4	200 000 ± 25%
		2.2	100 000 ± 25%
		1.6	20 000 ± 25%
Day	4.8	4.8	200 000 ± 25%
		4.3	100 000 ± 25%
		2.9	20 000 ± 25%
Twilight	1.6	1.6 to 2.4	20 000 ± 25%
Twilight	4.8	2.9 to 6.7	20 000 ± 25%
Night	1.6	1.9	2 000 ± 25%
		1.8	1 500 ± 25%
		1.0	32 ± 25%
Night	4.8	4.9	2 000 ± 25%
		4.7	1 500 ± 25%
		1.4	32 ± 25%

that the requirement is such that the range of the light must be greater than the range of the unlit obstacle.

14.4.8 High-intensity lights (200 000 cd) produce the required range enhancement over the full spread of operationally significant distances. At all the ranges above approximately 6 km, the visual range of high-intensity lights tends to be less than the meteorological (obstacle) range, but at these distances no enhancement of the naturally occurring visual cues is generally necessary.

14.4.9 Environmental problems with the use of obstacle lighting have been identified. The scale of the problem is dependent on the location of the obstacle. Certain areas are more sensitive to environmental concerns. These areas include suburbs, national parks, valleys and locations where lights are placed on buildings of historic or architectural significance. The light characteristics which in combination can produce the subjective difference between environmentally objectionable and environmentally acceptable solutions include:

- a) colour;
- b) intensity in the direction of the viewer;
- c) flash characteristics; and
- d) lighting configuration on the structure.

The environmental acceptability of various colours of lights is another issue. It is generally agreed that aviation red obstacle lights are less objectionable at ground level than flashing-white obstacle lights.

14.4.10 The intensity of the light in the direction of the viewer is a major determinant of the environmental acceptability of flashing-white lights at night. The amount of ground illumination is determined by several factors including:

- a) beam pattern;
- b) height of the light fixture above the ground;
- c) distance from the obstacle to the observer;
- d) meteorological visibility conditions; and
- e) aiming adjustments on the light fixture.

14.4.11 As can be seen from Figure 14-1, low-intensity lights provide no operational benefit by day. Except in very

low visibilities, where VFR operations do not take place, low-intensity lights have range characteristics that are inferior to the meteorological range.

14.4.12 Medium-intensity lighting (20 000 cd) can produce small beneficial range enhancements in poor to medium visibility conditions. In these circumstances, this type of lighting can be regarded as having a range performance that equates to the visibility of a painted object. This equivalence makes medium-intensity lighting a useful alternative to marking the object. The flashing characteristic of this lighting is beneficial in that it enhances the conspicuity of the obstacle by drawing the pilot's attention to the location of the obstacle.

14.4.13 The painting of markings on any structure is an expensive and potentially hazardous activity. To be operationally effective, the markings must always be maintained to a high standard. This is also an expensive requirement to comply with. The use of medium-intensity lighting in these circumstances often has clear cost-benefits. In addition, the light units are less expensive, smaller, of lower weight and use less power than the alternative high-intensity light units. There are many structures where it is impracticable to fit high-intensity lights.

14.4.14 In daytime conditions where an obstacle must be made conspicuous at short and medium ranges, but where the naturally occurring visual range of the object is sufficient at long range, medium-intensity lights offer a viable alternative to marking.

14.4.15 There are four types of low-intensity lighting specified, all for use in twilight and night conditions, although the intensities specified for the Type C and D lights are sufficient to make them clearly visible by day at the short ranges which they are used. For example, the Type D "follow me" vehicle lights will normally be used at ranges less than 100 m. There are two low-intensity lights, Type A and Type B, specified for the marking of fixed obstacles. Type A is normally used singly or in a pattern where only night lighting is required. The operational effectiveness of this light, particularly on and around aerodromes, has been demonstrated by many years of use.

14.4.16 The low-intensity light, Type B, was developed for use with the medium-intensity light, Type A, in a dual lighting system that provides implementation options in terms of practicability and environmental concerns.

14.4.17 In environments where the presence of other lighting noticeably affects the conspicuity of the

low-intensity light, Type A, consideration can be given to the use of the low-intensity light, Type B.

14.4.18 The following three types of medium-intensity lights are specified in Annex 14, Volume I, Table 6-3:

- a) Type A — medium-intensity flashing-white light;
- b) Type B — medium-intensity flashing-red light; and

c) Type C — medium-intensity fixed-red light.

14.4.19 The medium-intensity light, Type A, is designed for use in day, twilight and night conditions. In the latter condition, the output of the light is adjusted to 10 per cent of the full intensity. An intensity of 20 000 cd is not required at night to make the light effective and if used can result in operational difficulties caused by glare or environmental restrictions. This type of light can be used alone to provide a warning signal by day and by night. The

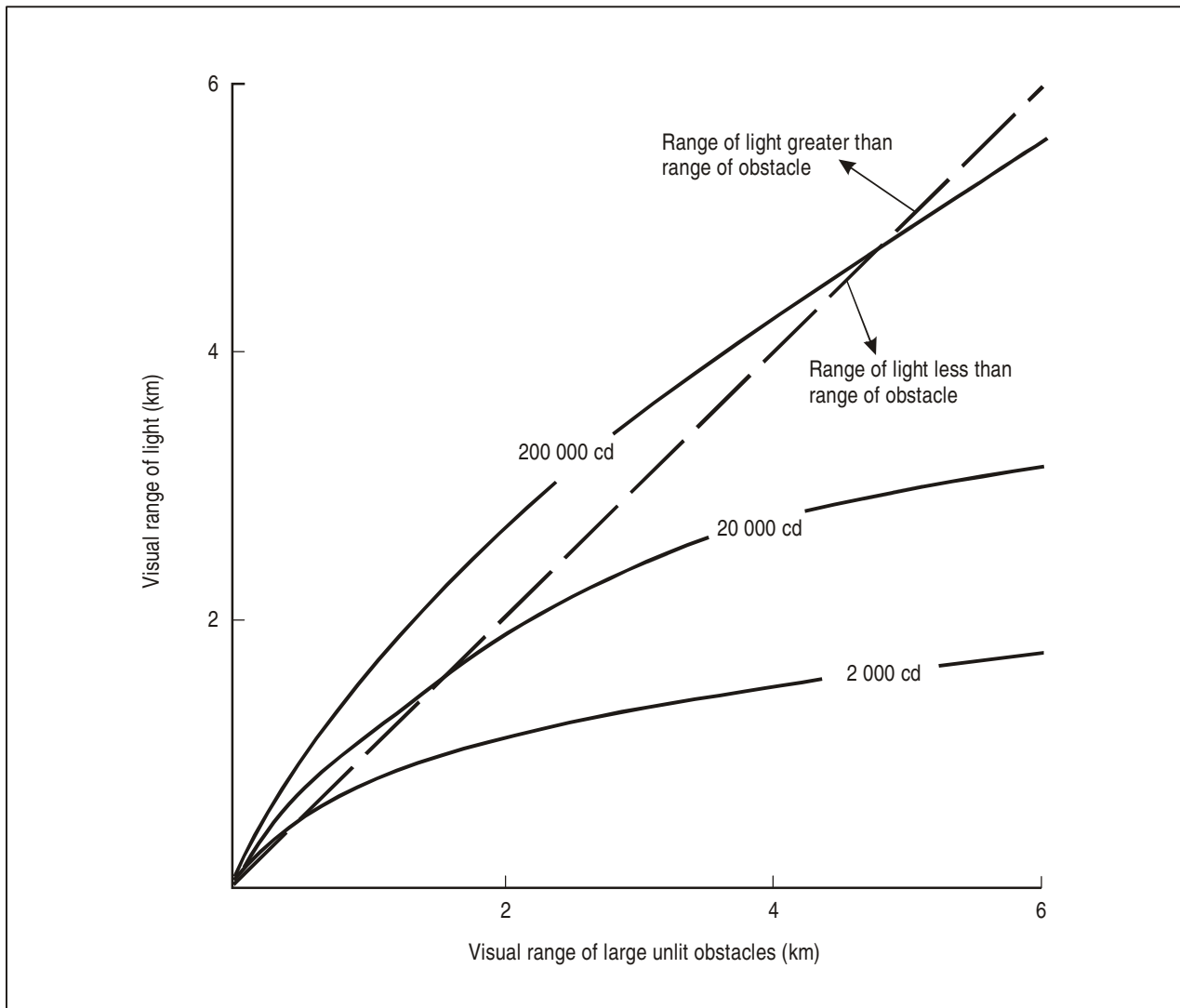

Figure 14-1. Comparison of the typical daytime range of lights and the range of large unlit objects for three values of intensity

Type A light is installed where there is an operational need to mark or light an obstacle, where it is not practicable or not necessary to install high-intensity lighting and where markings would be difficult to maintain. The Type A light does not have the range performance of high-intensity lighting, but there are many applications where an environmental study can show that it is not necessary to install the high-intensity equipment and that the range performance of the medium-intensity lighting is adequate.

14.4.20 The medium-intensity light, Type B, was developed specifically for use in dual lighting systems. It has the same intensity (2 000 cd) as the medium-intensity light, Type A, and the night setting of high-intensity lights, Types A and B, but because it emits red light it overcomes the objection to the use of flashing-white lights at night which occurs with other systems. Because it is medium power and requires no intensity control, the cost of the Type B light makes the use of dual lighting systems economically viable.

14.4.21 The medium-intensity light, Type B, is used in combination with high-intensity and low-intensity lights to provide dual systems that fulfil a number of different requirements.

14.4.22 The medium-intensity light, Type C, is designed for night use. It is used particularly where environmental issues prevent the use of white or flashing light signals. This type of light is an effective means of lighting obstacles in an urban environment where the large amount and colour of the lighting provides a difficult background for the obstacle lighting to be seen against. Red lights of 2 000 cd meet this requirement. The continuous nature of the signal is of particular benefit in this type of environment by making it easier for a pilot to retain visual contact with the obstacle after initial acquisition.

14.4.23 The high-intensity lights, Types A and B, have sufficient intensity to meet the most demanding daytime requirements. The intensity settings for twilight and night (background luminances of 50 to 500 cd/m² and less than 50 cd/m² respectively) provide appropriate lower levels of output. When specifying these types of light, it is necessary not only to consider the operational requirement for high intensities but also to consider the size and weight of the equipment. Whereas other types of lighting have a horizontal coverage of 360 degrees, high-intensity lighting usually consists of units having a horizontal coverage of approximately 120 degrees. It is therefore necessary to install a number of units at each light position to obtain all-round coverage.

14.5 LOCATION OF LIGHTING

14.5.1 The lighting specified in Annex 14, Volume I, Chapter 6, 6.3, provides for a number of system designs. This range of options is necessary to deal with the wide variety of operational systems in an appropriate manner.

14.5.2 The pattern of lights to be used and the location of the lights within the pattern is an important design consideration. It is only through the correct choice of pattern and light type within the pattern that an obstacle lighting system can fulfil the operational need.

14.5.3 For small objects less than 45 m in height, low-intensity lights are normally used. For more extensive objects and for objects having heights greater than 45 m, the use of medium-intensity lights is recommended. For objects extending more than 150 m above the surrounding ground level, high-intensity obstacle lights will normally be used to meet the operational requirements.

14.5.4 In all cases, a light should be installed as close as is practicable to the highest point on any object regardless of what other lights are provided.

14.5.5 For extensive objects such as a group of buildings, obstacle lights should be positioned to draw attention to the location of all primary corners and edges. When designing systems for night use, it is particularly important to ensure that the position and the extent of the object can be recognized by a pilot. Defining straight lines and corners by an adequate pattern of lights is particularly helpful.

14.5.6 An example of an obstacle lighting system for an extensive object is given in Annex 14, Volume I, Chapter 6, Figure 6-3. This figure shows how lighting can be applied to delineate the objects that constitute the obstruction.

14.5.7 Each obstacle should be the subject of a design study to identify the required layout for that particular situation. The design should conform to the recommendations given in Annex 14, Volume I, 6.3, which also provides examples of obstacle lighting systems for tall structures such as masts and chimneys. In some instances, these can extend to heights in excess of 600 m. Heights of approximately 250 m are common for TV antenna masts. The examples given in Annex 14, Volume I, Appendix 6, show how lighting can be selected and applied to meet a wide range of operational situations.

14.5.8 In Annex 14, Volume I, Appendix 6, Figure 6.1, the location details are given for a medium-intensity lighting system. This design can be adopted for obstacles such as communication masts. If the mast has a height in excess of 150 m, consideration should be given to the use of high-intensity lighting. For this case, marking is required if high-intensity lighting is not used. The medium-intensity lighting, Type A, is particularly useful on skeletal masts where weight-carrying capacity is limited and where access for maintenance purposes is not easy to achieve. The design of this layout follows a number of design guidelines. There is a light at the highest point of the structure for all masts 45 m or greater in height. There are at least two lights in the pattern for all masts of 105 m or greater in height. The lights in the pattern are equi-spaced and the space between them is never greater than 105 m. The lowest light is always at or below 105 m.

14.5.9 Annex 14, Volume I, Appendix 6, Figure 6.2, is an example of a dual lighting system suitable for night use only. The pattern consists of alternating 2 000 cd flashing-red and 32 cd fixed-red lights. The low-intensity lights are interspersed between the medium-intensity units, which are spaced in accordance with the parameters given in Annex 14, Volume I, 6.3.17. The flashing lights make this layout conspicuous, but their repetition rate is low. Once the pilot has located the obstacle, the low-intensity fixed lights present a continuous pattern that helps the pilot to retain an awareness of the obstacle. Without this feature, experience has shown that it is possible for a pilot to have only intermittent contact with the obstacle due to the low repetition rate of the flashing light signal. Continuity of visual information is an important requirement that cannot be met solely by lights having low repetition rates. An obstacle lit as shown in Annex 14, Volume I, Appendix 6, Figure 6.2, should be marked for daytime in conformity with Annex 14, Volume I, Chapter 6, 6.2.

14.5.10 Where a medium-intensity lighting system using only fixed-red lights is required, the layout shown in Annex 14, Volume I, Appendix 6, Figure 6.3, should be used. The light spacing is chosen to ensure that enough lights are placed on the obstacle to make both the location and the extent of the obstacle easy to determine. Operational experience has shown that this configuration provides the cues required by pilots without causing any environmental problems.

14.5.11 The dual lighting system defined in Annex 14, Volume I, Appendix 6, Figure 6.4, uses a combination of medium-intensity and low-intensity lighting. For daytime use, medium-intensity lights, Type A, must be

operated. At night, medium-intensity lights, Type B, are used augmented by low-intensity lights, Type B. In practice, this configuration results in a pattern of 20 000 cd flashing-white lights spaced at intervals of not more than 105 m for daytime use and a pattern of alternate flashing 2 000 cd and fixed 200 cd red lights at night with a spacing half that used for daytime operations. This arrangement is therefore identical to that provided in Annex 14, Volume I, Appendix 6, Figures 6.1 and 6.2 for daytime and for night operations, respectively. The lighting design is particularly useful for objects less than 150 m in height where there is a preference for flashing-white lights by day and flashing-red lights at night.

14.5.12 Another dual lighting system is defined in Annex 14, Volume I, Appendix 6, Figure 6.5. It uses medium-intensity lights, Type C (fixed-red), to provide a night capability identical to that provided in Annex 14, Volume I, Appendix 6, Figure 6.3. By the addition of medium-intensity lights, Type A, at alternate positions on the obstacle, a daytime capability using 20 000 cd flashing-white lights is added. The key features of this dual lighting system are the use of flashing-white lights by day and the use of only fixed-red (2 000 cd) lights by night. This configuration allows the use of medium-intensity flashing-white lights by day, but is acceptable at night in locations where both white lights and flashing signals are not acceptable. As with other designs using medium-intensity lights, Type A, it is primarily intended for use on obstacles less than 150 m high.

14.5.13 Where the warning information available from high-intensity lighting must be provided on tall structures, the design guidance given in Annex 14, Volume I, Appendix 6, Figures 6.6 to 6.8, is used. More detailed guidance on the installation of this type of lighting is given in 14.6 below, while Annex 14, Volume I, Appendix 6, Figure 6.6, gives the basic configuration. In Annex 14, Volume I, Appendix 6, Figures 6.7 and 6.8, a dual lighting system is defined that addresses the need to light the highest point on an obstruction in circumstances where the upper part of the structure is not suitable for the attachment of high-intensity light units. This problem is overcome by the use of medium-intensity lighting at that location. At night, as shown in Annex 14, Volume I, Appendix 6, Figure 6.7, the lighting pattern consists of a combination of fixed- and flashing-red lights; no white lights are used in this layout. The lighting shown in Annex 14, Volume I, Appendix 6, Figure 6.8, is similar to that in Figure 6.7, but at night all units are medium-intensity fixed-red lights. The layout shown in Annex 14, Volume I, Appendix 6, Figure 6.8, is of particular use where environmental issues are a major consideration.

14.6 INSTALLATION OF HIGH-INTENSITY OBSTACLE LIGHTING

14.6.1 High-intensity white obstacle lights are used to indicate the presence of tall structures if their height above the level of the surrounding ground exceeds 150 m, and an aeronautical study indicates such lights to be essential for the recognition of the structure by day. Examples of such tall structures are radio and television antenna towers, chimneys and cooling towers (see Figures 14-2 and 14-3). When marking these structures, all lights are flashed simultaneously. High-intensity obstacle lights are also used on the support structures of overhead transmission lines (see Figure 14-4). In this use, the lights are flashed in a specific, vertical, coded sequence which is used not only to identify both the towers and the presence of transmission lines but also to advise pilots that they are approaching a complex obstacle, not an isolated one.

14.6.2 The peak intensity of the light beams should be capable of angular adjustment over the range zero to eight degrees above the horizontal. Normally lights should be installed with the beam peak at zero degrees elevation. Where terrain, nearby residential areas or other situations dictate, it may be beneficial to elevate the light beams of the lower units one or two degrees above the horizontal. The beam of light produced by units at the lower levels should not reach the ground closer than 4.8 km from the structure in order to prevent annoyance to local residents.

14.6.3 A relatively narrow vertical beam spread is required to provide full light intensity at possible collision altitudes with the obstacle. As little light as possible should be visible at altitudes greater than the height of the obstacle and on the ground.

14.6.4 High-intensity flashing-white obstacle lights on tall structures should have an effective intensity of not less than 200 000 cd. The intensity of the lights should decrease automatically to 20 000 cd at twilight and 2 000 cd at night-time through the use of photocells.

14.6.5 In the case of a guyed tower or antenna where it is not possible to locate a high-intensity light on the top, a light should be placed at the highest practical point and a medium-intensity obstacle light mounted on the top. Any medium-intensity flashing light should flash in unison with the high-intensity lights installed on the structure. During the day, the medium-intensity white light identifies the top of the structure once the pilot has made visual contact with the high-intensity lighting.

14.6.6 Structures supporting overhead electrical power transmission lines require a unique, vertical, sequen-

tially flashing system to provide adequate warning to pilots of the presence of both the towers and the wires between the towers. Marking systems consisting of paint and medium-intensity red lights do not provide any indication of the presence of transmission lines. A high-intensity lighting system is therefore recommended for this application. Synchronized flashing of the lighting systems on the supporting structures is also recommended.

14.6.7 High-intensity obstacle lights on towers supporting overhead wires should have a daytime intensity of not less than 100 000 cd. The intensity of the lights should decrease to 20 000 cd at twilight and 2 000 cd at night through the use of a photocell control.

14.6.8 Regardless of their height, the structures supporting overhead wires must be marked at three levels. The highest light level should be at the top of the support structure. The actual mounting height may be chosen to provide safe service access to the light. The lowest level should be at the level of the lowest point in the catenary between the two support structures. If the base of the support structure is higher than the lowest point of the catenary, the lowest level should be installed on the adjacent terrain in a manner that ensures unobstructed viewing. The middle level should be the midpoint between the top and bottom levels (see Figure 14-4).

14.6.9 The number of lights needed per level depends on the outside diameter of the structure being lit. The recommended numbers to obtain proper coverage are as follows:

<i>Diameter</i>	<i>Light units per level</i>
6 m or less	3
6 m to 30 m	4
30 m to 60 m	6
more than 60 m	8

14.6.10 The middle level should flash first, the top level flash second and the bottom level flash last. The interval between the flashing of the top level and the bottom level should be approximately twice the interval between the middle level and the top level. The interval between the end of one sequence and the beginning of the next should be about ten times the interval between the middle level and the top level.

14.6.11 Two or more light units should be installed at each light level and directed on a horizontal plane such as to provide 180 degrees of coverage centred on the transmission line. Where a catenary crossing is situated near a



Figure 14-2. High-intensity obstacle lights installed on a chimney

bend in a river, etc., the lights should be directed to provide the most effective light coverage to warn pilots approaching from either direction of the presence of the transmission lines.

14.6.12 High-intensity obstacle lights require a power input of approximately 200 W per light. Wire size on the structure should be based on 400 V/A average input per light. If transformers must be used, they should be designed to 600 V/A in order to prevent core saturation during peak current demands. High-intensity obstacle lights are usually operated at 240 V or 480 V to minimize wire and conduit size, but voltages as low as 120 V can be used. Both 50 Hz and 60 Hz systems are available.

14.6.13 High-tension overhead wires present a significant hazard to low-flying aircraft. The span of the wires is often very long. At some locations high-tension

wires cross a valley or river without intermediate supports. This makes lighting of the masts with low- and medium- intensity lights ineffective. In this case, installation of the lights on the wires themselves should be considered.

14.6.14 There are significant difficulties in mounting low-intensity obstacle lights on wires. If the voltage of the current is considerable, it is extremely difficult to use it directly to energize conventional lamps because of the insulation and current transformation problems that arise. The cost of providing a low-tension power source (110 V or 220 V) to energize such lamps can be considerable. The device described below has been specifically developed with a view to resolving these difficulties and to facilitate the installation of obstacle lights complying with the specifications given in Annex 14, Volume I, Chapter 6, 6.3. The system comprises:

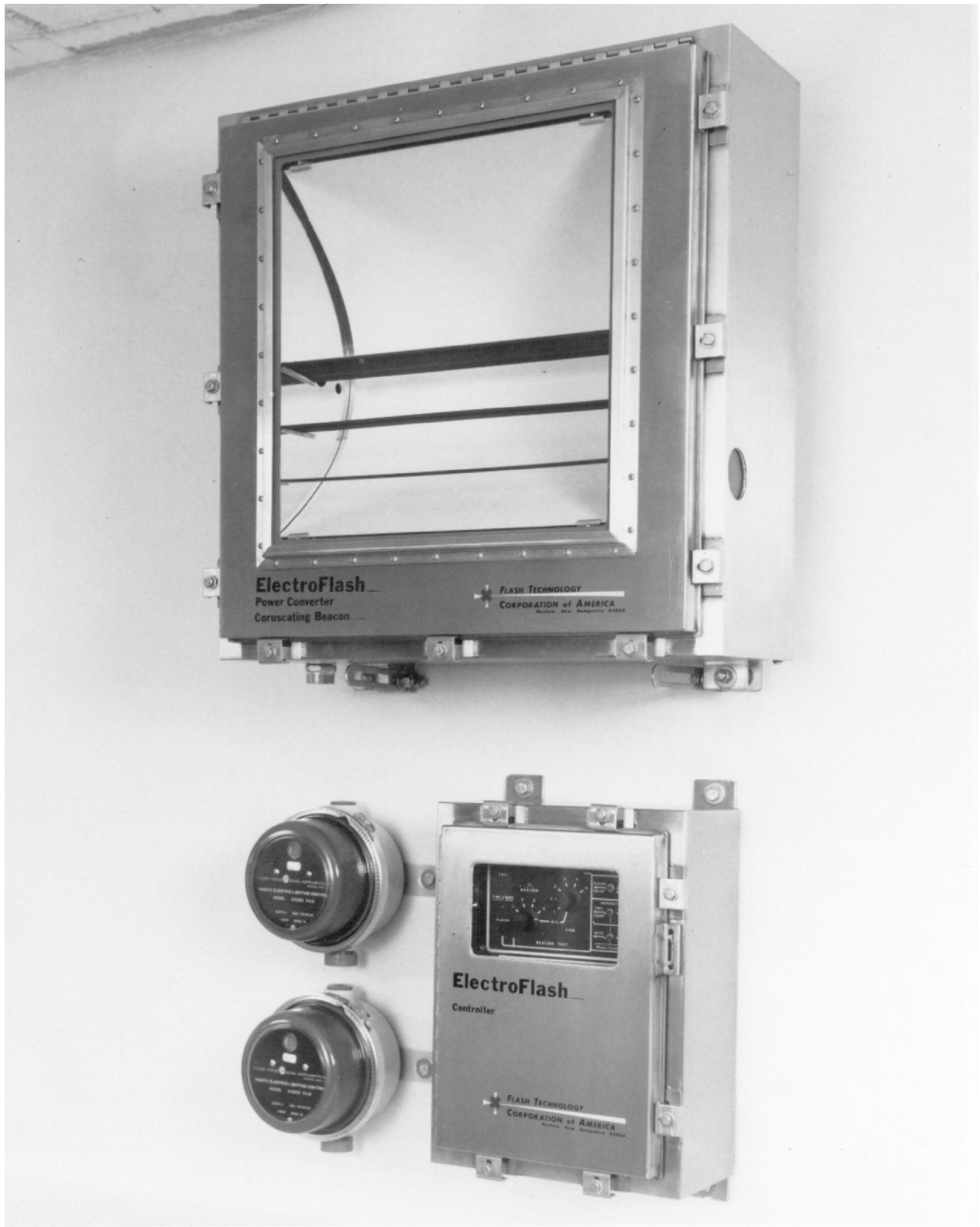

Figure 14-3. A typical high-intensity obstacle light unit

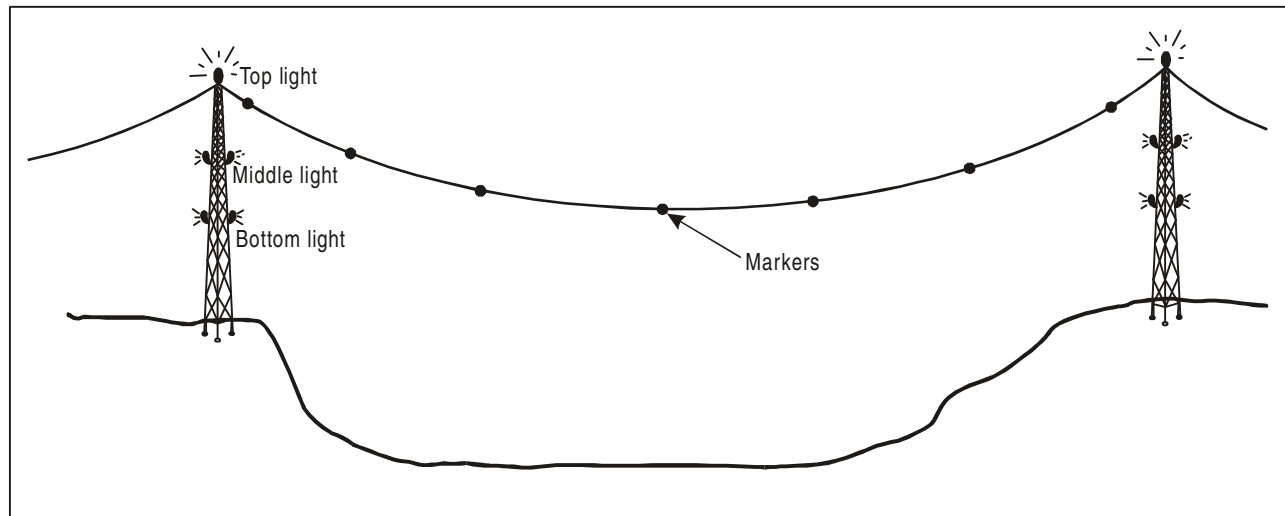

Figure 14-4. Location of high-intensity obstacle lights on towers supporting overhead wires

- a) a light source; and
- b) an auxiliary conductor to convey the necessary electrical energy.

14.6.15 The light source consists of a discharge lamp in a low-pressure neon gas atmosphere that produces red light. The lamp has a lifetime of several tens of thousands of hours. The principle of energy derivation involves an electrical source with low current and high tension; the lamp consists of a long small diameter glass tube with heli-coidal winding and two cold electrodes. The unit is housed in a protective sleeve of toughened glass with a diameter of approximately 50 mm. The ends of the protecting tube are hermetically sealed with metallic stoppers so that the internal space can be filled with a special liquid to eliminate radio parasitic emissions. The lamp itself is hung on flexible mountings, with one side to the active line and the other side to the auxiliary conductor.

14.6.16 The auxiliary conductor is a section of metallic conducting wire insulated from the main wire and intended to produce, by a capacitive effect, the electrical energy necessary to operate the lamp. The geometry of the auxiliary conductor depends on the active line and its voltage. The conductor consists of tubes 4 m long made of high-grade aluminium; the number and configuration are determined by the conditions of operation. The length of the auxiliary wire is inversely proportional to the voltage of

the main wire. The auxiliary conductor is suspended by glass insulators of high mechanical strength and aluminium jaws to avoid any problem of electrical coupling with the cables. The jaws are fitted for the exact diameter of the electrical cables. The diameter range available is 16 mm to 34 mm; the operating voltage of this lamp is several thousand volts.

14.6.17 The system is shown in Figure 14-5. For different voltages there are two configurations to respond to the need for simplicity of assembly and to avoid causing additional disturbances in the radio frequencies other than those naturally emitted by high-tension cables. In this way the objective of lighting the high-tension cables themselves with low-intensity lights can be safely achieved.

14.7 MONITORING AND MAINTENANCE

14.17.1 High-intensity obstacle lights should be monitored continuously through the use of an automatic monitoring system or be checked visually once every 24 hours.

14.17.2 All components in discharge lighting equipment, including the light source, should be designed for ease of maintenance and to provide the specified performance for a period of at least one year without maintenance.

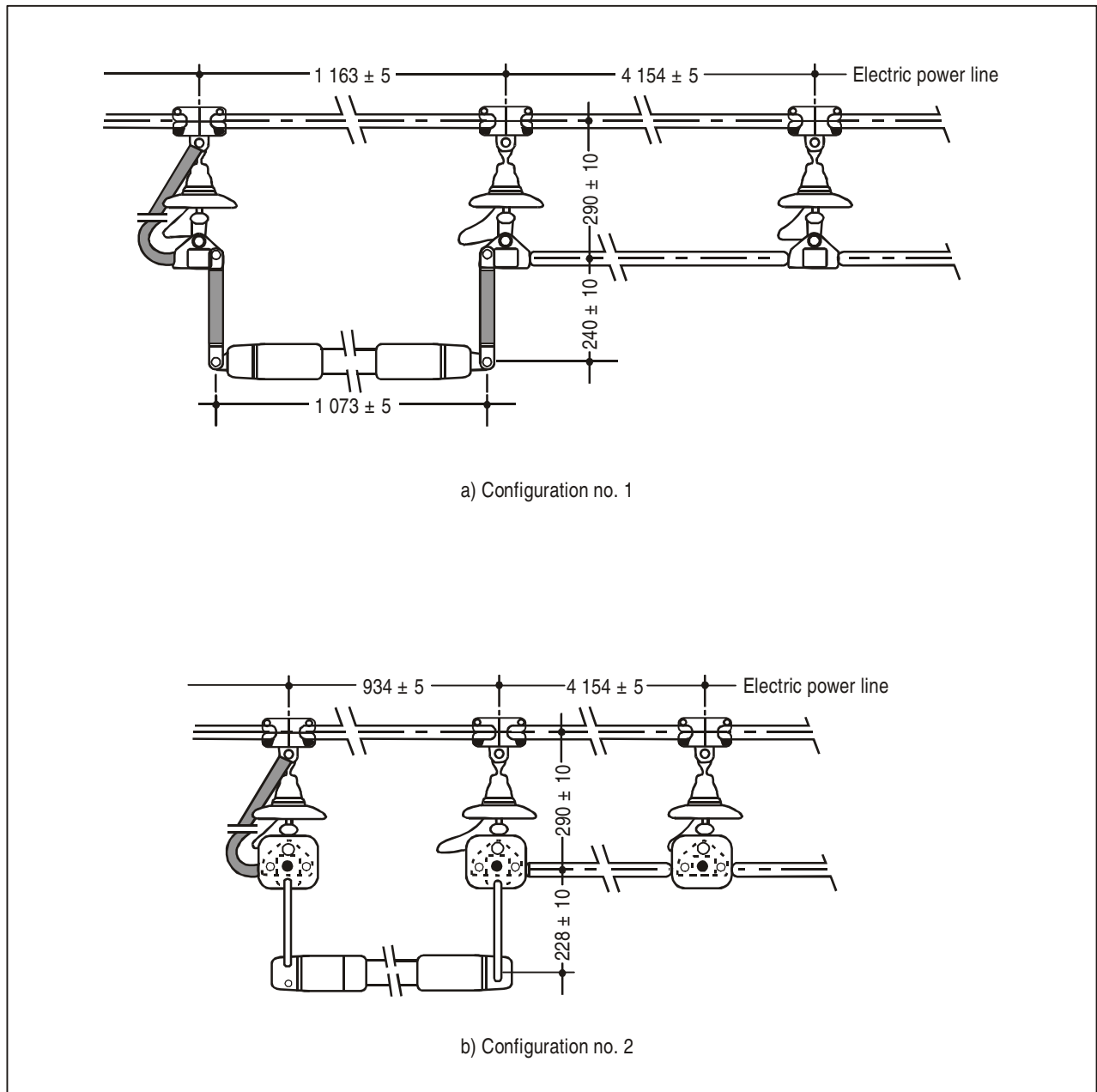

Figure 14-5. Installation of obstacle lights on high-tension wires

Chapter 15

Frangibility of Visual Aids

15.1 WHAT IS FRANGIBILITY?

15.1.1 A frangible object is defined as an object of low mass designed to break, distort or yield on impact so as to present the minimum hazard to aircraft.

15.1.2 At airports, various visual and non-visual aids for navigation are located near runways, taxiways and aprons, where they may present a hazard to aircraft in the event of accidental impact during landing, take-off or ground manoeuvring. All such equipment and their supports shall be frangible and mounted as low as possible to ensure that impact will not result in loss of control of the aircraft. This frangibility is achieved by using lightweight materials and break-away or failure mechanisms which will enable the object to break, distort or yield under impact.

15.2 OBSTACLES TO BE MADE FRANGIBLE

15.2.1 All fixed objects, or parts thereof, that are located on an area intended for the surface movement of aircraft or that extend above a surface intended to protect an aircraft in flight are, by definition, obstacles. The first objective should be to site objects so that they are not obstacles. Nevertheless, certain airport equipment and installations, because of their function, must inevitably be located so that they are obstacles. All such equipment and installations as well as their supports shall be of minimum mass and frangible in order to ensure that impact will not result in loss of control of the aircraft.

15.2.2 Annex 14, Volume I, Chapter 8, specifies, as a Standard, that the following areas must be maintained free of all but frangible equipment and installations required for air navigation:

- a) that portion of the runway strip within:
 - 1) 75 m of the runway centre line where the code number is 3 or 4; or

- 2) 45 m of the runway centre line where the code number is 1 or 2;
- b) runway end safety area;
- c) clearway;
- d) taxiway strip (or within the distances specified in Annex 14, Volume I, Table 3-1, column 11); and
- e) the area within 240 m of the end of the strip and within:
 - 1) 60 m of the extended centre line where the code number is 3 or 4; or
 - 2) 45 m of the extended centre line where the code number is 1 or 2

of a precision approach runway Category I, II or III.

15.2.3 Annex 14, Volume I, Chapter 8, further recommends that any equipment or installation required for air navigation purposes which must be located in the non-graded portion of a runway strip should be regarded as an obstacle and should be frangible and mounted as low as possible.

15.2.4 In addition to the areas detailed above, air navigation equipment or installations that project above one of the obstacle limitation surfaces specified in Annex 14, Volume I, Chapter 4, should also be frangible.

15.2.5 Guidance on the frangible design of visual and non-visual aids for navigation, including design criteria, testing procedures and acceptance criteria, is given in the *Aerodrome Design Manual*, Part 6 — *Frangibility**.

* In preparation.

15.3 VISUAL AIDS

General

15.3.1 Visual aids which, because of their particular air navigation function, will have to be located in one of the areas identified above or, alternatively, so that they penetrate one of the obstacle limitation surfaces, include elevated runway, taxiway and stopway lights; approach lighting systems; visual approach slope indicator systems and signs and markers.

Elevated runway edge, threshold, end, stopway and taxiway edge lighting

15.3.2 The height of these lights should be sufficiently low to ensure propeller and engine pod clearance. Wing flex and strut compression under dynamic loads can bring the engine pods of some aircraft to near ground level. Only a small height can be tolerated and a maximum height of 36 cm is advocated.

15.3.3 These aids should be mounted on frangible mounting devices. The desirable maximum height of light units and frangible coupling is as indicated above. Units exceeding this height limitation may require higher breaking characteristics for the frangible mounting device, but the frangibility should be such that, should a unit be hit by an aircraft, the impact would result in minimum damage to the aircraft.

15.3.4 In addition, all elevated lights installed on runways where the code number is 3 or 4 should be capable of withstanding a jet engine exhaust velocity of 300 kt; lights on runways where the code number is 1 or 2 should be capable of withstanding a lower velocity of 200 kt. Elevated taxiway edge lights should be able to withstand an exhaust velocity of 200 kt.

Approach lighting system

15.3.5 Guidance on the frangibility of approach lights is more difficult to develop because there is a greater variation in their installation. Conditions surrounding installations close to the threshold are different from those near the beginning of the system; for example, lights within 90 m of the threshold or runway end are required to withstand a 200-kt blast effect, whereas lights further out only need to withstand a 100-kt blast or the natural environmental wind load. Also the terrain close to the threshold

can be expected to be near the same elevation as the threshold, thus permitting the lights to be mounted on short structures. Farther from the threshold, support structures of considerable height may be required.

15.3.6 Annex 14, Volume I, specifies, as a Standard, that elevated approach lights and their supporting structures shall be frangible except that, in that portion of the approach lighting system beyond 300 m from the threshold:

- a) where the height of a supporting structure exceeds 12 m, the frangibility requirement shall apply to the top 12 m only; and
- b) where a supporting structure is surrounded by non-frangible objects, only that part of the structure that extends above the surrounding objects shall be frangible.

15.3.7 Elevated approach lights and their supporting structures shall be designed to withstand the static and operational/survival wind loads with a suitable factor of safety, but break, distort or yield readily when subjected to the sudden collision forces of a 3 000-kg aircraft airborne and travelling at 140 km/h (75 kt). The structure shall not wrap around the aircraft but shall crumple or collapse on impact.

15.3.8 The frangibility of the design should be proven either by means of full-scale tests or by computer evaluation using an appropriate software code for structural analysis.

15.3.9 Where it is necessary for approach lights to be installed in stopways, the lights should be inset in the surface if the stopway is paved; if the stopway is not paved, they should be either inset or elevated (in which case they should meet the criteria for frangibility agreed for lights installed beyond the runway end).

Other aids

15.3.10 These aids, for example, PAPI, T-VASIS, signs and markers, should be of low mass and located as far as practicable from the edges of runways, taxiways and aprons as is compatible with their function. Every effort should be made to ensure that the aids will retain their structural integrity when subjected to the most severe environmental conditions. However, when subjected to aircraft impact in excess of the foregoing conditions, the aids will break or distort in a manner which will cause minimum or no damage to the aircraft.

15.3.11 When installing visual aids in the movement area, caution should be taken to ensure that the light support base does not protrude above ground but rather terminates below ground as required by environmental conditions so as to cause minimum or no damage to the aircraft overrunning them. However, the break-away mechanism should always be above ground level.

Chapter 16

Application of Approach and Runway Lighting Systems

16.1 GENERAL

16.1.1 Many of the Standards and Recommended Practices for approach and runway lighting in Annex 14, Volume I, Chapter 5, have been developed to support the safe and regular operation of aircraft landing in all weather conditions. It is on the basis of the provision of these lighting systems that the operational requirements for aircraft take-off and landing cues are defined.

16.1.2 During the 1940s and 1950s, the design principles for the approach and runway lighting patterns in use today were developed through research and a programme of progressive in-service development and evaluation. The main principle behind the design of the lighting systems is that they should enable pilots operating at night or in any low visibility conditions to control their aircraft in the same manner as they would in clear weather conditions by day.

16.2 LIGHTING SYSTEM DESIGN

16.2.1 The information displayed to pilots by the approach and runway lighting is in the form of standardized, easily recognizable patterns of lights. Colour is used in some elements of the system to reinforce the information, but the main design goal is to present the pilot with patterns that can be instinctively interpreted.

16.2.2 The coverage and the sensitivity of the cues provided are carefully matched to the operations that the lighting is designed to support.

16.2.3 The beam characteristics of the lights within each pattern are therefore a key design parameter. High intensities are provided to support daytime operations in low visibility conditions. In all other circumstances, medium- or low-intensity lighting meets the operational requirement. In practice, the lighting specified for a given

runway should be compatible with the most demanding operation normally conducted at that runway. Before installing high-intensity lighting, the designer and aerodrome operator should ascertain that such a level is necessary. For example, night VFR operations only require low- or medium-intensity lighting. As regards approach lighting, this can often be provided using the abbreviated pattern options specified in Annex 14, Volume I, Chapter 5, the simple approach lighting system.

16.2.4 High-intensity lighting requires the provision of a multi-stage brilliancy control to enable the light output to be constantly matched to the prevailing operational conditions (see Chapter 5). The use of inappropriately high intensities will cause glare problems. If it can be shown that only low-intensity lighting is required to support all the operations planned for a particular runway, the cost-benefits in terms of simplified control gear, types of light fittings used and overall power consumption should always be carefully considered. This should be done at the design stage of any approach and runway lighting installation.

16.2.5 Approach and runway lighting of increasing complexity is specified to support non-instrument, non-precision operations as well as Category I, Category II and Category III precision landing operations. The outer portions of the high-intensity approach lighting systems are only essential operationally for Category I approaches. In this type of operation, the aircraft is at a distance of 900 m or greater from the threshold at the decision height (DH). In these circumstances, the distance ahead of the aircraft to the furthest light that can be seen is generally small. In the visibility conditions associated with non-instrument and non-precision approaches, a short length of approach lighting is sufficient. Initial contact with the approach lighting is normally made in these circumstances after the aircraft has descended below the height of the prevailing cloud base. The lighting is seen by the pilot at a significant distance ahead of the aircraft, rather than just beyond the cockpit cut-off as is the case in low visibility conditions. In

this type of operation, the approach lighting is an important aid to the pilot in establishing the location and relative orientation of the runway and approach centre line and in supporting any subsequent corrective manoeuvres that are required to the aircraft flight path.

16.2.6 For take-off operations, the lighting that is installed on the runway may need to have greater capability than would be indicated from consideration of the approach categorization alone. For example, a runway that does not have a non-visual guidance aid capability and, hence, may only be equipped with a simple approach lighting system will still require runway lighting that meets the high specifications if, as is feasible, take-off operations are to take place from that runway in low RVR conditions.

16.3 LIGHTING FOR NON-INSTRUMENT AND NON-PRECISION APPROACH RUNWAYS

Simple approach lighting systems

16.3.1 The specifications for this system are in Annex 14, Volume I, Chapter 5, 5.3.4 and Attachment A, Figure A-5. The pattern consists of a 420-m-long centre line located on the extended runway centre line and a crossbar to provide roll references at a distance of 300 m from the threshold. The pattern is designed to support non-precision approaches, although it is advised that consideration should be given to the installation of precision approach Category I lighting systems for this type of operation if it is desired to enhance the guidance and make the task of the pilot easier.

16.3.2 It is recognized that it may be justified in some locations to reduce the length of the simple approach lighting system to a length that is practicable. For example, this action may be necessary where the terrain in the final approach area falls away steeply prior to the runway threshold. Annex 14, Volume I, Chapter 5, 5.3.4.5, describes the options in detail.

16.3.3 There are also some circumstances where it is not practicable to install any approach lighting. In these circumstances, non-precision operations will be limited by day and by night to good visibility conditions. Operations will only be conducted if it can be shown that in these circumstances sufficient guidance is available from runway edge, threshold and end lights or other visual aids.

16.3.4 It is recommended that a simple approach lighting system should also be installed where practicable

to support non-instrument operations at night in good visibility conditions if the code number is 3 or 4.

16.3.5 If additional conspicuity is required to aid the pilot in the task of locating and aligning with the runway or if it is not practicable to install any approach lighting, flashing runway threshold identification lights may be provided (see Annex 14, Volume I, Chapter 5, 5.3.8).

Runway lighting

16.3.6 Runway edge lighting and the associated runway threshold and runway end lights should be provided if it is intended that the runway be used for night operations. The most practicable means of meeting all the requirements, including that of ensuring the visibility of the lights at all angles of azimuth to aid circling approaches, will be the use of low-intensity omnidirectional lighting.

16.4 LIGHTING FOR PRECISION APPROACH RUNWAYS — CATEGORY I, II AND III

High-intensity approach lighting

16.4.1 The specifications for this lighting are in Annex 14, Volume I, Chapter 5, 5.3.4.10 to 5.3.4.39 and Attachment A, Figure A-6. The appropriate paragraphs describe how the basic system is to be installed to support Category I precision approaches. The 900 m length of the system provides the necessary alignment and roll cues in the lowest Category I conditions of 200 ft decision height and an RVR of 550 m.

16.4.2 The alternative patterns shown in Annex 14, Volume I, Attachment A, Figure A-6, both provide the cues required for Category I operations. System A specifically includes distance-from-threshold coding in the pattern and provides particularly strong roll cues that can be beneficial in the event of an aircraft being delivered by the non-visual approach system at or near the permitted deviation boundaries for this type of approach. System B may in some cases be more practicable to install due to the shorter length of the crossbar elements of the system. This pattern is recommended to be augmented by sequenced flashing lights to enhance the conspicuity of the centre line, as shown in Attachment A, Figure A-6.

16.4.3 Sequenced flashing lights are found to be particularly beneficial when the lighting is being used in medium or good visibility conditions since, in these

circumstances, the character of the signal enhances the conspicuity of the approach lighting pattern. This feature is particularly evident in daytime conditions where the meteorological visibility results in a low contrast view of the ground with few objects or other features visible. At night, the flashing lights can be of particular benefit in locating the position of the runway in a visually cluttered urban environment where many non-aviation lights are visible to the pilot.

16.4.4 The isocandela specification in Annex 14, Volume I, Appendix 2, Figure 2.1, is used for all the steady burning lights in the high-intensity approach lighting system. The elevation setting angles should always be in accordance with the table given in the figure. These angles vary from 5.5 degrees near the runway threshold to 8 degrees in the outermost parts of the pattern. These angles must be maintained at all times because they are an essential part of the optimized design of the lighting system. They ensure that the segment of lighting seen by the pilot is as large and as consistent as possible in all prevailing conditions. Misalignments as small as 1 degree can be detected, and larger misalignments can result in an incomplete pattern being seen in low visibility conditions.

Supplementary high-intensity approach lighting

16.4.5 Where the approach lighting is provided to support Category II and III operations, the basic patterns are supplemented by additional lights located in the area between the runway threshold and the 300 m approach lighting crossbar.

16.4.6 The practical effect of these additional requirements is that the lighting in the 300 m prior to the threshold is the same whichever of the two patterns (System A or B) is used. The centre line in this inner section of the approach lighting consists of white barrettes. Red barrettes are installed on either side of this centre line pattern.

16.4.7 The pattern of supplementary red barrettes provides two important cues. The lateral position of the barrettes indicates the boundaries of the offset permissible for a Category II approach to be continued to a landing. The second cue is derived from the longitudinal position of the red barrettes. Sighting the red barrettes indicates to the pilot that the aircraft is 300 m or less from the runway. Both of these cues are important, particularly in support of the decision-making process associated with a Category II approach and landing operation, because the time available to make an assessment of the aircraft's position is short once visual contact with the lighting has been made.

16.4.8 It should be noted that for the System B lighting pattern used in Category II and III conditions, flashing lights are not installed in the inner 300 m of the centre line pattern. This omission ensures that the inner 300 m of the System A and B patterns, designated to support Category II and III operations, are identical.

High-intensity runway lighting

16.4.9 The specifications for high-intensity runway lighting are given in Annex 14, Volume I, Chapter 5, 5.3.9 to 5.3.11 and Appendix 2, Figures 2.3, 2.4 and 2.8 to 2.10. It consists of three systems, i.e. runway edge lighting, runway threshold and wing bar lighting and runway end lighting. As with the runway lighting associated with non-instrument and non-precision approaches, the basis of the high-intensity runway lighting is patterns of lights defining the limits of the runway. The edges show white light, the threshold green and the stop end red. The high intensities specified are necessary to provide the pilot with a sufficient view of the runway dimensions during the final approach, flare and ground roll. The maintenance of the correct beam and setting angles is crucial to the proper functioning of the system.

16.4.10 The intensity of the runway threshold and runway end lights should match that of the runway edge lights. Light attenuation of approximately 80 per cent results from the use of filter material to produce the requisite colour for these lights. It is not, therefore, acceptable to use the same light fitting for the runway edge lights and the runway threshold and end lights. Light fittings specifically designed for application at the runway threshold and stop end are available and should always be used. Provision of the specified intensity is particularly important in low visibility conditions where, for instance, a clear recognition of the location of the green threshold lighting bar is a significant cue to pilots. It indicates that the aircraft has reached the runway on which it is intended to complete the landing.

Supplementary high-intensity runway lighting

16.4.11 Supplementary high-intensity runway lighting is specified for landing operations where the RVR is less than 550 m and take-off operations where the RVR is less than 400 m. The specifications are given in Annex 14, Volume I, Chapter 5, 5.3.12 and 5.3.13 and Appendix 2, Figures 2.5 to 2.7. It consists of two systems, i.e. runway centre line lighting and touchdown zone lighting.

16.4.12 The function of the centre line lighting is to provide the pilot with lateral guidance during the flare and landing ground roll or during a take-off. In normal circumstances, a pilot can maintain the track of the aircraft within approximately 1 to 2 m of the runway centre line with the aid of this lighting cue. The guidance information from the centre line is more sensitive than that provided from the runway edge lighting. In low visibility conditions, the use of the centre line is also the best means of providing an adequate segment of lighting for the pilot to use. The greater distances involved in viewing the runway edge lighting together with the need for the pilot to look immediately ahead of the aircraft during the ground roll also contribute to the requirements for a well-lit runway centre line.

16.4.13 The final 900 m of the runway centre line lighting is colour-coded to assist pilots in their assessment of the runway distance remaining during landing or during take-off.

16.4.14 The touchdown zone lighting consists of two areas of equi-spaced white barrettes on either side of the centre line. The lights are installed in the runway surface between the threshold and the position 900 m beyond the threshold. The lateral separation of the two areas of barrettes is the same as that for the supplementary red barrettes in the approach area.

16.4.15 The touchdown zone lighting provides a structured texture on the runway surface at a position where the pilot landing an aircraft needs to have strong cues to support the flare manoeuvre and to assess the track of the aircraft. The lighting provides these cues during the flare with a much greater sensitivity than is available from any other lighting on the runway. Furthermore, the cues are close to the field-of-view of the pilot. Sensitive height rate cues are derived from the pattern through the motion of the touchdown zone lighting patterns that is apparent to the pilot as the flare progresses. Cues having this sensitivity are not available from the motion of the runway edge lighting in the field-of-view.

16.5 PATTERN VARIATIONS AND ADDITIONS

16.5.1 There are some situations in which the runway lighting has to be augmented with additional patterns. For example, where a displaced threshold is in use, the lighting patterns are still configured to conform to the standards, but it is necessary to take additional measures to ensure that the

correct guidance is provided. Annex 14, Volume I, Figure 5-22, gives an example of such provisions.

16.5.2 In well-defined circumstances, such as a location where the installation of the full lighting pattern is impracticable, the overall length of the approach lighting system may be abbreviated, but this may impose operational limitations.

16.6 REDUCTION OF LIGHTING PATTERNS

16.6.1 Extensive operational experience with the lighting systems specified in Annex 14, Volume I, has shown that the cues provided by the lights and the operations conducted with them are well matched. Nevertheless, under specific circumstances, the Annex permits the reduction of the number of lights that define certain patterns within these lighting systems.

16.6.2 As the level of all-weather capabilities increases both within the airlines and at aerodromes in response to operational needs, a number of issues need to be kept under review. For example, with an increase in the percentage of landings that can be carried out automatically, there is a corresponding decrease in the essential use of approach lighting systems. The use of autopilot to control the aircraft until the final stages of the approach with the pilot completing the landing manually from a position where flight path errors are small also means less reliance on lighting to support significant manoeuvring of the aircraft at low heights.

16.6.3 Appendix 4 describes the procedures to be used for designing the lighting specified in Annex 14, Volume I, Chapter 5, as well as the availability of improved computer programmes for the design and assessment of lighting systems and lighting system performance that take account of greater knowledge of fog characteristics and how they affect the operational performance of lighting systems.

16.6.4 A radical redesign of aerodrome lighting systems is not practicable. What can be considered is to what extent the lighting specified can be reduced without adversely affecting the safety or regularity of operations. In the original design of lighting systems, considerable emphasis was placed on the reliability of the guidance. To ensure adequate levels of availability at all times, a high degree of redundancy was built into the lighting patterns so that a failure of complete lighting circuits hopefully would not hazard operations in any way. This over-provision of lighting to achieve reliability was compounded when

additional patterns of lights were added to the basic designs as operations in low visibilities became more commonplace. These trends have resulted in lighting systems that could potentially be simplified without any significant loss of guidance. Simulation trials have clearly demonstrated that the number of lights in the lighting patterns can be considerably reduced without adversely affecting operational performance.

16.6.5 It can be seen from Annex. 14, Volume I, Chapter 5, that in some clearly specified circumstances, where there has been a demonstrable achievement of specific maintenance objectives, it would be acceptable to reduce the number of lights that define certain patterns within lighting systems. The level of serviceability to be met before the number of lights can be reduced is specified in Annex 14, Volume I, Chapter 9.

16.6.6 The achievement of the specified maintenance objectives should be demonstrated through appropriate monitoring and the keeping of records on lighting performance. Further guidance on this subject is contained in Chapter 17.

16.6.7 Where maintenance standards support such a reduction it is permissible:

- a) for a precision approach Category I lighting system, to reduce the number of lights in the approach centre line so that each light position consists either of a single light source or, where barrettes are used, of four lights defining each barrette;
- b) for a precision approach Category II or III lighting system, to reduce the number of lights in the approach centre line in the innermost 300 m of the centre line so that alternate light points consist of either a single light or a barrette of four lights. Alternatively, a four-light barrette may be used at each light position;

- c) to use 60 m longitudinal spacing for side row barrettes; and
- d) to use a runway centre line light spacing of 30 m for operations in RVR down to 350 m.

16.6.8 For a 3 000-m-long runway, these reduced provisions will delete approximately 120 lights from the approach and runway lighting systems. The differences between the two patterns are illustrated in Figures 16-1 and 16-2.

16.7 SELECTION OF LIGHTING PATTERNS

16.7.1 The most demanding operational scenario will determine the required level of approach and runway lighting to be provided by an aerodrome operator. For example, a runway which is to be used only for non-instrument or non-precision approaches will be adequately served by the simpler lighting systems specified in Annex 14, Volume I. In these circumstances, it is unnecessary to provide high-intensity lighting systems.

16.7.2 Where the specification of high-intensity lighting systems is clearly justified on operational grounds, the option to use reduced lighting patterns should be carefully considered. Use of these patterns is dependent upon the provision of adequate levels of performance in terms of light output and the reliability of the electrical systems. However, since the specifications are written on the assumption that such levels will be achieved in service, it should be possible to take advantage of the more relaxed provisions for any new installation.

16.7.3 Whenever the provision of approach and runway lighting is being considered, the need to provide visual glide slope information should also be taken into account, since this type of aid is the only means of providing adequate visual guidance in the vertical plane.

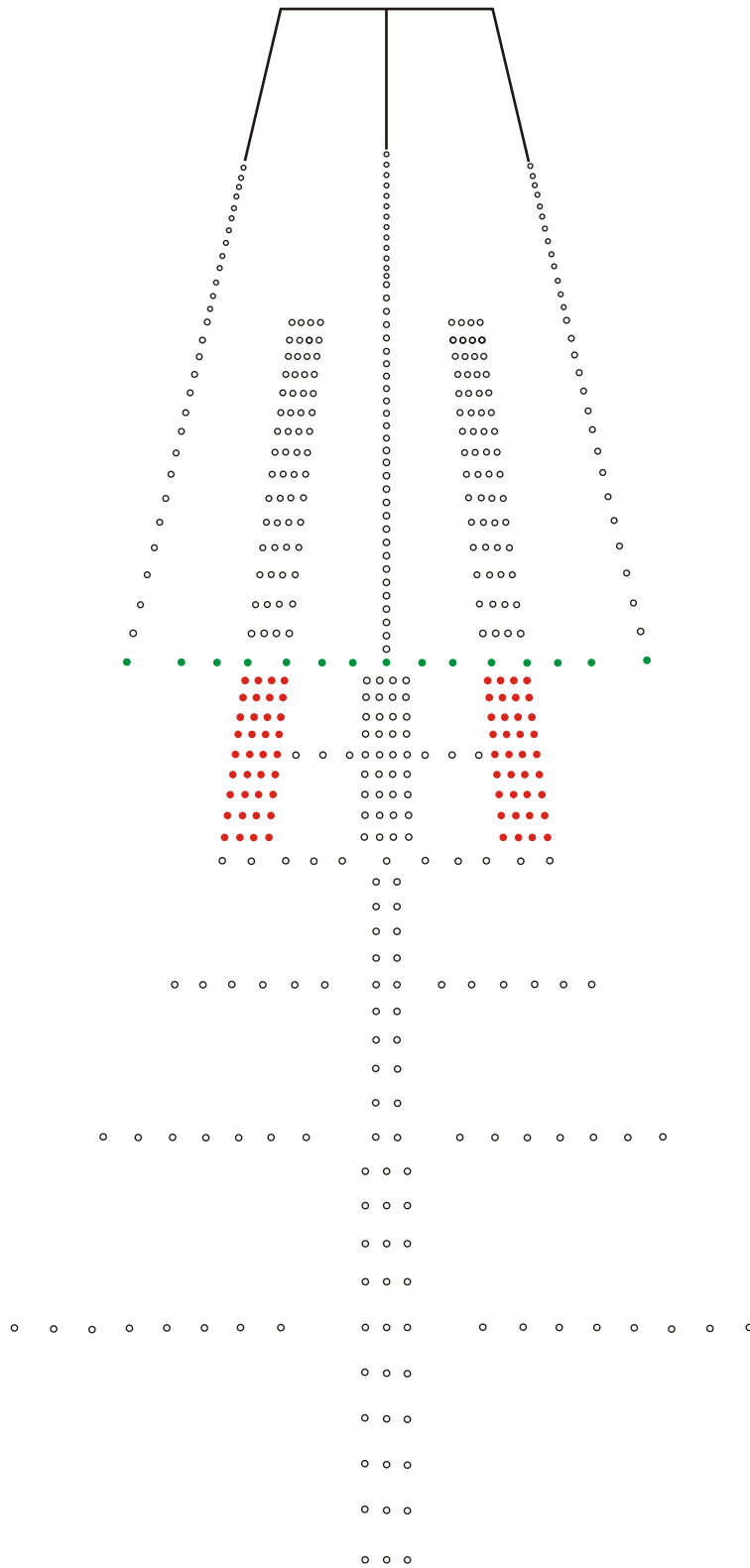

Figure 16-1. Approach and runway lighting, full pattern

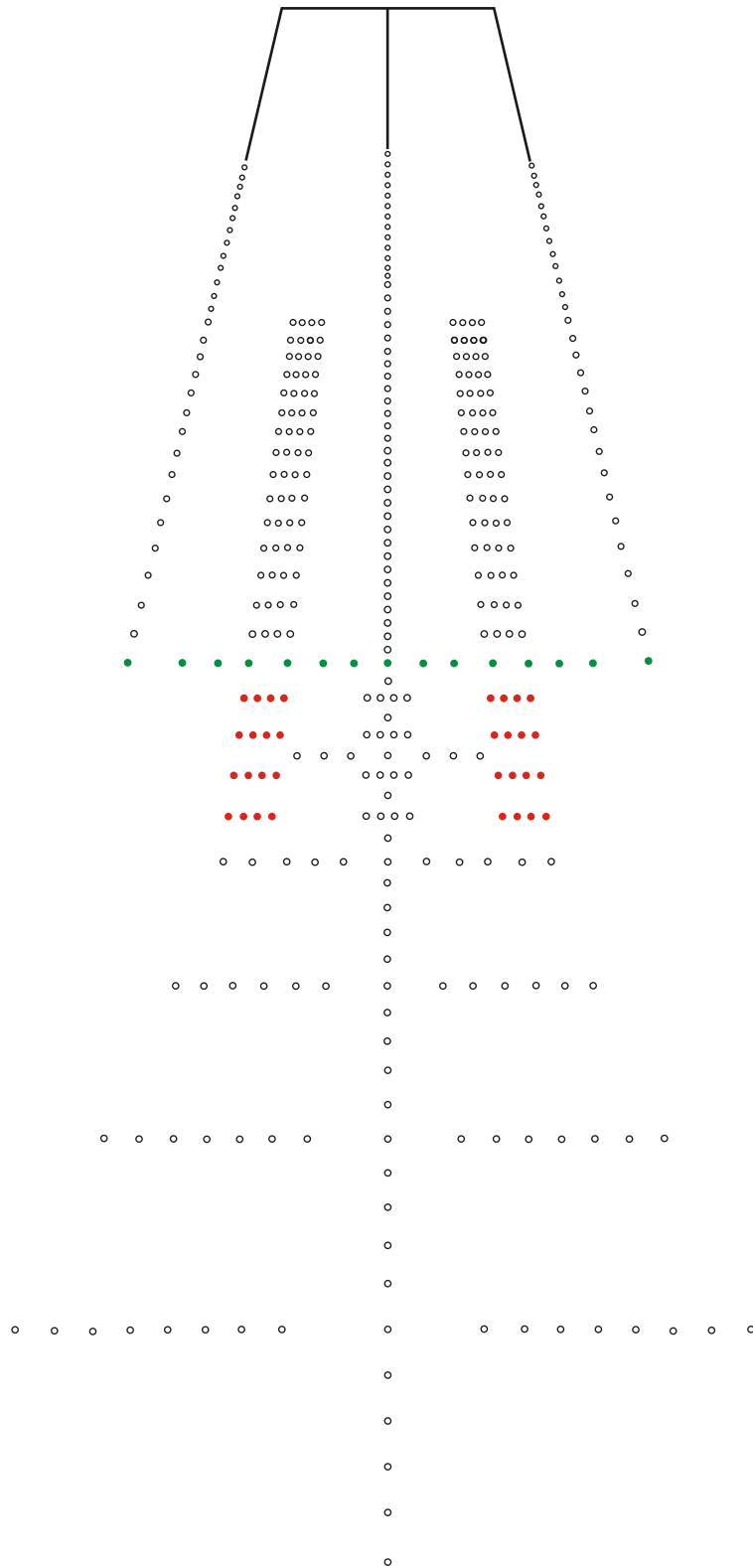

Figure 16-2. Approach and runway lighting, reduced pattern

Chapter 17

Maintenance of Lighting Performance

17.1 GENERAL

17.1.1 The lighting systems specified in Annex 14, Volume I, Chapter 5, are designed to provide the visual aids that pilots need to operate their aircraft safely and efficiently in all weather conditions by day and by night. To be effective, the characteristics of each aid must be maintained at all times. This objective can only be achieved through the development and application of appropriate maintenance procedures. The environment within which the equipment is required to function is such that maintenance procedures used for other types of lighting equipment are often inadequate.

17.1.2 The purpose of this chapter is to provide guidance on the specifications in Annex 14, Volume I, Chapter 9, 9.4, on the system of preventive maintenance to be employed for approach and runway lighting systems intended to support operations in Category II and III conditions.

17.1.3 A review of the maintenance practices for visual aids and electrical systems required at an airport is contained in the *Airport Services Manual*, Part 9 — *Airport Maintenance Practices* (Doc 9137).

17.2 THE MAINTENANCE ENVIRONMENT

17.2.1 Lighting equipment on an aerodrome is subjected to a wide range of temperatures, high-velocity engine efflux, contaminants such as aviation fuel, oil and de-icing fluids and rubber deposits from aircraft tires. The lighting is also subjected to mechanical shock caused by aircraft landing and manoeuvring on the airport.

17.2.2 The performance of light fittings can change significantly over a short period of time, especially at large aerodromes with high movement rates. For example, it has been shown that a single application of anti-icing fluid to a runway can reduce the light output of centre line light fittings by up to 70 per cent.

17.3 MAINTENANCE REQUIREMENTS

17.3.1 All lighting aids used on aerodromes are specified using parameters that should ensure that pilots can see and identify the visual cues that are provided over a range of defined operational conditions. For each type of aid, the extreme positions from which the light must be seen are clearly defined in terms of viewing angles and detection range required in the lowest visibility conditions in which operations are to take place.

17.3.2 From a knowledge of the operational requirements, an isocandela diagram and the associated aiming parameters are computed and standardized for each lighting system. Where colour is part of a system, this is also specified.

17.3.3 Operational criteria for aircraft are developed on the assumption that the lighting aids will be functioning in accordance with the published specifications. Any shortfall in performance will adversely affect the ability of a pilot to acquire the required cues. This may result in overshoots or create difficulties during ground movements. In low visibility conditions, a reduction in light output of 50 per cent reduces the range of the lighting aid by approximately 10 per cent. Such a reduction in range can be critical and may result in the pilot not seeing the necessary cues. Furthermore, especially for in-pavement light fittings, reductions in light output well in excess of 50 per cent will frequently occur unless a good maintenance regime is in operation. The reductions in light output are mainly due to contamination by dust, rubber deposits and de-icing fluids, misalignment of the optics within the light fitting and misalignment of the fitting.

17.3.4 In practice the most demanding situations occur in low visibility conditions by day. These conditions define the performance requirements, and in order to meet these circumstances it is essential that lighting performance is maintained at the specified values.

17.3.5 The requirements of Annex 14, Volume I, Chapter 8, clearly indicate that, to achieve the high levels

of reliability necessary for the visual aids to properly support operations, attention must be given to the design, operation and monitoring of the electrical supplies. Strict limits are set on the levels of availability of the various aids. Reliable indications of the levels of serviceability should be an integral part of any system design.

17.3.6 The requirements of Annex 14, Volume I, Chapter 8, also indicate that a system of monitoring visual aids should be employed to ensure lighting system reliability.

17.3.7 Annex 14, Volume I, Chapter 9, specifies, as a Standard, that a system of preventive maintenance of visual aids shall be employed to ensure lighting and marking system reliability. Maintenance of visual aids is further addressed in a series of requirements that define the performance level objectives. Defining the minimum serviceability level below which operations should not continue is the responsibility of the relevant regulatory authority.

17.3.8 Furthermore, Annex 14, Volume I, Chapter 9, recommends that the system of preventive maintenance to be employed for a precision approach runway Category II and III should include at least the following checks:

- a) visual inspection and in-field measurement of the intensity, beam spread and orientation of lights included in the approach and runway lighting systems;
- b) control and measurement of the electrical characteristics of each circuitry included in the approach and runway lighting systems; and
- c) control of the correct functioning of light intensity settings used by air traffic control.

17.3.9 Annex 14, Volume I, Chapter 9, also recommends that for lights included in approach and runway lighting systems for a precision approach runway Category II and III:

- a) the in-field measurement of intensity, beam spread and orientation of lights should be undertaken by measuring all lights, as far as practicable, to ensure conformance with the applicable specification of Annex 14, Volume I; and
- b) the measurement of intensity, beam spread and orientation of lights should be undertaken using mobile measuring equipment of sufficient accuracy to analyse the characteristics of the individual lights.

17.4 MONITORING OF LIGHT OUTPUT

17.4.1 Whilst the functionality of the electrical supply and control elements of a lighting system is an important maintenance issue, it is the availability of the specified beam correctly aimed and emitting the correct colour that is often difficult to achieve. These parameters are the most common cause of substandard lighting performance. When a lighting system is installed, it should be capable of emitting intensity values shown in Annex 14, Volume I, Appendix 2, Figures 2.1 to 2.21. The maintenance objective must be to sustain the overall performance at these levels. However, it is not practicable to maintain the specified intensities at all times for every light in the system.

17.4.2 Experience has shown that maintenance of lighting performance to the full Standards specified in Annex 14, Volume I, cannot be achieved by visual inspection and maintenance schedules alone. This technique, at best, identifies lamp failures, gross misalignments and structural damage. The operational performance of the lighting depends on clean, accurately aligned lights emitting the prescribed beam. Therefore, as indicated above, Annex 14, Volume I, recommends that a means of monitoring the in-service performance of individual lights included in approach and runway lighting systems for a precision approach runway Category II and III should be employed using mobile measuring equipment.

17.4.3 The frequency with which the measurements need to take place to achieve the maintenance objectives has to be determined for each location. It will be influenced by several factors including traffic density, the levels of pollution and the reliability of the lighting equipment. At some aerodromes, the measurement frequency may need to be weekly. At many aerodromes, a monthly, or longer, measurement interval may be sufficient once the lighting system has been brought up to the required standard.

17.4.4 It is important that measurements can be made in a short period of time to reduce the requirements for runway access. This is particularly so at busy airports. A vehicle speed in excess of 50 km/h is generally found to be acceptable.

17.4.5 The test equipment should measure and record the isocandela diagram, alignment and color of each light, the tests being made with the lighting operating at the 100 per cent power supply level.

17.4.6 Means should be provided for analysing and displaying the recorded data in a manner that facilitates assessment of compliance with specifications. In addition, it is recommended that the information should be displayed

in a manner such that diagnostic assessments to locate the cause of failures such as misalignment or repeated premature lamp failures at a specific location can be made.

17.4.7 It has been found beneficial to recommend that two levels of intensity should be defined for individual lights, i.e. a maintenance level and a failure level. The higher level should be set to give maintenance personnel advance warning that a light unit is beginning to produce an output significantly below the value specified in Annex 14, Volume I. This level will always be above 50 per cent of the specified intensity, which is the level at which the light is classed as being outside specification tolerance and therefore to have failed from an operational perspective. Once the light output reaches the higher level, corrective action can be scheduled. This should prevent lights from losing performance to the level where immediate maintenance action must be taken.

17.4.8 Experience with the introduction into service of equipment complying with the above guidance has clearly demonstrated that, after an initial period of heavy maintenance, the use of a mobile in-service measurement system has significant operational and economic benefits. Aerodromes regularly using a measurement device are able to implement an effective maintenance plan and as a result are able to readily demonstrate compliance with performance specifications. At the same time, the total amount of maintenance effort is reduced significantly, thereby reducing costs.

17.4.9 An example of the improvement in performance that can result from the use of such a system is illustrated below. In Figure 17-1, the average intensity within that part of the beam enclosed by the inner isocandela curve is shown for the centre line lights of a runway designed to support operations in very low visibility. The data represent a typical result at an airport that uses a combination of visual inspections, corrective maintenance and bulk change techniques. The example is definitely not the worst situation that can and does occur at aerodromes which conduct regular visual inspections. After implementation of a mobile in-service measurement system, together with the application of an appropriate maintenance regime based on the data provided by the measurements, the same runway centre line produced the results shown in Figure 17-2. The maintenance regime used to achieve the results shown in Figure 17-2 does not use a bulk lamp change technique. Rectification is only applied to those fittings that are shown to be non-compliant by the mobile monitoring equipment (differential maintenance).

17.4.10 A comparison of the two figures clearly shows the benefits that can be obtained by the introduction of a

regular regime of light monitoring in support of the maintenance activity. Repeated use of the mobile system identifies a number of ways in which performance is adversely affected. In most instances, the largest and most common cause is the accumulation of dust and other contaminants on the optical surfaces. At busy airports, the rate of contamination may be shown to be such that a weekly or fortnightly cleaning of the lights may be required to maintain the specification, particularly for some of the inset runway lights in the touchdown zone area.

17.4.11 Once a cleaning regime at an appropriate interval has been established for a runway, then other causes of failure can be identified. In some instances, particular light units will repeatedly fail the test criteria. Inspection of the recorded data may show that the light beam is incorrectly orientated, hence the substandard readings within the test area. This may be due to such causes as misalignment of the light fitting in the seating ring, filament sag, or movement of optical components within the fitting. The data may also reveal particular light fittings that repeatedly fail the test due to lamp outage. This type of failure can be caused by an electrical fault in, for example, the supply transformer. Without regular, recorded monitoring this type of failure is not easily detected and identified with the result that frequent and ineffective maintenance is carried out at that particular light fitting location.

17.4.12 The effects of misalignments are illustrated in Figure 17-3A. In the example given, the light unit is below the acceptable level of performance because the beam is not correctly orientated. If the beam were realigned to coincide with the specified area, the light would be compliant as shown in Figure 17-3B.

17.4.13 An example of mobile measuring equipment is shown in Figure 17-4. An array of photocells attached to a vehicle passes through the beam of each light in turn. The resulting intensity samples are used to construct an isocandela diagram for each light, and the data are recorded in the vehicle for subsequent analysis. Equipment of this type can be adapted to measure the various lighting elements of the runway and the taxiway centre line lighting. Experience has shown that these are the most important lights to sample regularly and frequently. Generally the output of inset lighting is deficient because of contamination and faults in the optics, whereas elevated lighting is primarily affected by misalignment of the complete light fitting.

17.4.14 The monitoring of trans-illuminated signs can also be achieved by a sensor system that samples the light output from the sign and records the results for subsequent analysis. One such system uses a charge coupled device (CCD) camera as the sensor.

17.4.15 Approach lighting outputs are more difficult to monitor. For this lighting, an airborne inspection method using cameras and image processing techniques offers one potential means of achieving the maintenance goals. Visual approach slope indicators can be monitored by photocells placed in front of the projectors.

17.4.16 The safe and efficient operation of aircraft at aerodromes requires that lighting systems always provide in-service outputs that are compliant with the specifications of Annex 14 Volume 1, Chapter 5. Only by in-field measurements is it possible to ensure this level of com-

pliance. Mobile measurement systems that can characterize the light output within the areas specified in Appendix 2 of Annex 14, Volume I, are a proven means of demonstrating compliance. If the accuracy and resolution are comparable to the levels used in laboratory testing, then aerodrome operators can demonstrate compliance to regulatory authorities and can develop an efficient maintenance regime of cleaning, realignment, overhaul and repair.

17.4.17 Mobile monitoring of the in-service performance of lighting not only provides the data required for

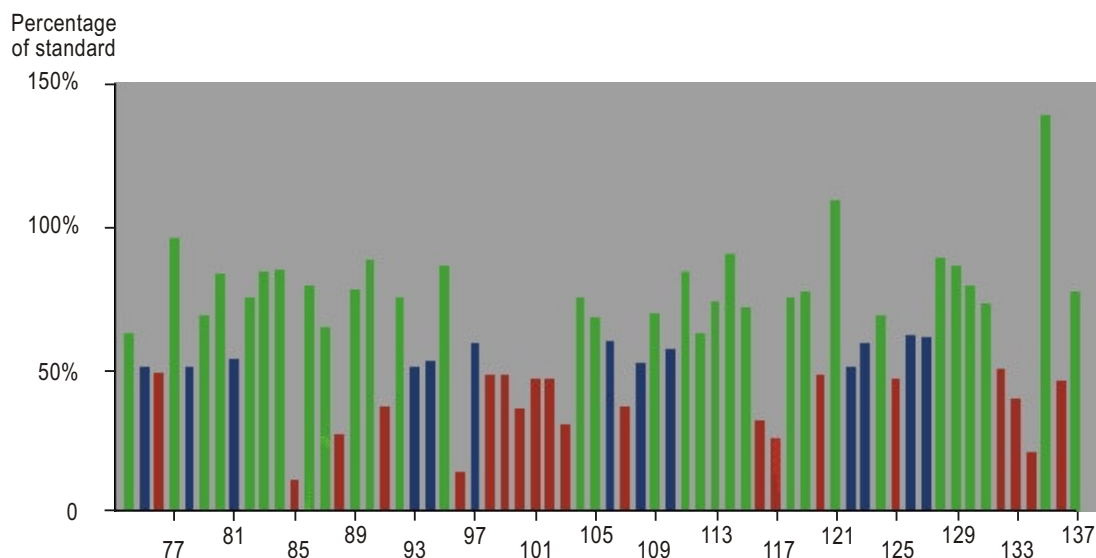

NOTES:

1. The average intensity within that part of the runway centre line beam enclosed by the inner isocandela curve is shown for lights in a section of a Category III runway. The average intensity is calculated using data obtained by a mobile measurement system.
2. The numbers on the horizontal axis of the figure identify specific light positions in the centre line light pattern that is being monitored. The vertical axis indicates the average intensity measured for each light as a percentage of the average intensity specified in Annex 14, Volume I, Appendix 2, Figure 2.7.
3. The intensity data is colour-coded to facilitate the application of differential maintenance techniques. The priority for maintenance action can easily be seen by the use of this type of coding in the data presentation. For the purposes of this illustration, the following colour coding has been applied:

Red: less than 50 per cent of specified intensity

Blue: between 50 per cent and 60 per cent of specified intensity

Green: above 60 per cent of specified intensity

Figure 17-1. A Category III runway before differential maintenance

compliance validation but it also leads to cost-benefits by targeting maintenance on those light fittings that need attention, thereby reducing the volume of maintenance activity.

17.5 DEMONSTRATION OF CONFORMANCE

17.5.1 Regulatory authorities may publish guidance on the means by which conformance with the lighting standards can be demonstrated. The following paragraphs are based on such a document published in one State.

17.5.2 Conformance with photometric standards may be demonstrated by the use of mobile measurement equipment. In some cases, however, it could simply be a matter of measuring a sample of the lights using a suitable measurement procedure involving the use of a hand-held photometer. The mobile measurement equipment is of

benefit where the manual procedure is insufficiently accurate, or efficient, or does not provide a proper representation of the complete lighting system.

17.5.3 High-density aerodromes, where all-weather operations with large jet transport aircraft are conducted, are less likely to meet the standards. Therefore, the use of mobile photometric measurement is encouraged to complement the routine lighting maintenance activities. There is evidence that significant benefits can be achieved for large aerodromes by using mobile photometric measuring equipment, including significant cost savings resulting from targeting maintenance activities. The frequency of photometric measurement required will depend on many factors, including traffic density, weather conditions, the season, etc.

17.5.4 The ability to perform mobile photometric measurements, which may take 10 to 15 minutes per survey, is another factor to take into consideration. Traffic levels may not always allow sufficient time on the runway, even

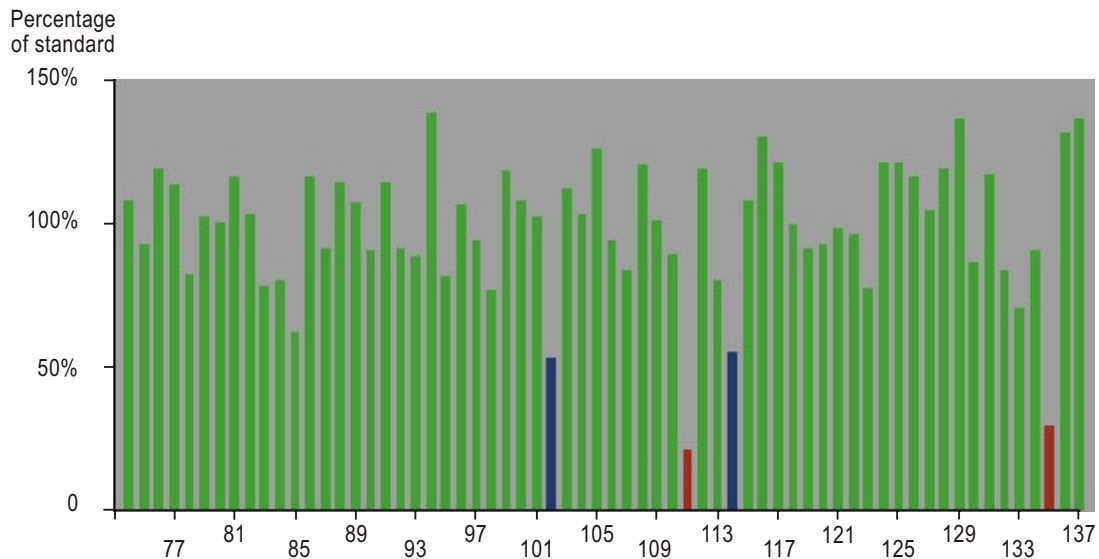

NOTES:

1. The data presented in this figure is coded in the same manner as the data presented in Figure 17-1.
2. The benefits that can result from the use of a mobile measurement system together with the use of differential maintenance based on the data displayed can be seen by comparing the data presented in Figure 17-1 and Figure 17-2.

Figure 17-2. The same Category III runway after differential maintenance

though measurements are normally carried out at night. The runway may also need to be dry. Nevertheless, aerodrome operators should endeavour to maintain credible measurement records. Thus, it may be necessary to plan for a measurement every night for some runways and take advantage of measurement opportunities as they arise. In general, infrequent photometric measurements performed only after cleaning activities have been completed will be unacceptable.

17.5.5 Smaller aerodromes with relatively low movement rates and no traffic with large jet transport aircraft

tend to have lesser aerodrome ground lighting facilities. In this case, the performance of the lights does not usually suffer the same level and rate of degradation, and a robust maintenance regime based on regular inspections and cleaning, and routine flight inspections should be adequate. However, photometric measurement may still enhance the efficiency of the maintenance activities at these aerodromes. Since photometric measurement to demonstrate conformance with the requirements need not be performed as often as for larger systems, a lease or contract arrangement may be more cost-effective than investment in mobile measurement equipment.

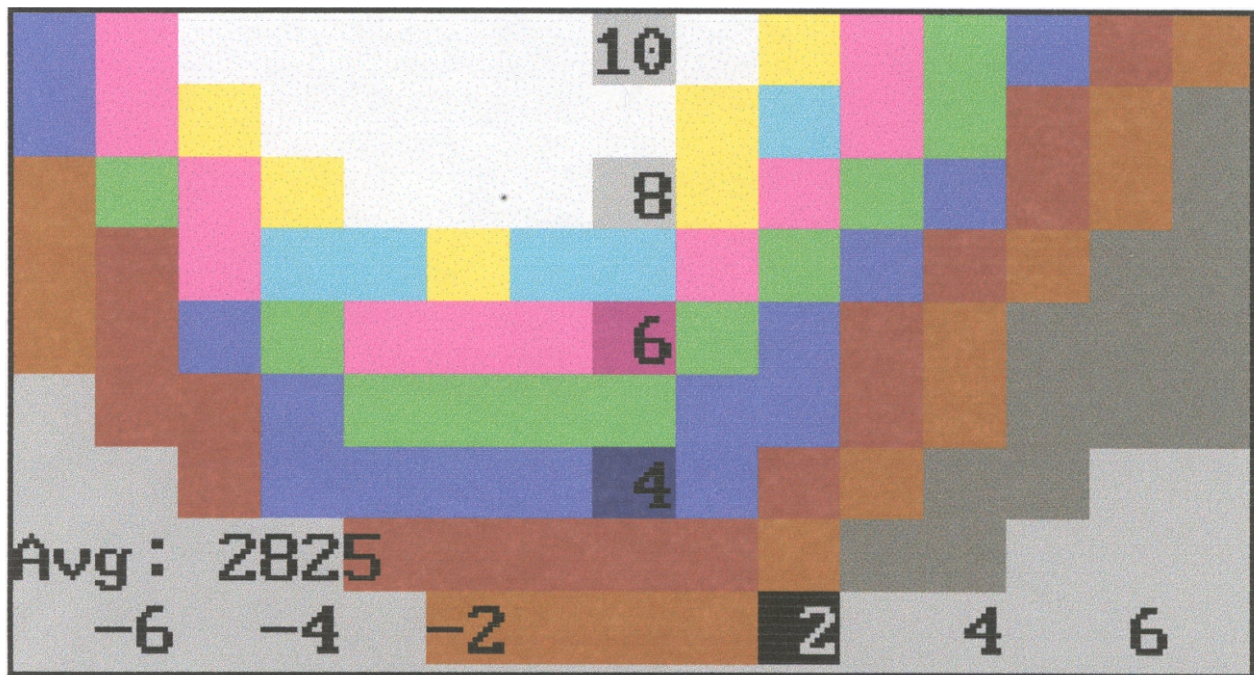

Note.— The data presented in Figure 17-3A is from a light that is non-compliant. The average intensity is less than the specification and the beam is evidently misaligned.

Figure 17-3A. Data from a light that is misaligned

17.5.6 The photometric measurement of some approach lighting systems to the same degree of accuracy as runway lighting can be difficult to achieve. The physical location of the approach lights makes the use of measurement tools difficult. However, in many cases, the lights within the inner 300 m are installed at ground level or in the pavement and may be measured successfully. This part of the approach lighting pattern is the most critical for Category II and III operations and influences the smooth

transition from approach to runway visual cues. Without an effective means of measuring the performance of the approach lighting, it is possible that, contrary to the objective of providing a balanced overall visual pattern, there will be a marked difference in the visual perception of the approach lights compared to the runway lights. Therefore, if photometric measurement of approach lighting is not practicable, regular visual flight inspections should be carried out until a practicable means can be identified.

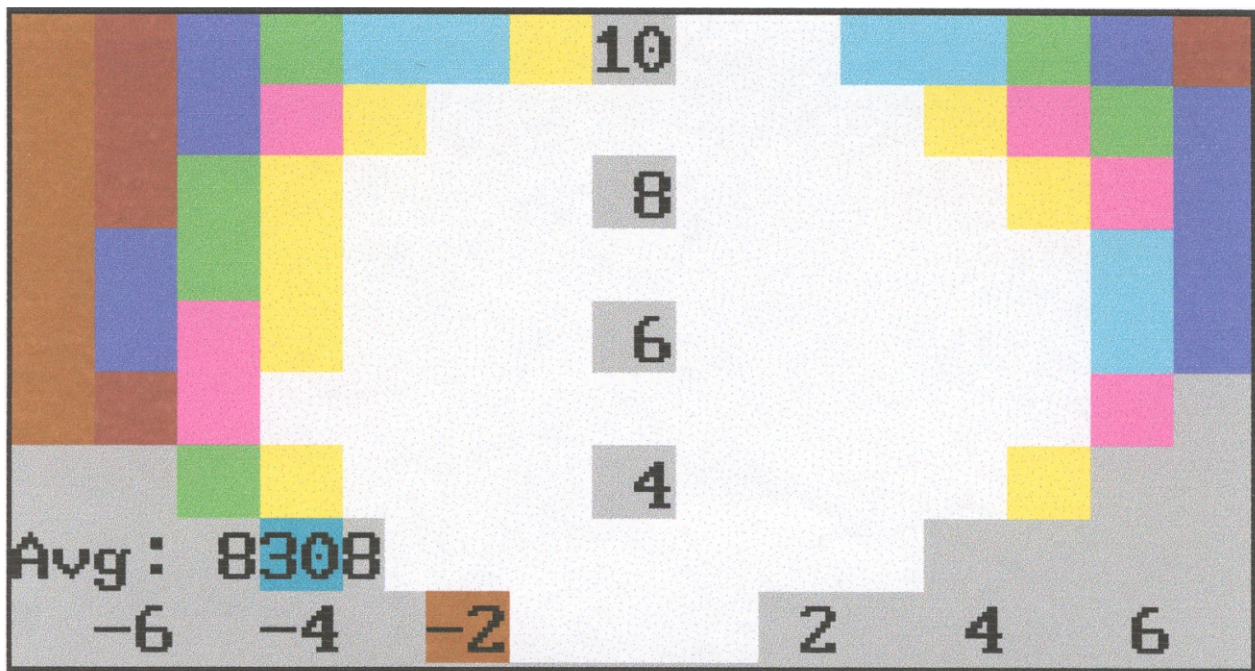

Note.— The colour-coded data in Figure 17-3B illustrates how data from a light that is correctly aligned and emitting light of intensity sufficient to meet the requirements can be presented for evaluation by maintenance personnel.

Figure 17-3B. Data from a light that is correctly aligned

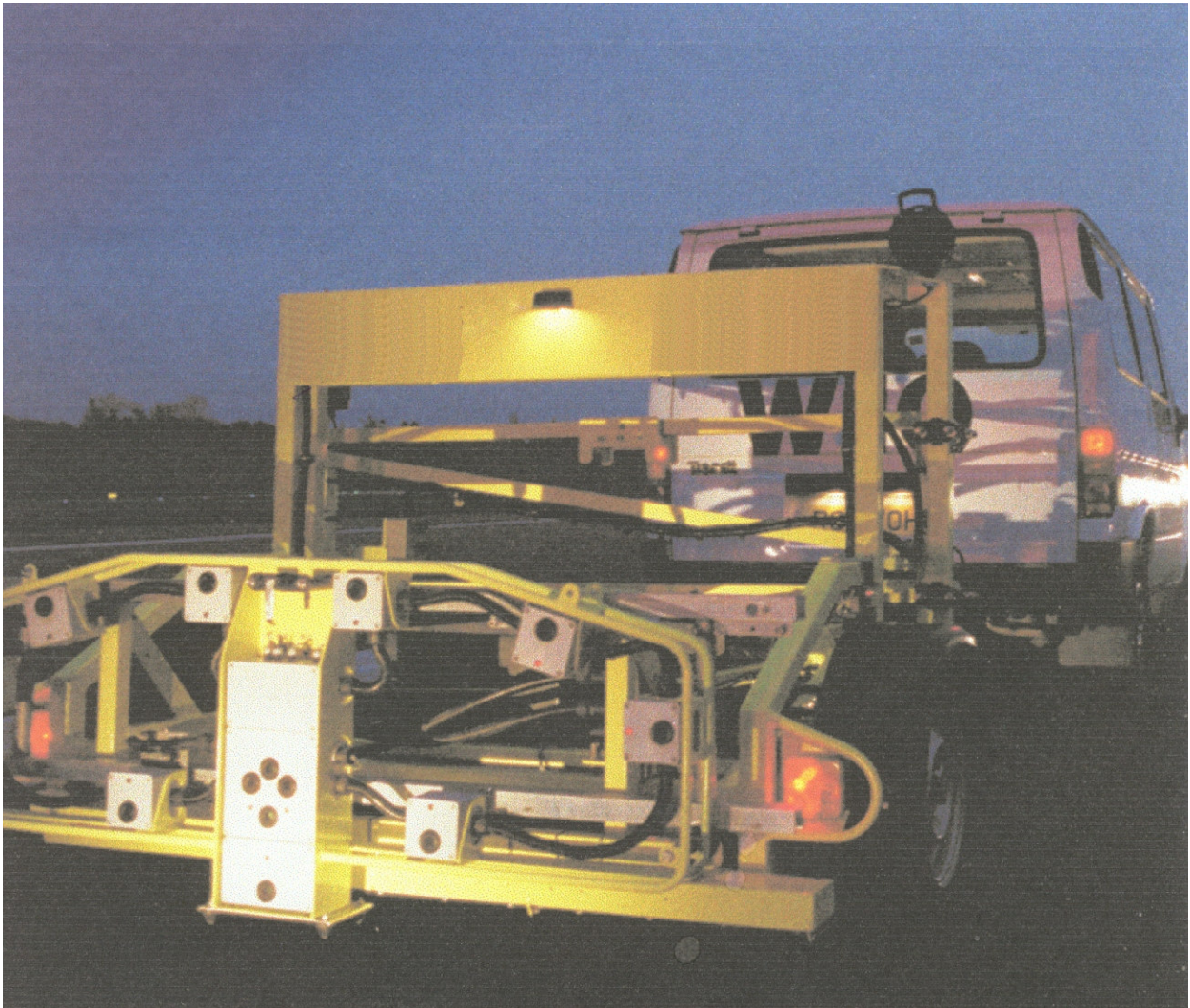

Figure 17-4. An example of mobile measuring equipment

Chapter 18

Measurement of the Light Intensity of Steady Burning and Flashing Lights

18.1 INTRODUCTION

18.1.1 Aeronautical ground lights, with the exception of guidance sign luminaires, commonly provide a point source signal that is viewed by aircraft, either at great distances whilst proceeding to a landing (e.g. approach and runway lights) or at relatively close distances for manoeuvring guidance on the airfield (e.g. taxiway lighting). In both instances, Annex 14, Volume I, Appendix 2, specifies these lights in terms of luminous intensity (candela) through the use of isocandela diagrams. For many aeronautical ground lights, colour is also part of the specifications. Annex 14, Volume I, Appendix 1, makes recommendations for colour measurement when evaluating light. In addition, other applicable criteria are to be found in the main body of the Annex.

18.1.2 When selecting lights for installation on site, compliance with the specifications, including colour specifications, will have to be demonstrated. This may be done either through attestation by an accredited laboratory or through a manufacturer having accredited facilities and procedures.

18.1.3 Light intensity measurement techniques and the required quality of measurement and equipment (detectors, goniometer, etc.) are well described in other reference sources. The purpose of this guidance material is to detail criteria which are specific to aerodrome applications, such as the distance of measurement, the calculation of average intensity, conformance to minimum and maximum values within the main beam, conformance to minimum values within the outer isocandela boundaries, and tolerances. In the case of lights that have a flashing characteristic, a description is given in 18.3 of the method of calculating effective intensity, which is defined as the intensity equivalent to that of a steady burning light to produce the same visual range for the eye.

18.2 CRITERIA

Distance of measurement

18.2.1 The longest dimension of the luminous source and the number of sources that may be used to create an aeronautical ground light varies. To achieve accurate and repeatable results, it is recommended that the distance of measurement should not be less than 100 times the aperture of the light. Typically, this will be 20 m for a single light source and not less than 30 m for a multiple light source, such as high-intensity obstacle lights and visual approach slope indicators.

Measurement set-up

Aging of lamps

18.2.2 Measurements should be taken with the lamp operating at a level of luminous flux emission that is representative of the level to be used in service. Therefore, prior to conducting measurements, the lamp should be aged to at least one per cent of the rated life published by the manufacturer. Fluorescent or other lamp types should be referred to the lamp manufacturer to establish a representative level.

Reference axis

18.2.3 The light unit should be set up on the goniometer in such a way that the reference axis will replicate the alignment that will be used when the fitting is installed for use. This requires the establishment of the mechanical centre of the unit rather than the optical beam centre. The optical beam centre may be designed not to be

coincident with the mechanical centre for some types of lights. If the light unit is set up on the basis of the optical beam centre, then any specified horizontal toe-in angle will not be verified, since the photometric centre of the beam may not necessarily be the point of highest intensity. For runway and taxiway light units, the horizontal axis runs through the centre of the light unit and is parallel to the centre line. The vertical axis runs through the centre of the light. The manufacturer should be consulted for proper placement and orientation of the lamp within the light unit.

18.2.4 In the case of inset lights, the in-service output may be affected by the manner in which the light unit is installed. Some manufacturers may recommend in their instruction manuals that the light unit should be installed at some distance below the surrounding pavement to lower the profile and thus avoid damage from snowploughs. If this is the case, then the measurement to be made in the laboratory should include some means of simulating the resulting obstruction of the lower part of the beam by the pavement. For the purpose of laboratory testing, the pavement should be considered as a horizontal plane without any slope.

18.2.5 Every attempt should be made to ensure that the reference axis is correctly set up and does not incorporate a horizontal offset or a vertical error in the height of the filament location. In the case of inset lights, the horizontal orientation is established by the symmetry of the unit. The horizontal and vertical positioning of the light unit should be set up within an accuracy of ± 0.1 degrees.

18.2.6 The measured light intensities should be corrected with respect to the rated nominal luminous flux of the lamp as specified by the manufacturer. For example, a light unit may be found to produce an intensity of 14 000 cd for a luminous flux of 2 800 lumens. If the manufacturer publishes a rating of 2 400 lumens, then the recorded intensity should be corrected as follows for the compliance record:

$$14\ 000\ \text{cd} * (2\ 400/2\ 800) = 12\ 000\ \text{cd}$$

Number of tests

18.2.7 At least 5 light units, each with their own lamp, should be tested. There should be a consistency of results demonstrating that the light unit design performance is repeatable for the production line. A value such as 5 per cent intensity variation between units may be chosen as a measure of the required consistency.

Colour measurement

18.2.8 The colour emitted by the light unit should be verified in accordance with Annex 14, Volume I, Appendix 1, 2.2.4, when operating at rated current or voltage. It should be within the chromaticity boundaries of Annex 14, Appendix 1, Figure 1.1, for the horizontal and vertical limits of the main beam (in the case of elliptical or circular isocandela curves) or the limits of the diagonals of the main beam (in the case of rectangular isocandela curves). Furthermore, the colour should be checked by measurement at similar limits for the outermost isocandela curve. This latter check is to ensure that there is no unacceptable colour shift (e.g. red to yellow) at large angles of observation. Such colour shift can occur with some types of filter material depending upon the design details of the light unit. If the colour shift is outside the chromaticity boundary for that colour, the appropriate regulatory authority should be consulted for judgement of the acceptability of the amount of colour shift.

Note.— The above-mentioned check of colour coordinates may be extended at the request of the appropriate authority to cover angles outside the outermost isocandela curve. This may be an important precaution for light units that have applicability where the angle of observation by the pilot can be outside the angles specified in the isocandela diagram (e.g. stop bars at wide runway entrances).

Isocandela diagram

18.2.9 Measurement of conformance to the isocandela diagram involves a number of criteria. The first step is to obtain the intensities at spatial points over the horizontal and vertical ranges, as indicated by the grid of the applicable isocandela diagram. For example, in the case of an elevated runway edge light (Annex 14, Volume I, Appendix 2, Figure 2.10 refers), the beam centre shall have an elevation angle of 3.5 degrees. Furthermore, a note should be provided beneath the diagram stating a horizontal toe-in angle of 4.5 degrees. It is important to realize that some lights have a toe-in angle, and that this is not indicated on the diagram itself, since the latter serves only to illustrate the distribution around a theoretical beam centre. Where the elevation or toe-in angle is designed into the fitting (e.g. inset runway lights), the presented data should clearly indicate this fact.

18.2.10 For the given example, the outer boundary (5 per cent) has a range of ± 10 degrees. It is suggested that in order to verify the location of the main beam and to

allow for later application of tolerances, the actual measurement be done with an extension of at least 2 degrees. Thus, the horizontal range measurements would be $10 + 2 + 4.5 = 16.5$ or 17 degrees to $10 + 2 - 4.5 = 7.5$ or 8 degrees. In the isocandela diagram, the outer boundary has an upper vertical limit of 12 degrees and the lower edge of the main beam is zero degrees. In order to allow later application of tolerances, it is suggested that the actual vertical measurements be done over a range of $12 + 2 = 14$ degrees and $0 - 2 = -2$ degrees.

18.2.11 Although the calculation of average intensity, as discussed below, is based upon values at one-degree increments, measurements should be done at half-degree or smaller increments. This will enable proper assessment of light units, the theoretical beam centre toe-in and/or elevation angles of which are fractional numbers (e.g. 4.5 and 3.5 degrees respectively), as well as the assessment of the application of tolerances.

Average intensity

18.2.12 Annex 14, Volume I, Appendix 2, Figures 2.11 and 2.21, indicate the grid points at which measured intensities are to be incorporated into a calculation of average intensity. In the case of a runway edge light, the boundary is elliptical in shape, and the pertinent points are to be found within the main beam isocandela boundary except for horizontal and vertical limits. In the case of taxiway centre line lights, the boundary is rectangular so that points along the boundary are included if this boundary is on a grid line. The average intensity is calculated as the sum of all the intensity measurements of the identified points divided by the number of measurements.

18.2.13 In Figure 2.11, the horizontal limits of the main beam are at ± 6.5 degrees. Therefore, some grid points are not included in the calculation of average intensity. However, this figure is a typical illustration of method and whether the measurements at certain grid points are to be included in the calculation of average intensity depends upon the amount of toe-in. For example, a fraction value of toe-in (e.g. 4.5 degrees) will shift the figure so that the extremities of the ellipse reach a line of the grid, and thus these measurements at these points would be included in the calculation.

Minimum and maximum values

18.2.14 It is intended that the beam shall have a certain uniformity without significant low or high intensities.

Therefore, in accordance with Annex 14, Volume I, Chapter 5, 5.3.1.12 and 5.3.1.13, within and on the boundary of the main beam, the individual intensities are required to be not less than a minimum which is half the average intensity and not more than a maximum which is three times the minimum (one and a half times the average). In effect, a uniformity ratio such that the individual intensities are to be with ± 50 per cent of the average. For example, if the measured average intensity is 240 cd, then the minimum is 120 cd and the maximum 360 cd.

Minimum values for outer isocandela boundaries

18.2.15 It is also intended that the photometric distribution should be continued in a uniform fashion within the other isocandela boundaries. Thus, within the areas defined by the isocandela boundaries, the individual intensities should not be less than the values identified at each boundary.

Tolerances

18.2.16 In determining compliance with the main beam average intensity and minimum intensity values within the outer boundaries, the grid should be located such that one point is coincident with the intersection of the horizontal and vertical axis defined in 18.2.3.

Omnidirectional light units

18.2.17 In the case of omnidirectional light units, measurement of intensity should be made for a grid of one-degree increments vertically and thirty-degree increments horizontally. For each vertical scan, the measured values should meet the minimum requirement, and the calculated average of these values should meet the minimum average intensity value. The light unit should be inspected for the presence of any internal supports or other structures that might cause an obstruction of light output. Where there is a possibility of obstruction, the reduction of intensity within the one degree should not be less than 75 per cent of the minimum.

Note.— For small low-intensity lights, a photometric measurement distance less than 20 m may have to be used, but it should not be less than 3 m. The validity of any measurements can be proven by taking measurements at a series of increasing ranges and comparing the resultant intensity values. This should enable a range to be established beyond which the calculated intensity remains

constant. This range can be considered to be the minimum acceptable measurement range for the type of light being tested.

Site standard

18.2.18 All specified isocandela values are minimums. Thus a light unit can be manufactured that significantly exceeds the required specified intensity. There is no maximum limit specified for the output of any light. Assuming a requirement of 200 cd average (e.g. Annex 14, Volume I, Appendix 2, Figure 2.13), a light unit may be deemed to be in conformance if its average intensity just meets this requirement or is significantly in excess of the requirement, as long as these lights each have a uniformity ratio of ± 50 per cent within the main beam. If all available light units deemed to be in conformance with Annex 14, Volume I, are treated equally for procurement, there is a potential for imbalance of display from one lighting system to another of the same type. For example, if we take the aforementioned example, and an installation is done with light units just meeting the 200 cd average requirement, a further procurement of units having a 600 cd average will immediately create an imbalance of display of 3 to 1. If the former units are repaired on the basis of occurrence of failure to half the original output (down to 100 cd) and the latter are still in full operating condition, the imbalance can be of the order of 6 to 1. Thus, aerodrome operators should be aware of the level of light output from the units first procured. This establishes a site standard, and future procurement of new lighting systems or replacement of light units should be of the same level. Similar considerations should apply in relation to the intensity ratios established between runway edge lights, runway centre line lights and approach lights (1.0:0.5:2.0).

18.3 FLASHING LIGHTS

18.3.1 It is generally recognized that when a light signal consists of separate, short-duration flashes, the maximum intensity during the flashes cannot be used to estimate the detection range of the signal (as is done for steady burning lights using Allard's Law). Blondel and Rey found that the threshold illumination for detection of an abrupt flash (a flash producing a relatively constant illuminance throughout its duration) is:

$$E = E_o \frac{a + t}{t} \quad (1)$$

where E_o is the threshold illuminance for a steady burning light, t is the flash duration, and a is a constant equal to 0.2 when t is in seconds.

18.3.2 It is convenient to calibrate flashing lights in terms of their effective intensity. A light of a given effective intensity will have the same range performance as a steady light having the same numerical value. Thus,

$$I_e = \frac{I * E_o}{E}$$

where I_e is the effective intensity, and I is the instantaneous intensity producing the illuminance E .

For an abrupt flash of constant illuminance:

$$I_e = \frac{I * t}{a + t} \quad (2)$$

18.3.3 The intensity of airport flashing lights, however, is not abrupt but rises and falls gradually and may vary appreciably during the flash. If the flash duration is very short, or if the times of rise and fall of intensity are short in comparison to the flash duration, only small uncertainties would be introduced in the determination of flash duration by the product of the peak intensity and the flash duration for the quantity $I * t$. However, in many cases, significant errors would be introduced, and some modification of equation (2) is necessary.

18.3.4 Many evaluations of flashing lights therefore measure the output in terms of candelaseconds in the flash, integrating over the period of the flash, that is:

$$\text{Candelaseconds} = \int_{t_1}^{t_2} I dt$$

where I is the instantaneous intensity and $t_2 - t_1$ does not exceed 0.5 seconds.

18.3.5 When the specification for aircraft anti-collision lights was being drafted, it was suggested that equation (2) be modified so that:

$$I_e = \frac{\int_{t_1}^{t_2} I dt}{0.2 + (t_2 - t_1)} \quad (3)$$

18.3.6 The meaning of the integral $\int Idt$ and the times t_1 and t_2 is illustrated in Figure 18-1.

18.3.7 Rather than using an arbitrary set of limits, such as choosing for t_1 and t_2 the times when I is 10 per cent of the peak intensity of the flash, it is recommended that limits be chosen which produce a value of I_e that is a maximum when the limits of t_1 and t_2 are the times when the instantaneous intensity is equal to I_e . Since both the instantaneous intensity I and the times t are unknown, this leads to a process of repeated calculations to maximize I_e . It is of importance to note that the times t_1 and t_2 are not the times at the exact beginning and at the exact ending of the flash, but some period later and before respectively in order to maximize I_e .

18.3.8 The calculation can be simplified where the flash duration is a few milliseconds, in which case the value of $(t_2 - t_1)$ is such that $[0.2 + t_2 - t_1]$ tends towards 0.2 seconds and the effective intensity is then found from the equation:

$$I_e = \frac{\int Idt}{0.2} = 5 * \int Idt \quad (4)$$

where $\int Idt$ is integrated over the entire flash cycle.

In this instance, I_e can be established by using an integrating detector to measure and record the value of the flash in candelseconds and multiplying this value by 5.

18.3.9 The signal from a flashing light may consist of single flashes of light, with the interval between the flashes so great that each flash has little influence on the effective intensity of the subsequent flashes. If the intensity required in a given set of circumstances to make a light visible is less than I_e , the flash may in that case be seen as a continuous flash with two peaks. However, if the threshold intensity is about equal to I_e , two separate flashes will be seen. The maximum distance at which the light can be seen will be determined by the effective intensity of a single flash computed over the time interval t_1 to t_2 .

18.3.10 Lights can be designated to produce a number of very short flashes in rapid succession so that the group of flashes is seen as a single flash. If, in a group of flashes, as shown in Figure 18-2, the periods during which the instantaneous intensity of the light is below the effective intensity of the flash are of the order of 10 milliseconds or less, the eye will perceive this group as a single flash.

18.3.11 The effective intensity should then be computed by equation (5), choosing as times t_1 and t_2 the

first and the last times the instantaneous intensity is I_e . Note that I_e is the effective intensity of the group and not that of a single flash.

$$I_e = \frac{t_1 \int^{t_a} Idt + t_b \int^{t_c} Idt + t_d \int^{t_e} Idt + t_f \int^{t_2} Idt}{a + (t_2 - t_1)} \quad (5)$$

18.3.12 Experience indicates that if the times chosen for the initial integration are the times when the instantaneous intensity is about 20 per cent of the peak intensity, only one additional step is required to obtain the value for the effective intensity, which is within one or two per cent of the maximum value. This is within the limits of accuracy with which the integral is evaluated by means of a planimeter. Often a single computation is sufficient if, instead of using as limits for the initial integration the times when I_e is 20 per cent of the peak intensity, the times used are the times when the instantaneous intensity is equal to the product of the peak intensity and the number of seconds between the times when the instantaneous intensity is roughly 5 per cent of the peak intensity.

Transition to steady burning measurement

18.3.13 For some lights, the time duration of flash can be sufficiently long that the error is not significant if the flashing mechanism is disabled and the intensity is measured with the light operating in the steady burning mode. This would be the case when the time duration of flash is more than 200 ms (0.2 s). Thus, runway guard lights, certain rotating aerodrome beacons, medium-intensity red incandescent obstacle lights, etc., may be measured as steady burning.

Measuring method

18.3.14 Flashing light units, with the exception of runway guard lights, are not specified in Annex 14, Volume 1, by means of isocandela diagrams. Therefore, the measurement of intensities involves a verification to minimum requirements at specified spatial points and minimum vertical beam spreads. In addition, for capacitor discharge light units:

- a) testing should be conducted with the maximum length and actual size of cable as would be used for the most critical installation;
- b) the measurement should begin after at least 10 minutes of operation;

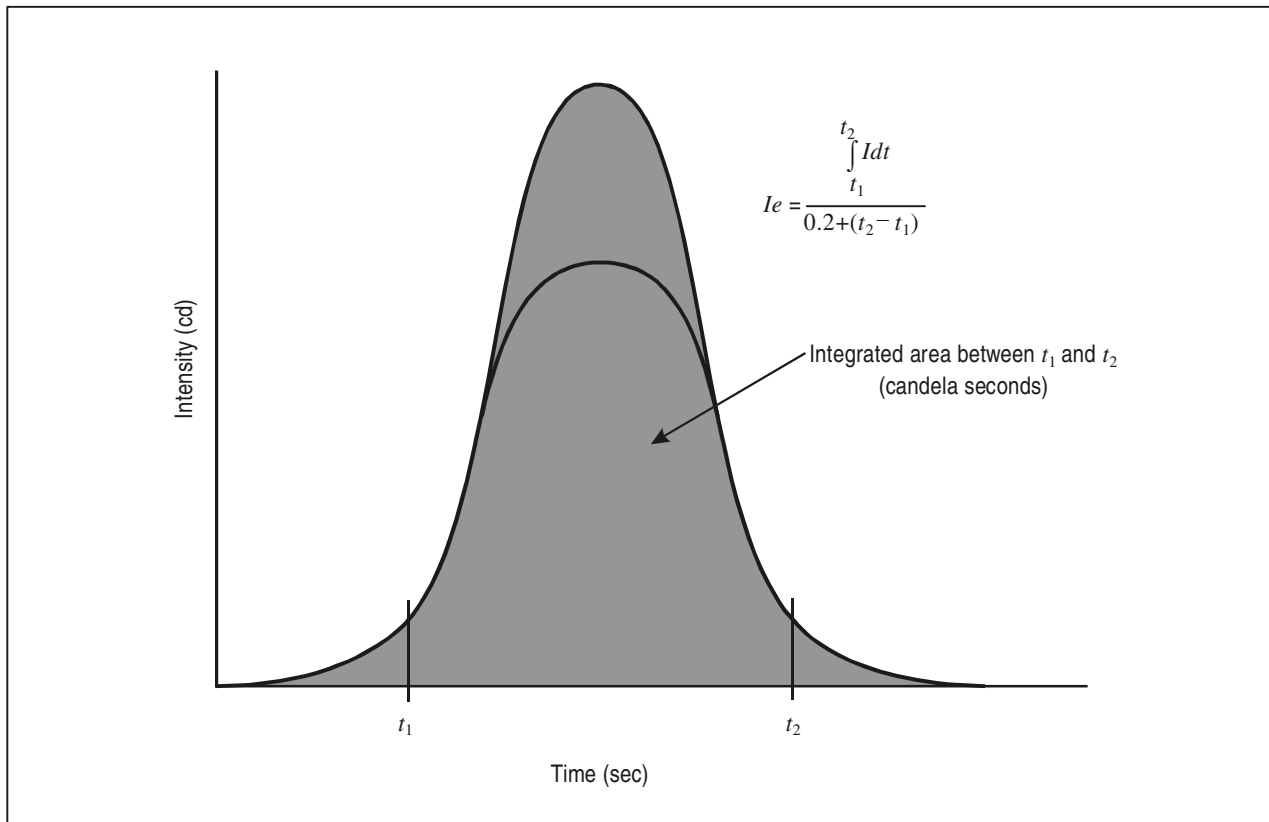

Figure 18-1. Typical flashing light that rises and falls gradually

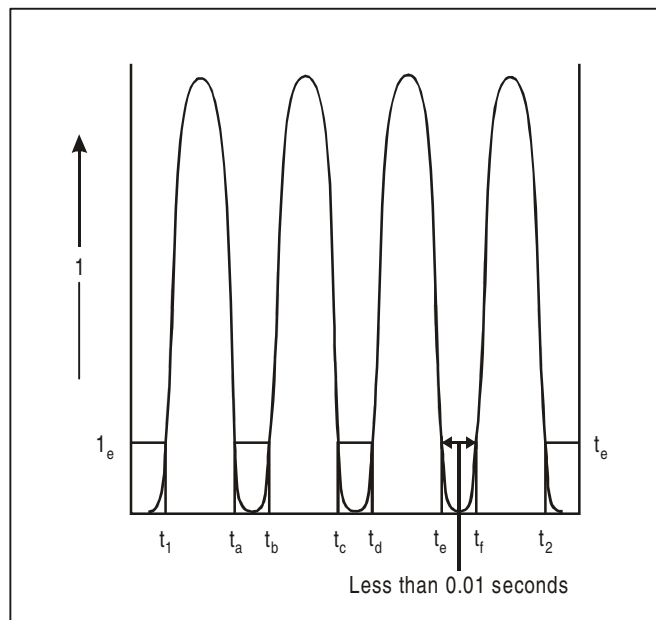

Figure 18-2. Flashing light producing very short flashes

- c) the flash failure rate should not be more than 1 in 100; and
 - d) the discharge can be somewhat unstable such that the peak intensity is not exactly repeatable for each flash. Thus, measurement for a sequence of short individual flashes should be made by averaging over at least 5 flashes to obtain an average value of candela seconds and then multiplying this result by 5.
-

Appendix 1

The Operational Requirements of Visual Nose-in Docking Guidance Systems

1. The system must provide positive visual lead-in guidance and when in use must be visible to the pilot throughout the docking manoeuvre.

2. The guidance provided must be easily recognizable and capable of being interpreted without ambiguity.

3. There must be continuity between the visual parking guidance and the visual docking guidance systems.

4. The displays must be readily conspicuous to a pilot approaching the system regardless of other distractions in the area.

5. Mounting of the unit above apron level should not be critical in relation to the pilot's viewing angle as the aircraft closes in on the stand.

6. The system should provide left/right guidance utilizing self-evident signals which inform the pilot of the position of the aircraft in relation to the longitudinal guidance line.

7. The guidance provided by the system should be such that the pilot can acquire and maintain the longitudinal and stopping guidance without over-controlling.

8. The system should be capable of accommodating variations in pilot eye height including the effects of aircraft loading.

9. The system for providing left/right guidance should be aligned for use by the pilot occupying the left-hand seat.

10. The rate of longitudinal closure information should be associated with, or incorporated into, the system.

11. An unmistakable stop signal for each aeroplane type, preferably deployed permanently without need for selective operation by ground personnel, should be associated with the system. The method used to indicate the stopping point should preferably not require pilots to turn their heads and should be usable by both pilots.

12. The guidance provided should not be affected by external factors such as pavement condition, weather and lighting conditions.

13. The accuracy of the system should be adequate for the type of loading bridge with which it is to be used.

Associated requirements for docking

14. Docking serviceability/unserviceability information should be available and, in the latter case, the point where the pilot should stop the aircraft should be indicated.

15. The provision of a human safety monitor capable of indicating to the pilot the need for an emergency stop may be necessary.

Appendix 2

The Operational Requirements of Visual Parking Guidance Systems

1. The system must provide positive visual lead-in guidance and when in use must be visible to the pilot at all times.
 2. The guidance provided must be easily recognizable and capable of being interpreted without ambiguity.
 3. Identification of the stand should be clearly visible to the pilot well before the aeroplane has reached a position in the parking procedure beyond which it would be difficult to change its direction safely to proceed to a different stand.
 4. A uniform identification sign for aircraft stands should be incorporated into the system.
 5. There must be a clear visual signal associated with the system to indicate the start of the final turn where a final turn to the parking position is needed.
 6. Positive guidance is required for final alignment.
 7. A positive stop signal must be associated with the final alignment guidance.
 8. The method used to indicate the precise stopping point should preferably not require pilots to turn their heads.
 9. The system should be located using the aircraft nose wheel on guide line principle.
 10. Where it is necessary to indicate different stopping points for different aeroplane types, these should preferably be displayed permanently without reliance on human intervention.
 11. Continuous lead-out guidance may be required from the point where the pilot takes control of the aircraft, up to the point where the taxiway guidance can be used.
 12. In-pavement lights should preferably be used to supplement painted guide lines, turning points and stop indications. Selective operation should be provided when operating and visibility conditions so require.
 13. There should be a difference in colour between inset lights and taxiway centre line lights.
-

Appendix 3

Selection, Application and Removal of Paints

GENERAL

1. To ensure that runway and taxiway markings have adequate conspicuity and durability, care must be exercised in the selection and application of paint. Guidance on these factors is provided in this appendix. Repainting operations must be carefully safeguarded and coordinated with air traffic operations for the safety of aircraft and of the painting crews and equipment.

SELECTION OF PAINTS

Type of paints

2. Several types of paints have been developed which have been found acceptable for markings on pavements. Some of these paints are classified as oil base, rubber base, acrylic or vinyl base, oleoresinous base, and water emulsion base. Recently the bases have been modified in proportions and different types of solvent combined to improve certain characteristics of these paints for easier application, better storing and better performance. Since drying time is very important in the application of pavement markings on some surfaces, these paints may also be classified by drying time as follows:

- a) standard (conventional) dry — 7 minutes or longer;
- b) fast dry — between 2 and 7 minutes;
- c) quick dry — between 30 and 120 seconds; and
- d) instant dry — less than 30 seconds.

3. Two types of paints have been developed specifically for aerodrome markings. One type is an oil (alkyd) base paint, and the other type is a water emulsion base paint. Both types of paints are required to meet specified physical and performance tests. Both types of paints are available in white or yellow and may be used alone or to bind retro-reflective beads. A black oil base paint is also used on some aerodromes with light-coloured

pavements as a border around the markings to improve the contrast. A drying time of 30 minutes or less is usually acceptable before vehicle traffic can be permitted on the new markings without the paint being picked up from the pavement, adhering to the tires, or transferring to new locations on the pavement. The permissible time required for the paint of the indicated thickness to dry through the full coat may be up to two hours.

4. Other types of traffic-marking paints may prove to be suitable for aerodrome markings, but the performance of these paints should be carefully evaluated for the particular operating conditions before they are used. In some locations, paints with special qualities for application or resistance to unusual factors affecting the life of the markings may be required. Some conditions which may require special types of paints are very cold areas where the temperatures are often not high enough for painting, some abnormally wet or humid areas, areas where micro-organisms or plants attack the regular paint, and other unusual conditions. The lack of availability of aerodrome-marking paints may make it desirable to use another type of paint, such as highway traffic-marking paints although the performance and life of the markings may be reduced.

Type of pavement

5. Both of the aerodrome marking-type paints are usually suitable for application on pavement surfaces of portland cement concrete (rigid), bituminous/asphaltic cement concrete (flexible) and previously painted areas of these surfaces. The water emulsion base paint may be preferred for paved surfaces which have not fully cured, especially asphalt, because of its better performance against bleeding. Other types of paint may be satisfactory for one surface and not another.

Type of service

6. Typically markings on runways and taxiways do not fail from abrasive wear as do highway markings.

Instead, failure of threshold, touchdown zone, and runway centre line markings is caused by rubber deposited during the spin-up of the wheels of landing aircraft. Failure of the other markings, particularly side stripe markings, is usually caused by the effects of weather and the accumulation of dirt. Hence abrasion resistance is not a prime consideration in the selection of materials to be used for aerodrome pavement markings. A more suitable choice of marking materials is a paint which is compatible with the type of pavement, maintains good conspicuity and can be readily applied at the proper thickness. A wet-film thickness of 0.4 mm has been found suitable for most installations.

Coefficient of friction

7. Both standard aerodrome-marking paints provide good coefficients of friction on either portland cement concrete or bituminous cement concrete and normally furnish good braking performance. If better anti-skid properties for the marking areas are required, as may be the case when reflective markings are to be provided, calcined aluminium oxide and angular glass in sizes which will pass through sieves of 150 micrometre mesh and where less than 5 per cent will be retained by sieves with 45 micrometre mesh were found to be effective. The paint manufacturer's instructions on the amount of the additive to use and the mixing procedures should be followed.

Specification of paints

8. The performance of paints may vary appreciably with minor changes in composition. To ensure suitable quality, specification by performance of tests of desired requirements is preferable to specification by formulation. However, the tests must be carefully chosen to evaluate all the qualities essential to provide acceptable markings, must be practical to conduct and must reliably distinguish between adequate and unsatisfactory performance. The basic requirements of the pigment are colour, opaqueness and lasting quality. Suspending and dispersing agents may be used to prevent excess settling and caking. The vehicle or base of the paint provides many of the characteristics desired in storage, mixing, application and adhesion. Anti-skinning and antissettling agents may be included in the vehicle. The solvent or varnish determines the drying time and affects application, flexibility, adhesion, bleeding, skid resistance and pigment volume concentration. For some types of paint, minimum or maximum amounts of certain components of the solvents may need to be specified.

SELECTION OF RETRO-REFLECTIVE ELEMENT (GLASS BEADS)

Conditions for using reflective markings

9. Reflective aerodrome markings are used to improve performance of the markings at night, especially in conditions when the markings may be wet. Because of the additional costs, some authorities may use reflective markings only for those aerodromes which can benefit from the improved performance. Aerodromes which operate only during daylight or are used only by aircraft without landing or taxiing lights would not need to provide reflectorized markings. Reflective markings may not be necessary on runways with operating runway centre line and touchdown zone lights; however, the reflective markings may be helpful for night-time operations in clearer visibilities when the centre line and touchdown zone lights are not energized. Tests have shown that the reflectivity of markings may be enhanced by factors in excess of 5 by the inclusion of glass beads.

Specification of glass beads

10. The primary characteristics of retro-reflective beads to be considered in selection for aerodrome markings are composition, index of refraction, gradation and imperfections. Glass beads which are lead-free, uncoated, with a refractive index of 1.9 or greater, have size gradation between 0.4 and 1.3 mm diameter and have less than 33 per cent imperfections have been found best for aerodrome markings. Glass beads with a refractive index of 1.5, while not as efficient as beads with a higher refractive index, are beneficial in increasing the reflectivity of markings, and they are also less prone to mechanical damage in some circumstances. Therefore, in certain circumstances markings containing glass beads with a refractive index of 1.5 and markings containing glass beads with a refractive index of 1.9 or greater may prove equally efficient after a certain period of usage.

11. Because of the limited abrasion of runway and taxiway markings, the pre-mix of beads in the paint is not very effective. The method of applying the beads by dropping them directly onto the fresh, wet paint provides better performance. The beads must be dropped immediately onto the freshly applied paint, especially for instant dry paint, to obtain proper adhesion of the beads.

APPLICATION OF PAINTS

General

12. Before commencing the work, all materials and equipment for the work, including that necessary for properly cleaning the existing surfaces, should be approved by the engineer in charge of the project.

Pavement surface preparation

13. The pavement surface should be cleaned properly before initial painting and before repainting. The surface to be painted should be dry and free from dirt, grease, oil, laitance, loose rubber deposits, or other foreign material which would reduce the bond between the paint and the pavement.

14. Cold (normal temperature) paints should not be applied when the surface temperature is less than 5°C. The weather should not be foggy or windy. The hot-spray or heated-paint method in which the paint is heated to 50°C or more for application may be used at lower ambient temperatures.

15. The following procedures should be used for the treatment of surfaces:

- a) **New pavement (including resurfaced pavement).** Adequate curing time before painting should be allowed to prevent peeling and blistering. A 30-day curing period is recommended before oil base paints are applied.
 - 1) **Portland cement concrete.** The surface should be cleaned of curing material using sand-blasting or high-pressure water. An acid-etching solution may be needed to counter the leaching of alkali and carbonate salts and to improve adhesion to smooth, glassy aggregate particles. A linseed oil solution may be used to obtain better adhesion.
 - 2) **Asphaltic concrete.** Some combination base paints may be applied 24 hours after placement of bituminous pavement. A primer coat may be used to reduce bleeding of these surfaces especially when curing time is reduced. A primer coat of regular marking paint at approximately 50 per cent of the normal thickness may be applied to new pavement. The markings are then to be repainted soon after the asphalt has

cured. A special primer coat, especially for use in installations with serious asphalt bleeding problems and less bleed-resistance paints, is aluminium paint with a wet paint thickness of approximately 0.5 mm.

- b) **Old pavement (new markings).** Existing markings which are no longer applicable should be removed using the procedures described in paragraphs 20 to 23 and the surfaces cleaned.
- c) **Repainting over existing markings.** The tire marks and rubber deposits should be removed from the existing markings by using trisodium phosphate or other cleaning solutions and scrubbing and rinsing with low-pressure water. Clean these markings of any foreign material which may cause poor adhesion to the existing paint.

Note.— Do not use solutions with more than 1 or 2 per cent soap or detergents because extensive rinsing may be required to remove the soap film.

Equipment for painting

16. Painting equipment should include as a minimum a mechanical marker, surface-cleaning apparatus and auxiliary hand-painting equipment. The mechanical marker should be an atomizing spray-type suitable for the type of paint to be used. It should produce a uniform film thickness of the specified coverage and provide clear-cut edges without running, spattering or overspray. It should properly apply the glass beads if the markings are to be made retro-reflective.

Procedures for application

17. After the pavement has cured adequately and the surfaces are suitably treated and cleaned for the type of paint to be used, outline the markings to be applied.

18. Before the paint is applied, the layouts of marking areas, the condition of the surface, the equipment and materials to be used, and application procedures should be approved by the engineer in charge of the project.

19. A painting procedure similar to the following should be used:

- a) Arrange with air traffic control for safety procedures and communications to protect aircraft, painting crews and equipment, and wet painted surfaces.

- b) Mix the paint in accordance with the manufacturer's instructions.
- c) Apply the paint with the marking machine uniformly at the coverage rate specified without running, spattering or overspraying. A coverage rate of 2.25 to 2.5 square metres per litre to provide a wet paint thickness of approximately 0.4 mm has been found satisfactory.
- d) Ensure that the edges of the markings do not vary from a straight line more than 12 mm in 15 mm and that the tolerance for the dimensions is ± 5 per cent.
- e) If the markings are to be made retro-reflective, apply the glass beads (spheres) uniformly to the wet paint at the specified rate, with mechanical dispensers, at the proper time and pressure for good adhesion. Application rates of 0.7 to 1.2 kg per litre of paint have been found satisfactory.
- f) As soon as the paint has dried enough to accommodate pedestrian traffic, inspect the marked areas for coverage, appearance, uniformity, dimensions and defects. Also check the unmarked areas for spills, splashes or drippings of paint.
- g) If there are uncovered areas, thin spots, discolourations, lack of tolerances or defects in appearance, touch up those areas for suitable uniformity.
- h) Protect the newly painted surfaces until sufficiently dry to accommodate traffic.

REMOVAL OF PAINTED MARKINGS

20. When marking patterns are changed, physical areas or operating procedures are modified, or the thickness of the layers of paint becomes excessive, existing markings may need to be removed. Obscuration of existing markings by painting is not advised except as a temporary measure because the surface layer of paint will wear away or erode and the lower layers will become visible and may be confusing.

Mechanical removal

21. Sandblasting is effective and does little damage to the pavement surface. The sand deposited on the pavement should be removed as the work progresses to prevent

accumulation. High-pressure water or hydroblasting can be used successfully on some markings. Grinding is not recommended because of damage to the pavement surface and probable reduction of friction for braking.

Chemical removal

22. When chemicals are used for paint removal, a large and continuous source of water is usually needed to reduce potential damage to pavement surfaces and to dilute the chemicals washed into drains or channels.

Removal by burning

23. Burning is often used to remove paints; however, methods involving burners using air and butane, propane, or mixtures of liquid petroleum gases have slow burning rates, and the extended periods of exposure to the heat may damage the pavement surface. The overheating melts the asphaltic concrete and causes surface spalling of portland cement concrete. Recently, burners using propane and pure oxygen which produce much hotter flames have been developed. An excess of oxygen rapidly oxidizes the paint and transfers less heat to the underlying pavement surface. With these burners, several layers of paint may be oxidized rapidly with minimal or no damage to the pavement surface. Layers of paint of approximately 0.5 mm can be removed at a single pass. Greater thicknesses of paint may require additional passes with the flame. After the paint is oxidized, the residue should be removed from the pavement surface by wire brushing, hydrobrooming or light sandblasting.

SPECIAL CONSIDERATIONS

Striated markings

24. Striated markings may be used in areas with low temperatures to reduce the effects of frost heaves, especially for wider markings such as threshold markings, runway designation markings, touchdown zone markings and fixed distance markings. Striated markings consist of alternating painted and unpainted stripes, usually of equal widths not exceeding 15 cm, over the specified dimensions of the marking. However, striated markings reduce the conspicuity of the marking when viewed at longer ranges during an approach to the runway because the brightness of the marking becomes the average of the painted and unpainted stripes. Hence striated markings should be used only where necessary.

Outlining markings with black borders

25. White runway markings and yellow taxiway markings may not present a large contrast when applied on light-coloured pavements. The conspicuity of the markings may be improved by painting a black border around the painted markings. Preferably, the border should be a flat black stripe not less than 15 cm wide of a good type of traffic paint. Black borders wider than the minimum will increase the conspicuity of the markings. The black borders may not require repainting as frequently as the markings.

Appendix 4

Procedures for Developing Light Intensities for Day Conditions

1. A pilot landing an aircraft in poor visibility conditions generally needs to see a segment of at least 150 m of the approach and runway lighting pattern. In Category I and II operations, the pilot needs to see this segment at and after the decision height; a similar segment of lighting is required for monitoring purposes at heights below 30 m in Category III operations. One of the procedures used to develop the lighting specified in Annex 14, Volume I, Appendix 2, is described in the following paragraphs.

2. Figure A4-1 illustrates geometrically the 150-m visual segment and the position of this segment as determined by the aircraft flight path at any given height.

3. It is assumed for the purposes of calculation that:

- the glide slope is 3 degrees;
- the pilot's eye is 13 m above and 28 m beyond the main gear (typical dimensions for a large aircraft);

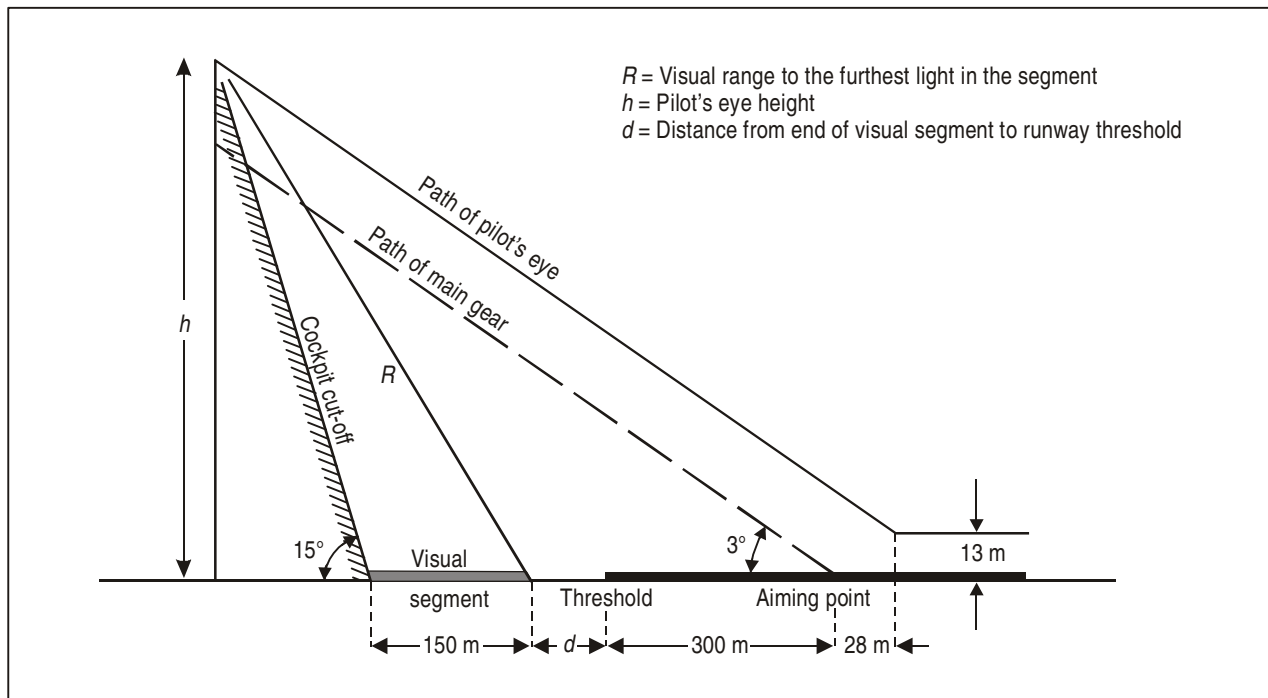

Figure A4-1. Geometry during final approach

- c) the height of the aeroplane is referred to the main gear;
- d) the touchdown aiming point (main gear) is 300 m beyond the threshold;
- e) the cockpit cut-off angle, which defines the near point of the 150-m visual segment, is 15 degrees.

No allowance is made for the decision-making process which would increase the height for each calculation by a height equivalent to 3 seconds decision time prior to the decision height.

4. From Figure A4-1 the required visual range, R , for a 150-m visual segment is:

$$R = \sqrt{h^2 + (150 + h/\tan 15)^2} \quad (1)$$

Also from Figure A4-1 the distance, d , from the furthest part of the visual segment to the runway threshold, can be computed:

$$d = h \left(\frac{1}{\tan 3} - \frac{1}{\tan 15} \right) - \left(\frac{13}{\tan 3} + 300 + 28 + 150 \right) \quad (2)$$

5. In Category I operations, equations (1) and (2) show that at the 60-m decision height only approach lights are visible. As the approach is continued, the value of d decreases to zero. At the height where this occurs, the corresponding value of R is assumed to define the required visual range for the threshold and runway edge lights. For the touchdown zone lights and the runway centre line lights, it is assumed that a segment of 150 m should be visible at touchdown, when $h = 13$ m.

6. For Category II operations, with the decision height set at 30 m, equations (1) and (2) show that the initial visual segment contains both approach and runway lighting. The required visual range is therefore identical for approach, threshold and runway edge lighting. For the landing, the touchdown zone and runway centre line lights should meet the same range requirements as for a Category I landing operation.

7. Category IIIA operations require only the minimum 150-m visual segment to be available from the touchdown zone and runway centre line for the landing and roll-out.

8. Table A4-1 summarizes the visual range requirements derived from equations (1) and (2) for the various categories of operation.

9. Having determined the minimum visual ranges at which various lights in the lighting pattern must be seen in order to provide the required 150-m visual segment (Table A4-1), the next stage of the procedure involves the calculation of the light intensities necessary to meet these requirements.

10. The relationship used is a modified version of Allard's Law:

$$E_{th} = [(I - L_o A) e^{-\sigma R}] R^{-2} \quad (3)$$

where:

E_{th} = the illuminance of the eye at the threshold of detection at a range R

I = the intensity of the light

L_o = the luminance of the background of the light

A = the area of the light source

Table A4-1. Required visual range to meet the minimum operational requirements: 150-m visual segment

Category of operation	Decision height (m)	RVR (m)	Extinction coefficient	Required visual range R (m)		
				Approach	Threshold; runway edge	Touchdown zone; runway centre
I	60	800	0.0063	430	330	200
II	30	400	0.016	310	310	200
IIIA	0	200	0.039	–	–	200

This modification is only necessary if the average luminance of the light, given by I/A , approaches L_o , i.e. in day conditions. At night the basic form of Allard's Law can be used:

$$E_{th} = \frac{I}{R^2} e^{-\sigma R}$$

11. For day conditions an average background luminance, L , of 10 000 cd/m² is assumed.

12. If the luminance factor for the runway surface is 0.35 and assuming that the luminance of the unlit light unit is negligible compared with the value of L_o , then a value of L_o can be derived from the relationship $L_o = 0.35 L$.

13. The appropriate values for A are assumed to be 0.13 m² (0.4 m diameter) for approach lights and 0.018 m² (0.15 m diameter) for all other lights.

14. For day conditions it is assumed that:

$$E_{th} = 2 \times 10^{-7} \times L \text{ lux}$$

Substituting these assumed values in equation (3) leads to the following:

$$I = L (2 \times 10^{-7} \times R^2 e^{\sigma R} + 0.05)$$

for approach lights

$$I = L (2 \times 10^{-7} \times R^2 e^{\sigma R} + 0.006)$$

for runway lights

15. These relations are illustrated in Figure A4-2, assuming that $L = 10\,000 \text{ cd/m}^2$. It is clear that, after an initial sharp rise at low intensities, the visual range is only weakly dependent on intensity. For example, to compensate for a decrease in RVR by a factor of 2, an increase of intensity of more than a factor of 10 may be necessary. On the other hand, uncertainties in intensity due to uncertainties in, for instance, background luminance will not strongly influence the resulting visual range.

16. Table A4-2 summarizes the intensities required to satisfy the requirements of Table A4-1. In Table A4-2 the required visual ranges are in parentheses below the intensities. For the approach lights, the runway edge lights and the runway centre line lights, the symbols A , E and C apply respectively. It is assumed that the intensities of the threshold lights are the same as the runway edge lights and that the touchdown zone lights have the same intensities as the runway centre line lights.

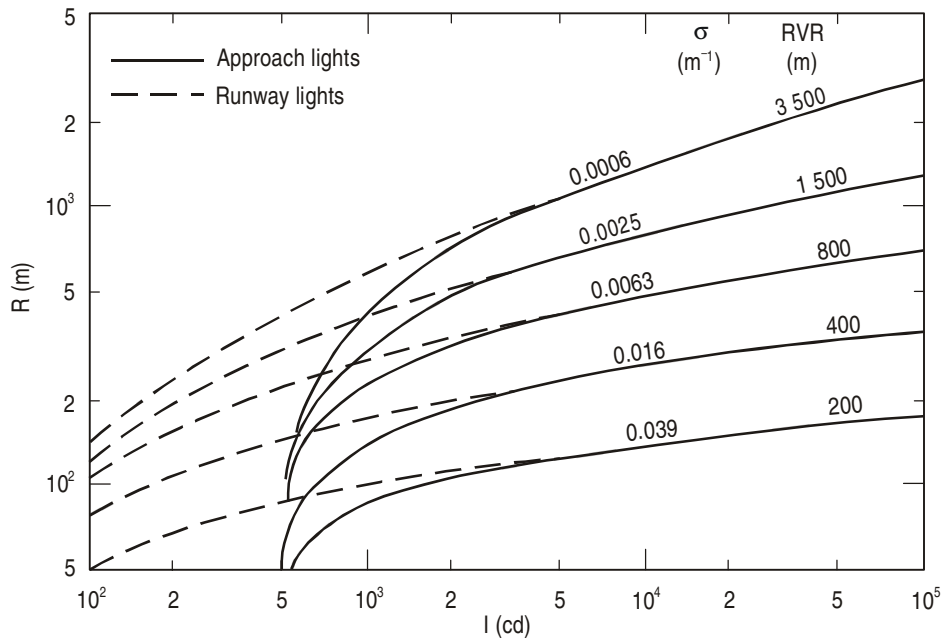

Figure A4-2. Visual range, R , as a function of light intensity, I , for background luminance $L = 10\,000 \text{ cd/m}^2$

17. Comparing Table A4-2 with the minimum average intensities for the lights shown in Annex 14, Volume I, Appendix 2, it can be seen that several intensities in Table A4-2 are unrealistically high. This means that some of the computed RVR-visual segment combinations are impossible to realize in practice.

18. Having developed in Table A4-2 the idealized intensity values to ensure that a 150-m visual segment is visible to the pilot, one further step of calculation is required before the recommended table of intensity values can be defined. This is done in Table A4-3 where the varying effect of background luminances, derived as a function of sun height and cloud condition, is taken into account through so-called luminance multipliers (*LM*). *LM* values are derived in the following way:

- a) At a given meteorological extinction σ and required visual range R , the required intensity I is proportional to the background luminance L . This means that I at any L can be calculated from the I corresponding to $L = 10\,000\text{ cd/m}^2$ by means of the relationship:

$$I(L) = I \times 10^4 \times L \times 10^{-4}$$

- b) In order to incorporate the various values of daytime L in a relatively simple way, the luminance multipliers *LM*, presented in Table A4-3 and to be applied for converting the I values in Table A4-2, are defined as follows:

- *LM* is approximately equal to $L \times 10^{-4}$, within a factor $\sqrt{2}$.
- if $L \times 10^{-4}$ is lower than 0.1 (a relatively rare event during daytime fog), $LM = 0.1$.

19. In Table A4-3 the cloud conditions refer to the clouds above the decision height. If fog extends from ground level to a height above the decision height, then *LM* decreases accordingly.

20. As an approximation, *LM* for “approach with sun” may be used for all directions that have an azimuth angle greater than 60 degrees with the sun’s direction. For smaller angles the use of an *LM* appropriate to an “approach into sun” is recommended.

21. Having computed the *LM* values shown in Table A4-3, it is then possible to finally construct the intensity setting table, bearing in mind that the visual segment should be at least 150 m but that there is little additional benefit if it is greater than 600 m.

22. Table A4-2 shows that many required intensities are higher than the minimum average intensities given in Annex 14, Volume I, Appendix 2, especially if luminance multipliers higher than 1 are applied. This leads to two consequences for Table A4-4. Firstly, maximum intensities (I_{\max}) higher than those in the manual are specified; secondly, if I_{\max} is not sufficient to provide a 150-m visual segment for any specified combination of RVR and *LM* conditions, an RVR_{\min} is estimated, i.e. the lowest RVR for which landing with a 150-m visual segment is possible. This can be done by interpolation in Figure A4-2, taking the required R at visual segment 150 m from Table A4-2, and taking at the abscissa of Figure A4-2 the value I_{\max}/LM in order to correct for the fact that Figure A4-2 gives the I vs. R relation for $L = 10\,000\text{ cd/m}^2$. If I_{\max} of each lighting group is sufficient for a visual segment of 150 m but $\frac{1}{2} I_{\max}$ is not, then I_{\max} is used.

23. If $\frac{1}{2} I_{\max}$ of each lighting group is sufficient for a visual segment of at least 150 m, then the recommended intensity will be not more than $\frac{1}{2} I_{\max}$. This rule is applied because taking $\frac{1}{2} I_{\max}$ instead of I_{\max} will not seriously influence the visual segment, whereas lamp life is lengthened more than tenfold. If an intensity setting lower than $\frac{1}{2} I_{\max}$ provides a visual segment of at least 600 m for all lights, then this lower intensity setting is used.

24. A further criterion is applied to ensure that a balanced lighting system is maintained. To achieve this balance the intensity ratios are as follows:

Approach: Threshold and runway edge = 2:1

Touchdown zone and runway centre line: Threshold and edge = 0.33:1

These ratios are within the limits of Annex 14, Volume I, Appendix 2. Intensities approximating the calculated values are used so that the intensity steps are not smaller than a factor of 2.

25. There are four further rules that are used in constructing the final table of intensity settings:

- a) For each range of RVR values for which an intensity setting is assessed, the basis for each calculation is the RVR (or σ) from Table A4-2 that corresponds with the lowest RVR in the range.
- b) At RVR = 200 m to 399 m, the approach, threshold and runway edge lights have maximum intensities, but this RVR range corresponds with Category IIIA operations where visual guidance from these groups is not required. However, touchdown zone and

Table A4-2. Light intensity required to satisfy the requirements of Table A4-1

RVR (m)	σ (m^{-1})	Intensity (candela)		
		A	E	C
200	.039	–	–	2.0×10^5 (200)
400	.016	28 000 (310)	27 000 (310)	2 000 (200)
800	.0063	6 100 (430)	1 800 (330)	340 (200)
1 500	.0025	1 600 (430)	560 (330)	190 (200)
2 500 ($V_m = 5\ 000$)	.0011	1 100 (430)	370 (330)	160 (200)
5 000 ($V_m = 10\ 000$)	.00030	920 (430)	300 (330)	140 (200)

V_m = meteorological visibility
Visual segment = 150 m

Table A4-3. Luminance multipliers, LM , to be used for assessing the required light intensities at various background luminances during daytime

Sun height ϵ (degree)	Luminance multiplier (LM)			
	Overcast sky		Clear sky	
	Very light (cirrus)	Very dense (dense stratus)	Approach into sun	Approach with sun
5	0.1	0.1	1	0.25
10	0.25	0.1	2	0.5
20	0.5	0.25	4	1
40	2.0	0.5	4	2
60	2.0	0.5	4	4

Table A4-4. Recommended intensity settings, I^* (cd), as a function of meteorological extinction (expressed as RVR) and background luminance (expressed by means of the luminance multiplier, LM , given in Table A4-3)

	Category IIIA	Category II	Category I			
	RVR 200 to 399 m	RVR 400 to 799 m	RVR 800 to 1 499 m	RVR 1 500 to 2 499 m	RVR 2 500 to 4 999 m	RVR > 5 000 m $V_m > 10\ 000$ m
$LM = 0.1$	($RVR_{min} = 220$ m)					
A	30 000	15 000	15 000	3 000	0	0
T, E	15 000	7 500	7 500	1 500	0	0
TD, C	5 000	2 500	2 500	500	0	0
$LM = 0.25$	($RVR_{min} = 250$ m)					
A	30 000	15 000	15 000	6 000	0	0
T, E	15 000	7 500	7 500	3 000	0	0
TD, C	5 000	2 500	2 500	1 000	0	0
$LM = 0.5$	($RVR_{min} = 300$ m)					
A	30 000	30 000	15 000	15 000	0	0
T, E	15 000	15 000	7 500	7 500	0	0
TD, C	5 000	5 000	2 500	2 500	0	0
$LM = 1$	($RVR_{min} = 350$ m)	($RVR_{min} = 450$ m)				
A	30 000	30 000	15 000	15 000	15 000	0
T, E	15 000	15 000	7 500	7 500	7 500	0
TD, C	5 000	5 000	2 500	2 500	2 500	0
$LM = 2$	($RVR_{min} = 400$ m)	($RVR_{min} = 500$ m)				
A	30 000	30 000	15 000	15 000	15 000	0
T, E	15 000	15 000	7 500	7 500	7 500	0
TD, C	5 000	5 000	2 500	2 500	2 500	0
$LM = 4$	($RVR_{min} = 450$ m)	($RVR_{min} = 600$ m)				
A	30 000	30 000	30 000	15 000	15 000	0
T, E	15 000	15 000	15 000	7 500	7 500	0
TD, C	5 000	5 000	5 000	2 500	2 500	0

A = Approach centre line
T = Threshold and wing bar
E = Runway edge
TD = Touchdown zone
C = Runway centre line

If a visual segment of 150 m cannot be reached at maximum intensity, the RVR at which a 150-m visual segment is just visible, RVR_{min} , is given.

NOTES:

1. At $RVR = 2\ 500$ - $4\ 999$, the lights are to be used only for approaches into low sun (i.e. azimuth angle with sun ≤ 60 degrees; sun height ≤ 40 degrees).
2. The recommended intensities are as low as considered acceptable, in the interest of prolonging lamp life and saving energy.
3. If pilots in an approaching aeroplane request a higher intensity setting, use the maximum intensity. In daytime luminances, glare is never a problem.
4. The approach side row lights should preferably have an intensity equal to that recommended for the approach centre line lights. This is technically difficult because of light absorption by the red filter. It is therefore recommended that the approach side row lights have an intensity as high as feasible, in a fixed ratio to the approach centre line lights.
5. The runway end lights should preferably have the same intensities as the runway edge lights. If not technically possible because of flush mounting, they should at least have an intensity equal to the runway centre line lights.

centre line lights will have to be at maximum intensity in order to provide a visual segment of 150 m.

- c) At RVR = 2 500 m to 4 999 m, intensities of all groups can be zero, except for “approach into sun” at sun heights less than 40 degrees (“low sun”). The reason for this is that in these conditions, runway markings have a sufficient visual range. From Table A4-3 it can be seen that approaches into low sun yield *LM* values of 1, 2 or 4.
- d) At RVR ≥ 5 000 m, intensities of all lights can be zero because runway markings are always visible, even for approaches into low sun.

26. On the basis of the foregoing paragraphs, the rules for determining the recommended intensity settings *I** are summarized as follows:

- a) A choice of the intensity settings (cd) in Table A4-5 is made.
- b) At RVR = 200 m to 399 m, $I^* = I_{\max}$ for approach, threshold and runway edge.
- c) At RVR = 2 500 m to 4 999 m, $I^* = 0$ for *LM* = 0.1; 0.25 and 0.5.
- d) At RVR ≥ 5 000 m, $I^* = 0$.
- e) *I** is the nearest possible (within the rules given above) to the *I* values from Table A4-2 at the lowest RVR in the range, at a yet-to-be-selected visual segment between 150 and 600 m, multiplied by the appropriate value of *LM*. These corrected *I* values are denoted below with I_{150} and I_{600} .

- f) Calculate I_{150} for each lighting group:
 - if for any group $I_{150} \geq I_{\max}$, then $I^* = I_{\max}$; calculate the highest RVR_{\min} of all groups;
 - if for all groups $I_{150} \leq I_{\max}$ and if for any group $I_{150} \geq \frac{1}{2} I_{\max}$, then $I^* = I_{\max}$;
 - if for all groups $I_{150} \leq \frac{1}{2} I_{\max}$, then go to g).
- g) Calculate I_{600} for each lighting group:
 - if for any group $I_{600} \geq I_{\max}$, then $I^* = \frac{1}{2} I_{\max}$;
 - if for all groups $I_{600} \leq I_{\max}$, then select the lowest dimming step for which $I^* \geq I_{600}$ for all lights.

27. The procedure described in the preceding paragraphs has several shortcomings, although the lighting designed by this method has adequately supported operations since the calculations were made in the 1960s.

28. The main shortcomings are:

- a) The method assumes that fog is homogeneous. Research has shown that pronounced density profiles exist in most fog. Visibility reduces as height increases. Thus an assumption that fog is homogeneous generally results in an optimistic estimate of the range at which the pilot of an approaching aircraft will see the lights in the approach and runway lighting patterns.
- b) The procedure does not take account of the isocandela characteristics of light fittings. With the

Table A4-5. Intensity settings

	Approach	Threshold; runway edge	Touchdown zone; runway centre line
I_{\max}	30 000	15 000	5 000
	15 000	7 500	2 500
	6 000	3 000	1 000
Dimming steps	3 000	1 500	500
	1 500	750	250

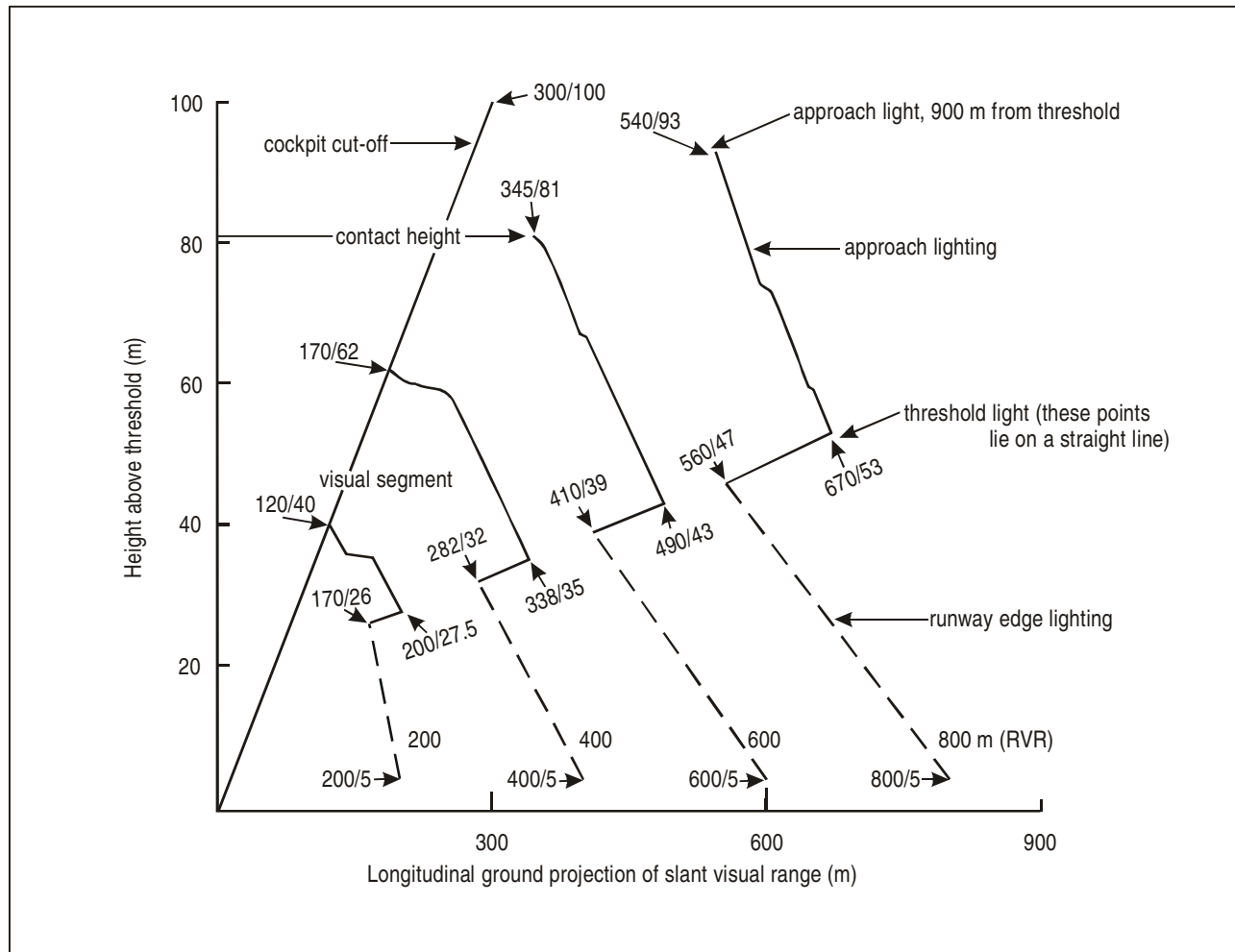

NOTES:

1. Data collected for day fog, with a density representing an occurrence probability of 50 per cent. On 50 per cent of occasions, the conditions will be worse, resulting in lower contact heights and smaller visual segments for the same reported RVR.
2. Glide slope angle = three degrees.
3. Lighting performance and setting angles are in accordance with the requirements of Annex 14, Chapter 5.
4. The discontinuities in the approach lighting curves correspond to those locations where the setting angles of the lights change.
5. Data for the runway centre line lighting are not shown but can be calculated and presented in the same format.

Figure A4-3. An example of calculation of visual segment provided by lighting (moderate fog gradient)

lighting designed by the method described above, the pilot makes use of beam components that are significantly displaced from the central portion of the beam (main beam). Detailed analysis clearly demonstrates that the outermost elements of the lighting beamspreads that were not part of the design calculations play an essential role in the operational use of the lighting guidance. For example, in low visibilities initial contact with the approach lighting is always made at angles that lie outside the main beam.

- c) The calculations do not provide an evaluation of lighting performance at night. One of the main operational uses of the lighting is the support of night landing in all weather conditions.
- d) The method as described assumes a tedious manual calculation to develop the lighting specification. A

method that uses computer-based modelling techniques should be considered for all future design calculations.

29. Validated computer programmes are available that overcome all the shortcomings described above. In these programmes, fog characteristics, lighting specifications and aircraft flight profiles are all modelled to high levels of fidelity.

30. These programmes can be used both to develop and evaluate new lighting designs. By adopting this more modern technique, the lighting designer can produce more efficient systems that fully match the operational requirements.

31. An example of the data that such a programme can provide is shown in Figure A4-3, where the range performance of the lighting in a specified set of circumstances is presented.

Appendix 5

Method Used to Develop the Graphical Presentations in Figures 5-1 to 5-3

1. It is beneficial both to the user and to the designer of airfield lighting if the light control guidance material minimizes the constraints caused by stepped control and the fixed visibility increments shown in Tables 5-1 to 5-3. It is also beneficial to have some means of responding to the large variation in background luminance values, and hence required intensities, covered by the three broad categories of day, twilight and night. Figures 5-1 to 5-3 are a means of achieving this objective.

2. The figures are based on the contents of the tables. Four parallel lines delineate three bands corresponding to day, twilight and night conditions. The uppermost line (bright day) relates to a background luminance (B_L) of 40 000 cd/m^2 and a corresponding eye illumination threshold (E_T) of 10^{-3} lux. The next line (day/twilight boundary) relates to a B_L of 1 000 cd/m^2 and E_T of 10^{-4} lux. The third line (twilight/night boundary) corresponds to a B_L of 15 cd/m^2 and an E_T of 10^{-6} lux, whilst the lowest line relates to a B_L of 0.3 cd/m^2 and an E_T of $10^{-7.5}$ lux (dark night).

3. It will be seen from consideration of the figures that two general relationships govern the data:

- a) All the lines on all the figures have the same slope, such that the required intensity at vis = 10 km is 1/30 of the intensity required at vis = 0 km, i.e.

$$I_{(10)} = \frac{I_{(0)}}{30}$$

Thus for any light, under any known conditions, the lines can be drawn, provided only that the appropriate intensity for zero visibility is known. The

only slight exception to this rule is the maximum daytime case when in low visibility conditions the maximum available intensity specified in Annex 14, Volume I, Appendix 2, is not optimum. Thus, in practice, the maximum daytime boundary line terminates at the point where visibility = 1.5 km, rather than at a visual range of 0 km, but the slope of the line conforms to the general case.

- b) The vertical separation between the lines (width of the day, twilight and night bands on the figures) is constant for all types of lighting, in the ratio of the E_T value covered by that band, i.e.

$$\text{day } E_T = 10^{-3} - 10^{-4} \text{ lux} = 1 \text{ unit}$$

$$\text{twilight } E_T = 10^{-4} - 10^{-6} \text{ lux} = 2 \text{ units}$$

$$\text{night } E_T = 10^{-6} - 10^{-7.5} \text{ lux} = 1.5 \text{ units}$$

therefore:

$$\text{night band} = 1.5 \times \text{width day band}$$

$$\text{twilight band} = 2 \times \text{width day band.}$$

The figures preserve the concept of balanced lighting patterns, e.g. if the visibility is 0 km and the conditions are on the twilight/night boundary, then all three diagrams recommend a 10 per cent intensity setting (on the half-decade scale). Similarly, if the visibility is 4 km, then at the day/twilight boundary, the recommended intensity setting would be 20 per cent (on the 5:1 scale).

Appendix 6

Eye-to-Wheel and Eye-to-Aerial Heights of Aeroplanes

This appendix consists of the following tables:

Table A6-1. Vertical distances between critical points on aircraft at maximum pitch attitude (approach at V_{REF}) (ILS)

Table A6-2. Vertical distances between critical points on aircraft at minimum pitch attitude (approach at $V_{REF} + 20$) (ILS)

Table A6-3. Vertical distances between critical points on aircraft at maximum pitch attitude (approach at V_{REF}) (MLS)

Table A6-4. Vertical distances between critical points on aircraft at minimum pitch attitude (approach at $V_{REF} + 20$) (MLS)

**Table A6-1. Vertical distances between critical points on aircraft
at maximum pitch attitude (approach at V_{REF}) (ILS)**

Aircraft model	2.5-degree glide slope						3.0-degree glide slope					
	Pitch att (deg) Flap setting Gross weight (kg)	Eye path to ILS beam (ft) H2	ILS beam to wheel path (ft) H	Eye path to wheel path (ft) H1	ILS antenna above wheels (ft) H3	Pilot's eye above wheels (ft) H4	Pitch attitude (degrees)	Eye path to ILS beam (ft) H2	ILS beam to wheel path (ft) H	Eye path to wheel path (ft) H1	ILS antenna above wheels (ft) H3	Pilot's eye above wheels (ft) H4
A300-B2, B4	5.3 25 130 000	9.1	22.9	32.0	19.6	28.7	4.9	9.1	22.9	32.0	18.9	28.1
A300-600	5.9 40/30 139 000	9.1	23.4	32.5	20.1	29.2	5.4	9.1	23.4	32.6	19.5	28.6
A310-300	5.5 40/30 118 000	9.1	20.7	29.8	17.9	27.0	5.0	9.1	20.8	29.9	17.4	26.5
A320	5.0 — —	6.0	17.3	23.3	15.0	21.2	5.0	6.0	17.8	23.8	15.0	21.2
B707-320B (NON ADV)	2.6 40 81 648	1.0	20.9	21.9	17.8	18.9	2.1	1.0	20.9	21.9	17.1	18.4
B717-200#	4.0 40 —	5.9	13.7	19.6	10.9	17.2	3.5	5.9	13.7	19.6	10.4	16.7
B727-200	4.3 30 49 216	0.9	22.4	23.2	19.2	20.2	3.8	0.9	22.4	23.2	18.5	19.6
B737-200	4.65 25 34 020	0.8	18.1	18.9	16.1	17.1	4.1	0.8	18.1	18.9	15.7	16.7
B737-200 (ADV)	7.0 15 36 288	0.6	19.9	20.6	18.0	18.9	6.45	0.6	19.9	20.5	17.5	18.4
B737-300#	5.1 30 40 869	0.8	17.7	18.5	15.6	16.6	4.6	0.8	17.7	18.5	15.2	16.2

Aircraft model	2.5-degree glide slope						3.0-degree glide slope					
	Pitch att (deg) Flap setting Gross weight (kg)	Eye path to ILS beam (ft) H2	ILS beam to wheel path (ft) H	Eye path to wheel path (ft) H1	ILS antenna above wheels (ft) H3	Pilot's eye above wheels (ft) H4	Pitch attitude (degrees)	Eye path to ILS beam (ft) H2	ILS beam to wheel path (ft) H	Eye path to wheel path (ft) H1	ILS antenna above wheels (ft) H3	Pilot's eye above wheels (ft) H4
737-400#	4.9 30 42 978	0.8	18.3	19.1	15.9	16.9	4.4	0.8	18.3	19.1	15.5	16.5
B737-500#	5.2 30 39 576	0.8	17.2	18.0	15.3	16.3	4.7	0.8	17.2	18.0	14.9	15.9
B737-600#	5.5 30 —	0.8	17.8	18.6	15.8	16.8	5.0	0.8	17.8	18.6	15.4	16.5
B737-700#	5.5 30 —	0.8	18.4	19.2	16.3	17.2	5.0	0.8	18.4	19.2	15.8	16.8
B737-800#	3.9 30 —	0.9	18.2	19.1	15.5	16.6	3.4	0.9	18.2	19.1	15.0	16.2
B737-900#	3.0 30	1.0	17.7	18.7	14.9	16.0	2.5	1.0	17.7	18.7	14.3	15.5
B747-100/200 (WING GEAR)	5.05 25 170 100	20.4	24.1	44.6	20.6	40.9	4.6	20.4	24.2	44.7	19.9	40.2
B747-100/200 (BODY GEAR)	5.05 25 170 100	20.4	24.1	44.5	20.0	40.3	4.6	20.4	24.2	44.6	19.3	39.6
B747-300*# (WING GEAR)	5.5 25 190 512	20.9	24.4	45.3	20.8	41.6	5.0	21.0	24.4	45.3	20.1	40.9
B747-400#	5.0 25 181 437	21.0	23.4	44.4	19.4	40.3	4.5	21.0	23.4	44.4	18.6	39.4
B757-200#	5.9 25 72 466	6.1	22.5	28.6	19.6	25.5	5.4	6.1	22.5	28.6	18.5	24.9
B757-300#	4.2 25 80 739	6.2	21.8	28.0	17.9	24.3	3.7	6.2	21.8	28.0	17.1	23.2

Aircraft model	2.5-degree glide slope						3.0-degree glide slope					
	Pitch att (deg) Flap setting Gross weight (kg)	Eye path to ILS beam (ft) H2	ILS beam to wheel path (ft) H	Eye path to wheel path (ft) H1	ILS antenna above wheels (ft) H3	Pilot's eye above wheels (ft) H4	Pitch attitude (degrees)	Eye path to ILS beam (ft) H2	ILS beam to wheel path (ft) H	Eye path to wheel path (ft) H1	ILS antenna above wheels (ft) H3	Pilot's eye above wheels (ft) H4
B767-200 B767-200ER	5.25 25 102 786	6.6	23.5	30.2	20.4	27.2	4.75	6.6	23.5	30.2	19.7	26.6
B767-300	4.6 25 107 503	6.7	24.0	30.7	20.3	27.2	4.1	6.7	24.0	30.7	19.6	26.5
B767-300ER#	3.9 30 109 769	6.8	22.9	29.7	19.3	26.3	3.5	6.8	23.1	29.9	18.7	25.7
B767-400ER#	3.95 25 -	6.8	25.2	32.0	21.1	28.1	3.45	6.8	25.2	32.0	23.0	27.3
B777-200#	3.8 25 -	12.9	22.6	35.5	18.5	31.1	3.3	12.9	22.6	35.5	17.7	30.2
B777-300#	3.6 25 -	12.9	24.1	37.0	19.3	31.9	3.2	12.9	24.3	37.2	18.5	31.0
DC-8-71#	2.6 25 -	6.6	18.1	24.7	14.1	21.0	2.1	6.6	18.1	24.7	13.3	20.3
DC-8-72#	2.5 25 -	6.6	16.5	23.1	13.2	20.1	2.0	6.6	16.5	23.1	12.6	19.5
DC-8-73#	1.6 35 -	6.7	16.5	23.2	12.5	19.5	1.1	6.7	16.5	23.2	11.7	18.8
DC-9-10#	3.6 20 -	6.0	11.5	17.4	9.3	15.6	3.1	6.0	11.5	17.4	15.3	38.5
DC-9-20#	7.5 25 -	5.4	14.7	20.1	12.6	18.4	7.0	5.4	14.7	20.1	12.2	18.1

Aircraft model	2.5-degree glide slope						3.0-degree glide slope					
	Pitch att (deg) Flap setting Gross weight (kg)	Eye path to ILS beam (ft) H2	ILS beam to wheel path (ft) H	Eye path to wheel path (ft) H1	ILS antenna above wheels (ft) H3	Pilot's eye above wheels (ft) H4	Pitch attitude (degrees)	Eye path to ILS beam (ft) H2	ILS beam to wheel path (ft) H	Eye path to wheel path (ft) H1	ILS antenna above wheels (ft) H3	Pilot's eye above wheels (ft) H4
DC-9-30#	7.4 25 —	5.5	16.3	21.7	13.8	19.6	6.9	5.5	16.3	21.7	13.3	19.1
DC-9-33#	6.2 25 46 267	5.6	15.3	20.9	12.8	18.7	5.7	5.6	15.3	20.9	12.3	18.3
DC-9-40#	6.4 25 —	5.6	16.0	21.6	13.4	19.3	5.9	5.6	16.0	21.6	12.9	18.9
DC-9-50#	7.2 25 —	5.5	17.6	23.1	14.8	20.6	6.7	5.5	17.7	23.1	14.3	20.2
DC-10-30#	6.7 35 —	20.3	17.2	37.5	14.0	33.5	6.2	20.3	17.2	37.5	13.3	32.6
DC-10-40#	7.5 35 —	20.5	18.3	38.8	15.0	34.7	7.0	20.5	18.3	38.8	14.4	33.9
Fokker 50	0.4 26.5 15 075	1.9	9.8	11.7	8.3	10.5	0.0	1.8	9.9	11.8	8.0	10.3
Fokker 100	4.5 25 36 000	2.7	16.4	19.1	14.0	16.9	4.0	2.7	16.4	19.1	13.5	16.5
IL-76TD	2.5 30 155 000	6.7	17.1	23.8	14.0	21.1	2.0	6.7	17.1	23.8	13.3	20.5
IL-76TD	-1.5 43 155 000	7.3	12.1	19.4	8.9	16.6	-2.0	7.3	12.1	19.4	8.3	16.1
IL-76TF	2.5 30 155 000	6.7	18.0	24.7	14.4	21.5	2.0	6.7	18.0	24.7	13.7	20.9

Aircraft model	2.5-degree glide slope						3.0-degree glide slope					
	Pitch att (deg) Flap setting Gross weight (kg)	Eye path to ILS beam (ft) H2	ILS beam to wheel path (ft) H	Eye path to wheel path (ft) H1	ILS antenna above wheels (ft) H3	Pilot's eye above wheels (ft) H4	Pitch attitude (degrees)	Eye path to ILS beam (ft) H2	ILS beam to wheel path (ft) H	Eye path to wheel path (ft) H1	ILS antenna above wheels (ft) H3	Pilot's eye above wheels (ft) H4
IL-76TF	-1.5 43 155 000	7.3	12.3	19.6	8.7	16.4	-2.0	7.3	12.3	19.6	7.9	15.7
IL-86	2.7 40 175 000	6.4	22.8	29.2	18.6	25.2	2.2	6.4	22.8	29.2	17.7	24.4
IL-96-300	1.9 49 175 000	6.5	21.2	27.7	17.3	24.0	1.4	6.5	22.2	27.7	16.5	23.2
IL-96-400T	2.1 40 175 000	6.5	23.1	29.6	18.4	25.0	1.6	6.5	23.1	29.6	17.4	24.1
IL-114	0.3 20 23 500	5.9	8.5	14.4	6.9	12.9	-0.2	5.9	8.5	14.4	6.6	12.6
MD-80/81/ 82/83/88#	6.9 28 -	5.5	20.1	25.6	16.8	22.7	6.4	5.5	20.1	25.6	16.1	22.1
MD-87#	7.0 28 -	5.5	18.7	24.2	15.8	21.6	6.5	5.5	18.7	24.2	15.2	21.1
MD-90#	6.1 28	5.6	19.8	25.4	16.2	22.2	5.6	5.6	19.8	25.4	15.5	21.6
MD-11#	6.1 35	20.1	17.9	38.0	14.3	33.5	5.6	20.1	17.9	38.0	13.5	32.6

$V_{ref} + 5$ is used. $V_{ref} + 20$ would only be flown in a non-normal condition.

* Wing gear is lowest part of aeroplane until pitch attitude exceeds 8 degrees.

Table A6-2. Vertical distances between critical points on aircraft at minimum pitch attitude (approach at $V_{REF} + 20$) (ILS)

Aircraft model	2.5-degree glide slope						3.0-degree glide slope					
	Pitch att (deg) Flap setting Gross weight (kg)	Eye path to ILS beam (ft) H2	ILS beam to wheel path (ft) H	Eye path to wheel path (ft) H1	ILS antenna above wheels (ft) H3	Pilot's eye above wheels (ft) H4	Pitch attitude (degrees)	Eye path to ILS beam (ft) H2	ILS beam to wheel path (ft) H	Eye path to wheel path (ft) H1	ILS antenna above wheels (ft) H3	Pilot's eye above wheels (ft) H4
A300-B2, B4	1.4 25 130 000	9.2	17.7	26.9	14.4	23.5	0.9	9.2	17.8	26.9	13.7	22.9
A300-600	1.9 40/30 139 000	9.2	18.1	27.3	14.8	23.9	1.4	9.2	18.2	27.3	14.1	23.3
A310-300	1.2 40/30 118 000	9.2	15.9	25.1	13.0	22.2	0.8	9.2	16.0	25.1	12.5	21.7
A320	2.0 — —	6.3	14.5	20.8	12.1	18.7	2.0	6.3	15.0	21.3	12.1	18.6
B707-320B (NON ADV)	-1.7 50 69 401	1.3	15.5	16.8	12.3	13.8	-2.2	1.3	15.5	16.8	11.7	13.2
B717-200#	1.8 40	6.2	11.3	17.5	8.5	15.1	1.3	6.2	11.3	17.5	8.0	14.6
B727-200	-2.0 40 48 989	1.3	14.3	15.6	11.0	12.5	-2.5	1.4	14.3	15.6	10.3	11.9
B737-200	-2.5 40 34 020	1.4	12.4	13.8	10.3	11.9	-3.0	1.4	12.4	13.8	9.9	11.5
B737-200 (ADV)	-1.0 40 34 020	1.3	13.6	14.9	11.6	13.0	-1.5	1.3	13.6	14.9	11.2	12.6
B737-300#	2.1 40 51 710	1.0	15.2	16.2	13.0	14.3	1.6	1.0	15.2	16.2	12.6	13.9
B737-400#	2.0 40 54 885	1.0	15.6	16.6	13.1	14.4	1.5	1.0	15.6	16.6	12.6	13.9

Aircraft model	2.5-degree glide slope						3.0-degree glide slope					
	Pitch att (deg) Flap setting Gross weight (kg)	Eye path to ILS beam (ft) H2	ILS beam to wheel path (ft) H	Eye path to wheel path (ft) H1	ILS antenna above wheels (ft) H3	Pilot's eye above wheels (ft) H4	Pitch attitude (degrees)	Eye path to ILS beam (ft) H2	ILS beam to wheel path (ft) H	Eye path to wheel path (ft) H1	ILS antenna above wheels (ft) H3	Pilot's eye above wheels (ft) H4
B737-500#	2.3 40 49 985	1.0	15.0	16.0	13.0	14.2	1.8	1.0	15.0	16.0	12.6	13.9
B737-600#	2.6 40	1.0	15.5	16.5	13.5	14.7	2.1	1.0	15.5	16.5	13.1	14.4
B737-700#	2.6 40	1.0	15.9	16.9	13.7	14.9	2.1	1.0	15.9	16.9	13.3	14.5
B737-800#	1.8 40	1.1	16.0	17.1	13.4	14.6	1.3	1.1	16.0	17.1	12.8	14.1
B737-900#	1.4 40	1.1	15.9	17.0	13.1	14.3	0.9	1.1	15.9	17.0	12.5	13.8
B747-100/200 (WING GEAR)	-0.75 30 170 100	20.2	15.8	36.0	12.1	32.1	-1.25	20.2	15.8	36.0	11.4	31.4
B747-100/200 (BODY GEAR)	-0.75 30 170 100	20.2	14.6	34.8	10.5	30.5	-1.25	20.2	14.6	34.8	9.6	29.6
B747-300 * (WING GEAR)	0.5 30 255 830	20.8	17.2	38.0	13.5	34.2	0.0	20.8	17.2	38.0	12.8	33.4
B747-400#	2.5 30 294 835	20.9	19.4	40.3	15.3	36.1	2.0	20.9	19.4	40.3	14.5	35.2
B757-200#	2.5 30 89 811	6.4	18.0	24.4	14.6	21.2	2.0	6.4	18.0	24.4	14.0	20.6
B757-300#	2.2 30 101 605	6.4	18.7	25.1	14.7	21.3	1.7	6.4	18.7	25.1	14.0	20.6
B767-200	0.2 30 123 379	7.1	16.6	23.7	13.3	20.6	-0.7	7.1	16.6	23.7	12.7	20.0

Aircraft model	2.5-degree glide slope						3.0-degree glide slope					
	Pitch att (deg) Flap setting Gross weight (kg)	Eye path to ILS beam (ft) H2	ILS beam to wheel path (ft) H	Eye path to wheel path (ft) H1	ILS antenna above wheels (ft) H3	Pilot's eye above wheels (ft) H4	Pitch attitude (degrees)	Eye path to ILS beam (ft) H2	ILS beam to wheel path (ft) H	Eye path to wheel path (ft) H1	ILS antenna above wheels (ft) H3	Pilot's eye above wheels (ft) H4
B767-200ER	0.2 30 129 276	7.1	16.6	23.7	13.3	20.6	-0.7	7.1	16.6	23.7	12.7	20.0
B767-300	0.2 30 136 080	7.1	17.6	24.6	13.9	21.1	-0.3	7.1	17.6	24.7	13.2	20.4
B767-300ER#	2.5 25 109 769	6.9	20.9	27.8	17.3	24.3	2.0	6.9	20.9	27.8	16.5	23.6
B767-400ER#	2.75 30 -	6.9	23.2	30.1	19.1	26.2	2.25	6.9	23.3	30.2	18.3	25.4
B777-200#	2.3 30 -	12.7	20.1	32.9	16.0	26.2	1.9	12.8	20.3	33.1	15.4	27.8
B777-300#	1.9 30 -	12.7	20.8	33.5	15.9	28.4	1.4	12.7	20.8	33.5	15.0	27.3
DC-8-61/71#	2.5 50 -	7.2	9.9	17.1	5.9	13.4	-3.0	7.2	9.9	17.1	5.0	12.6
DC-8-72#	0.5 50 -	6.8	13.9	20.7	10.6	17.7	0.0	6.8	13.9	20.7	9.9	17.1
DC-8-73#	-0.3 50 -	6.9	13.5	20.4	9.4	16.7	-0.8	7.0	13.5	20.4	8.6	15.9
DC-9-10#	-2.7 50 -	6.8	6.1	12.9	4.0	11.1	-3.2	6.8	6.1	12.9	3.5	10.7
DC-9-20#	2.8 50 -	6.8	10.8	16.9	8.7	15.1	2.3	6.1	10.8	16.9	8.2	14.7

Aircraft model	2.5-degree glide slope						3.0-degree glide slope					
	Pitch att (deg) Flap setting Gross weight (kg)	Eye path to ILS beam (ft) H2	ILS beam to wheel path (ft) H	Eye path to wheel path (ft) H1	ILS antenna above wheels (ft) H3	Pilot's eye above wheels (ft) H4	Pitch attitude (degrees)	Eye path to ILS beam (ft) H2	ILS beam to wheel path (ft) H	Eye path to wheel path (ft) H1	ILS antenna above wheels (ft) H3	Pilot's eye above wheels (ft) H4
DC-9-30#	2.4 50 -	6.1	11.3	17.4	8.7	15.2	1.9	6.1	11.3	17.4	8.2	
DC-9-33 #	1.4 50 -	6.3	10.5	16.8	8.0	14.5	0.9	6.3	10.5	16.8	7.4	14.1
DC-9-40#	1.1 50 -	6.3	10.4	16.8	7.8	14.5	0.6	6.3	10.4	16.8	7.2	13.9
DC-9-50#	2.7 50 -	6.1	12.6	18.7	9.7	16.1	2.2	6.1	12.6	18.7	9.1	15.6
DC-10-30#	3.6 50 -	19.3	13.2	32.5	9.9	28.4	3.1	19.3	13.2	32.5	9.3	27.6
DC-10-40#	4.0 50 -	19.4	13.7	33.2	10.5	29.0	3.5	19.4	13.7	33.2	9.8	28.2
Fokker 50	-6.1 35 14 200	2.8	5.7	8.5	4.1	7.3	-6.5	2.8	5.8	8.6	3.9	7.1
Fokker 100	-2.5 42 29 000	3.4	9.6	13.0	7.2	10.8	-3.0	3.4	9.6	13.0	6.7	10.4
IL-76TD	0.5 30 155 000	7.0	14.6	21.6	11.5	18.9	0	7.0	14.6	21.6	10.8	21.6
IL-76TD	-3.5 43 155 000	7.6	9.6	17.2	6.4	14.4	-4.0	7.6	9.6	17.2	5.8	13.8
IL-76TF	0.5 30 155 000	7.0	15.2	22.2	11.5	19.0	0	7.0	15.2	22.2	10.8	22.2

Aircraft model	2.5-degree glide slope						3.0-degree glide slope					
	Pitch att (deg) Flap setting Gross weight (kg)	Eye path to ILS beam (ft) H2	ILS beam to wheel path (ft) H	Eye path to wheel path (ft) H1	ILS antenna above wheels (ft) H3	Pilot's eye above wheels (ft) H4	Pitch attitude (degrees)	Eye path to ILS beam (ft) H2	ILS beam to wheel path (ft) H	Eye path to wheel path (ft) H1	ILS antenna above wheels (ft) H3	Pilot's eye above wheels (ft) H4
IL-76TF	-3.5 43 155 000	7.6	9.4	17.0	5.7	13.7	-4.0	7.6	9.4	17.0	5.0	13.1
IL-86	1.7 40 175 000	6.5	21.1	27.6	16.9	23.5	1.2	6.5	21.1	27.6	16.0	22.7
IL-96-300	0.1 40 175 000	6.6	18.4	25.0	14.5	21.3	-0.4	6.6	18.4	25.0	13.7	20.5
IL-96-400T	0.4 40 220 000	6.6	19.9	26.5	15.1	21.9	-0.1	6.6	19.9	26.5	14.1	20.9
IL-114	-1.1 20 23 500	6.0	7.6	13.6	6.0	12.1	-1.6	6.0	7.6	13.6	5.6	11.8
MD-80/81 82/83/88#	2.6 40 -	6.1	14.4	20.5	11.0	17.5	2.1	6.1	14.4	20.5	10.4	16.9
MD-87#	2.9 40 -	6.1	13.9	20.0	11.0	17.4	2.4	6.1	13.9	20.0	10.4	16.8
MD-90#	2.2 40	6.2	14.3	20.4	10.7	17.2	1.7	6.2	14.3	20.4	10.0	16.5
MD-11#	2.2 50 -	18.8	12.2	31.1	8.6	26.6	1.7	18.8	12.3	31.1	7.9	25.7

$V_{ref} + 5$ is used. $V_{ref} + 20$ would only be flown in a non-normal condition.

* Wing gear is lowest part of aeroplane until pitch attitude exceeds 8 degrees.

Table A6-3. Vertical distances between critical points on aircraft at maximum pitch attitude (approach at V_{REF}) (MLS)

Aircraft model	2.5-degree glide slope						3.0-degree glide slope					
	Pitch att (deg) Flap setting Gross weight (kg)	Eye path to ILS beam (ft) H2	ILS beam to wheel path (ft) H	Eye path to wheel path (ft) H1	ILS antenna above wheels (ft) H3	Pilot's eye above wheels (ft) H4	Pitch attitude (degrees)	Eye path to ILS beam (ft) H2	ILS beam to wheel path (ft) H	Eye path to wheel path (ft) H1	ILS antenna above wheels (ft) H3	Pilot's eye above wheels (ft) H4
A320	5 — —	7.2	16.2	23.3	13.8	21.2	5.0	7.2	16.6	23.8	13.8	21.2
B737-300#	5.1 30 —	11.4	7.2	18.6	6.1	16.6	4.6	11.4	7.2	18.6	5.8	16.2
B737-400#	4.9 30 —	11.3	7.8	19.1	6.5	17.0	4.4	11.3	7.8	19.1	6.2	16.5
B737-500#	5.2 30 —	11.4	6.6	18.0	5.7	16.3	4.7	11.4	6.6	18.0	5.5	15.9
B737-600#	5.5 30 —	11.5	8.0	19.5	6.7	17.4	5.0	11.5	8.0	19.5	6.4	16.9
B737-700#	5.5 30 —	11.5	7.4	18.9	6.3	17.0	5.0	11.5	7.4	18.9	6.1	16.6
B737-800#	3.9 30 —	11.0	8.1	19.1	6.5	16.6	3.4	11.0	8.1	19.1	6.2	16.2
B737-900#	3.0 30 —	10.7	8.0	18.7	6.2	16.0	2.5	10.7	8.0	18.7	5.8	15.5
B747-400#	5 25 —	20.6	23.8	44.4	19.8	40.3	4.5	20.6	23.8	44.4	19.0	39.4
B757-200#	5.9 25 —	7.0	21.6	28.6	18.4	25.5	5.4	7.0	21.6	28.6	17.7	24.9

Aircraft model	2.5-degree glide slope						3.0-degree glide slope					
	Pitch att (deg) Flap setting Gross weight (kg)	Eye path to ILS beam (ft) H2	ILS beam to wheel path (ft) H	Eye path to wheel path (ft) H1	ILS antenna above wheels (ft) H3	Pilot's eye above wheels (ft) H4	Pitch attitude (degrees)	Eye path to ILS beam (ft) H2	ILS beam to wheel path (ft) H	Eye path to wheel path (ft) H1	ILS antenna above wheels (ft) H3	Pilot's eye above wheels (ft) H4
B757-300#	4.2 25 -	7.1	21.0	28.1	17.1	24.3	3.7	7.1	21.0	28.1	16.4	23.6
Fokker 100	4.5 25 36 000	-2.4	21.5	19.1	19.5	16.9	4.0	-2.4	21.6	19.1	19.1	16.5
B767-300ER#	3.9 30 -	6.6	23.1	29.7	19.5	26.3	3.5	6.6	23.1	29.7	18.9	25.7
B767-400ER#	3.95 25 -	6.6	23.0	29.6	19.8	26.5	3.45	6.6	23.0	29.6	19.2	25.9
B777-200#	3.8 25 -	9.9	25.6	35.5	21.5	31.1	3.3	9.9	25.6	35.5	20.6	30.2
B777-300#	3.6 25 -	9.9	27.1	37.0	22.2	31.9	3.2	9.9	27.3	37.2	21.4	31.0
DC-10-30#	6.7 35 -	20.3	17.3	37.6	14.0	33.5	6.2	20.3	17.3	37.6	13.4	32.7
DC-10-40#	7.5 35 -	20.5	18.3	38.8	15.1	34.8	7.0	20.5	18.3	38.8	14.4	34.0
MD-11#	6.1 35 -	20.1	17.9	38.0	14.3	33.6	5.6	20.1	17.9	38.0	13.6	32.7

$V_{ref} + 5$ is used. $V_{ref} + 20$ would only be flown in a non-normal condition.

**Table A6-4. Vertical distances between critical points on aircraft
at minimum pitch attitude (approach at $V_{REF} + 20$) (MLS)**

Aircraft model	2.5-degree glide slope						3.0-degree glide slope					
	Pitch att (deg) Flap setting Gross weight (kg)	Eye path to ILS beam (ft) H2	ILS beam to wheel path (ft) H	Eye path to wheel path (ft) H1	ILS antenna above wheels (ft) H3	Pilot's eye above wheels (ft) H4	Pitch attitude (degrees)	Eye path to ILS beam (ft) H2	ILS beam to wheel path (ft) H	Eye path to wheel path (ft) H1	ILS antenna above wheels (ft) H3	Pilot's eye above wheels (ft) H4
A320	2 — —	7.5	13.4	20.8	11.0	18.7	2.0	7.4	13.9	21.3	11.0	18.6
B737-300#	2.1 40 —	10.4	5.8	16.2	4.7	14.3	1.6	10.4	5.8	16.2	4.5	13.9
B737-400#	2.0 40 —	10.4	6.2	16.6	4.9	14.4	1.5	10.4	6.2	16.6	4.6	13.9
B737-500#	2.3 40 —	10.5	5.6	16.1	4.6	14.2	1.8	10.5	5.6	16.1	4.5	13.9
B737-600#	2.6 40 —	10.6	6.5	17.1	5.2	14.9	2.1	10.6	6.5	17.1	4.9	14.4
B737-700#	2.6 40 —	10.6	6.1	16.7	5.0	14.7	2.1	10.6	6.1	16.7	4.8	14.3
B737-800#	1.8 40 —	10.3	6.8	17.1	5.2	14.6	1.3	10.3	6.8	17.1	4.9	14.1
B737-900#	1.4 40 —	10.2	6.9	17.1	5.1	14.3	0.9	10.2	6.9	17.1	4.7	13.8
B747-400#	2.5 30 —	20.5	19.8	40.3	15.7	36.1	2.0	7.2	17.2	24.4	13.3	20.6
B757-200#	2.5 30 —	7.2	17.2	24.4	13.9	21.2	2.0	7.2	17.2	24.4	13.3	20.6

Aircraft model	2.5-degree glide slope						3.0-degree glide slope					
	Pitch att (deg) Flap setting Gross weight (kg)	Eye path to ILS beam (ft) H2	ILS beam to wheel path (ft) H	Eye path to wheel path (ft) H1	ILS antenna above wheels (ft) H3	Pilot's eye above wheels (ft) H4	Pitch attitude (degrees)	Eye path to ILS beam (ft) H2	ILS beam to wheel path (ft) H	Eye path to wheel path (ft) H1	ILS antenna above wheels (ft) H3	Pilot's eye above wheels (ft) H4
B757-300#	2.2 30 -	7.2	17.9	25.1	14.0	21.3	1.7	7.2	17.9	25.1	13.3	20.6
B767-300ER#	2.5 25 -	6.7	21.1	27.8	17.5	24.3	2.0	6.7	21.1	27.8	16.8	23.6
B767-400ER#	2.75 30 -	6.6	23.3	29.9	19.2	26.0	2.25	6.7	23.3	30.0	18.4	25.2
B777-200#	2.3 30 -	9.8	23.1	32.9	19.0	28.5	1.9	9.8	23.3	33.1	18.3	27.8
B777-300#	1.9 30	9.7	23.8	33.5	18.9	28.4	1.4	9.7	23.8	33.5	17.9	27.3
DC-10-30#	3.6 50	19.3	13.3	32.6	10.0	28.4	3.1	19.3	13.3	32.6	9.3	27.6
DC-10-40#	4.0 50	19.4	13.8	33.2	10.5	29.1	3.5	19.4	13.8	33.2	9.9	28.3
MD-11#	2.2 50	18.8	12.3	31.1	8.6	26.6	1.7	18.8	12.3	31.1	7.9	25.7
Fokker 100	-2.5 42 29 000	-2.8	15.8	13.0	13.7	10.8	-3.0	-2.8	15.8	13.0	13.3	10.4

$V_{ref} + 5$ is used. $V_{ref} + 20$ would only be flown in a non-normal condition.

ICAO TECHNICAL PUBLICATIONS

The following summary gives the status, and also describes in general terms the contents of the various series of technical publications issued by the International Civil Aviation Organization. It does not include specialized publications that do not fall specifically within one of the series, such as the Aeronautical Chart Catalogue or the Meteorological Tables for International Air Navigation.

International Standards and Recommended Practices are adopted by the Council in accordance with Articles 54, 37 and 90 of the Convention on International Civil Aviation and are designated, for convenience, as Annexes to the Convention. The uniform application by Contracting States of the specifications contained in the International Standards is recognized as necessary for the safety or regularity of international air navigation while the uniform application of the specifications in the Recommended Practices is regarded as desirable in the interest of safety, regularity or efficiency of international air navigation. Knowledge of any differences between the national regulations or practices of a State and those established by an International Standard is essential to the safety or regularity of international air navigation. In the event of non-compliance with an International Standard, a State has, in fact, an obligation, under Article 38 of the Convention, to notify the Council of any differences. Knowledge of differences from Recommended Practices may also be important for the safety of air navigation and, although the Convention does not impose any obligation with regard thereto, the Council has invited Contracting States to notify such differences in addition to those relating to International Standards.

Procedures for Air Navigation Services (PANS) are approved by the Council for worldwide application. They contain, for the most part, operating procedures regarded as not yet having attained a sufficient degree of

maturity for adoption as International Standards and Recommended Practices, as well as material of a more permanent character which is considered too detailed for incorporation in an Annex, or is susceptible to frequent amendment, for which the processes of the Convention would be too cumbersome.

Regional Supplementary Procedures (SUPPS) have a status similar to that of PANS in that they are approved by the Council, but only for application in the respective regions. They are prepared in consolidated form, since certain of the procedures apply to overlapping regions or are common to two or more regions.

The following publications are prepared by authority of the Secretary General in accordance with the principles and policies approved by the Council.

Technical Manuals provide guidance and information in amplification of the International Standards, Recommended Practices and PANS, the implementation of which they are designed to facilitate.

Air Navigation Plans detail requirements for facilities and services for international air navigation in the respective ICAO Air Navigation Regions. They are prepared on the authority of the Secretary General on the basis of recommendations of regional air navigation meetings and of the Council action thereon. The plans are amended periodically to reflect changes in requirements and in the status of implementation of the recommended facilities and services.

ICAO Circulars make available specialized information of interest to Contracting States. This includes studies on technical subjects.

© ICAO 2004
01/04, E/P1/1850; 12/05, E/P2/400

Order No. 9157P4
Printed in ICAO

